

Handout 8

Altering a Pattern

Directions: Follow these guidelines for successful pattern alterations:

- Adjustments for length and width must be made on both front and back pattern pieces.
- A width adjustment of 2 in. or less can be made along the side seams of a garment.
- Check to make sure the grain line remains straight.
- Redraw any design details or darts that are changed by the pattern alteration.

The following illustrations and directions explain some common pattern adjustments.

Lengthening a Pattern

1. Cut the pattern apart on the adjustment lines.
2. Tape tissue paper to one part of the pattern piece.
3. Using a measuring stick, extend the grain line by drawing one continuous straight line through the tissue paper.
4. Measure down the amount needed for length. Tape the second piece of the pattern to the tissue paper at that point, making sure the grain lines match up.
5. Connect the cutting lines. See **Figure 8-1**.
6. Use the same method to adjust the back pattern piece.

Shortening a Pattern

1. Measure the amount to be shortened upward from the adjustment line on the front pattern piece.
2. At that point, draw a second line that is parallel to the adjustment line.
3. Fold the pattern along the adjustment line and bring it down so that the adjustment line now lies directly over the line you drew in Step 2. Match the grain line markings. Tape the fold in place. See **Figure 8-2**.
4. Use the same method to adjust the back pattern piece.

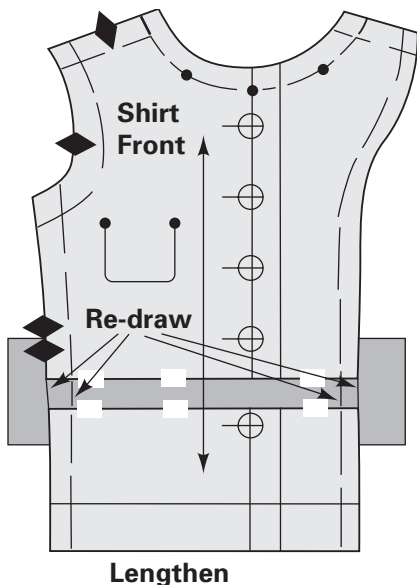

Fig. 8-1

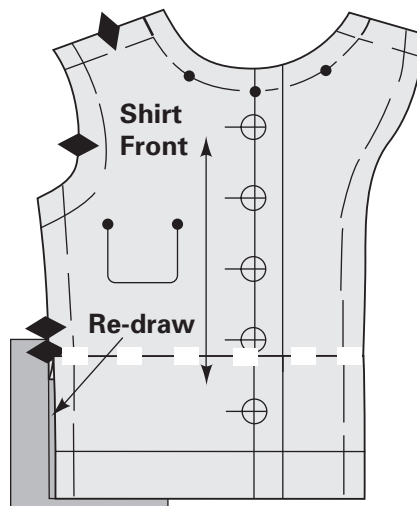

Fig. 8-2

(Continued on next page)

Altering a Pattern (continued)**Increasing Pattern Width**

1. Tape tissue paper along the pattern piece edge.
2. Divide the total adjustment needed by the number of seam allowances. If a garment has two side seams and four seam allowances, the amount to be adjusted on each piece is one-fourth of the total.
3. Measure the amount needed outward from the cutting lines. For example, to increase the waistline by 1 in., add $\frac{1}{4}$ in. to the side seam of the front pattern piece and $\frac{1}{4}$ in. to the side seam of the back pattern piece. Both side seams will be increased by $\frac{1}{2}$ in. and the total garment will be increased by 1 in. See **Figure 8-3**.
4. Carefully redraw the cutting lines and seam lines to blend in with areas of the pattern that did not need adjustment.

Decreasing Pattern Width

1. Divide the total amount of adjustment needed by the number of seam allowances.
 2. Measure the amount needed inward from the cutting lines.
 3. Redraw the cutting lines and seam lines to blend in with the areas that did not need to be decreased.
- See **Figure 8-4**.

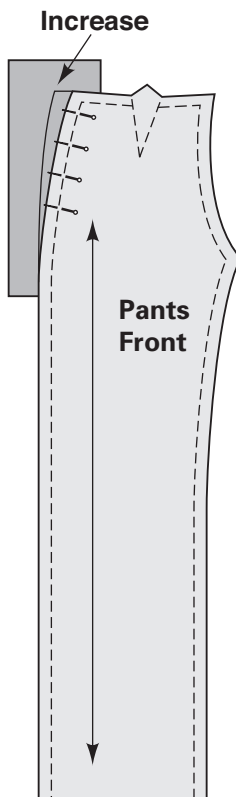

Fig. 8-3.

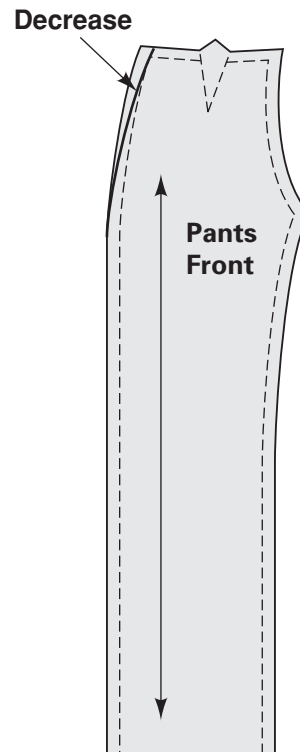

Fig. 8-4

Sewing Casings

In this activity, you will construct a self-casing for elastic. Use the demonstration pattern pieces on page 38.

Supplies

- Fabric piece, 8 in. × 19 in.
- Elastic, 9 in. long, 1 in. wide
- Marking equipment
- Pins
- Large safety pin

Directions: Complete the following steps to create a casing. Use the pattern in **Figure 18-4** on page 38 for your practice sample.

1. Layout, pin, and cut out the casing pattern piece. Transfer the seam line and fold line markings to wrong side of fabric.
2. With right sides together, match the notched edges of fabric and pin in place. Stitch a $\frac{5}{8}$ in. seam. Press seam open. This will create a tube of fabric.
3. Turn under top edge of fabric (near fold line) $\frac{1}{4}$ in. and press. See **Figure 18-1**.
4. Fold fabric, wrong sides together, along fold line to form casing. Pin in place. Press fold of casing.
5. Machine stitch close to lower (free) edge of casing, leaving an opening of 1 to 2 in. at seam line to insert elastic. See **Figure 18-2**.
6. Attach the safety pin to one end of the elastic. Insert the closed safety pin into the casing, using it to pull the elastic through the casing. Be sure to hold the unpinned end of the elastic so that it does not get pulled into the casing. Avoid twisting the elastic.
7. Pull both ends of elastic out through the opening and remove the pin. Overlap the elastic ends $\frac{1}{2}$ in. Stitch a square and then diagonally across the square in the overlapped area to secure the ends of the elastic. See **Figure 18-3**.
8. Close the opening with machine stitching, matching previous stitching lines. Use a backstitch tack to secure your stitching. Turn fabric right side out.

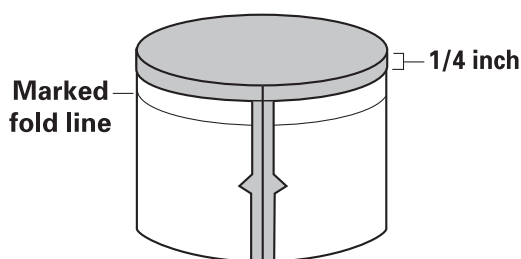

Fig. 18-1

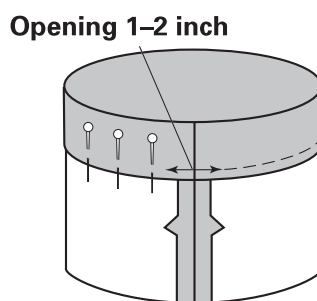

Fig. 18-2

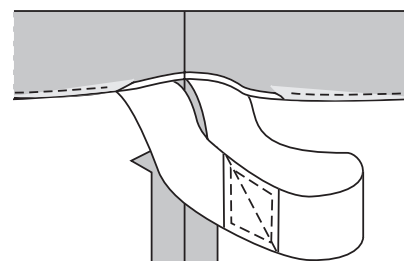

Fig. 18-3

(Continued on next page)

Skill Sheet 8

Sewing Casings (continued)

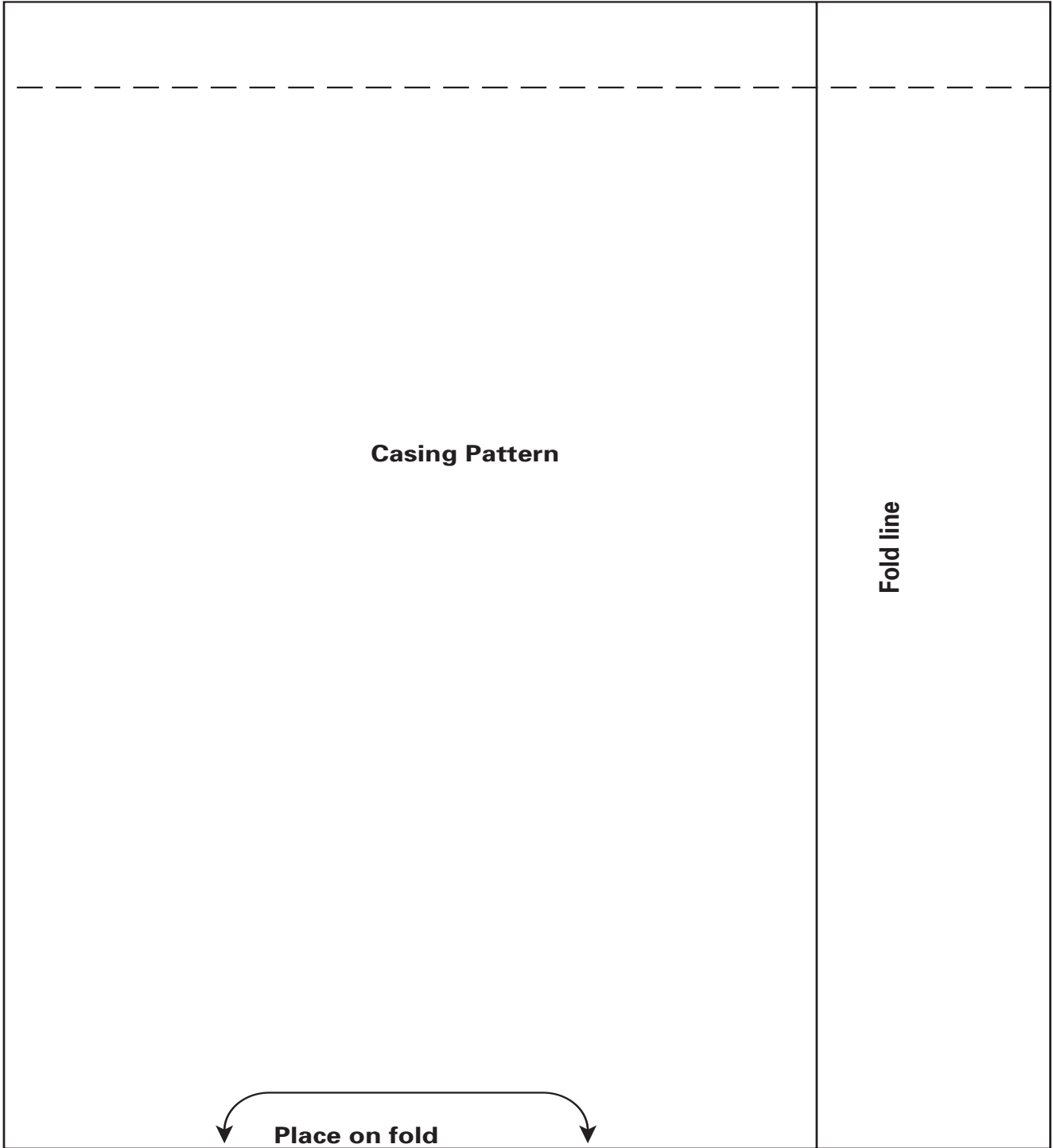

Fig. 18-4

Project 16

Bedside Organizer

Keep nighttime essentials at your fingertips with this clever bedside organizer that slips between the mattress and box springs. This one is made of a hand towel, so there are no edges to finish, but you can adapt these directions to make the organizer in any fabric you choose (even sheets) to coordinate with your bedroom.

Supplies

- 26 in. × 16 in. hand towel
- 5 in. piece of 1-in. wide elastic (optional)

Directions: Complete the following steps to create the bedside organizer.

1. Fold up one end of the towel 7 in. to form the pockets. Pin the side edges together. Topstitch each side using the inside edge of the selvage as a guide, or about ¼ in. from the edge. See **Figure 44-1**.
2. Determine the necessary width of individual pockets by positioning your choice of items—paperback book, cell phone, notepad, TV remote control, eyeglasses, and the like—inside the wide pocket. Mark desired pocket widths. Remove items and smooth out towel. Mark vertical stitching lines. If you will be adding the elastic loop for a water bottle, make at least one pocket 5 in. wide. See **Figure 44-2**.

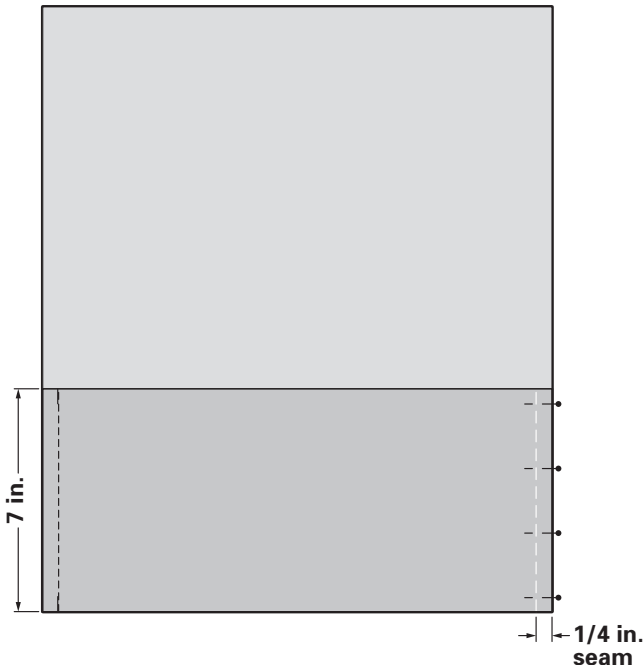
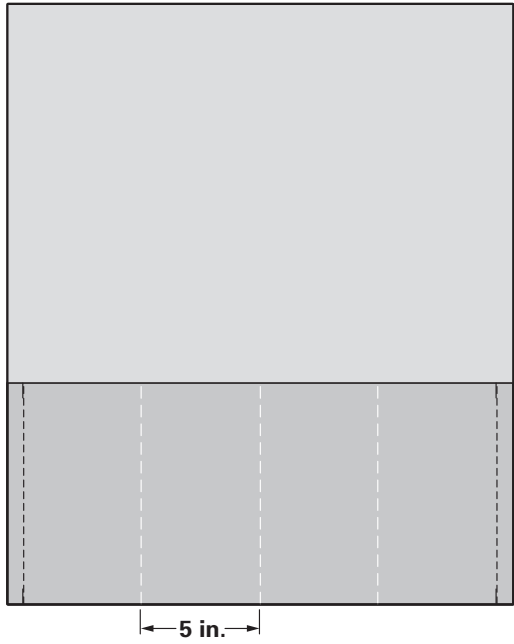

Fig. 44-1



Mark pocket stitching lines

Fig. 44-2

(Continued on next page)

Bedside Organizer (continued)

3. For elastic loop: On the pocket marked to be 5 in. wide, pin the elastic ends on the stitching lines on the pocket flap only, 1½ in. from the upper edge. See **Figure 44-3**.
4. Place only the pocket flap and elastic under the presser foot of the machine and zigzag the elastic ends in place.
5. Pin the pocket flap in place on the pocket stitching lines. Stitch through both layers to form pockets. To make a shallower pocket, stitch again perpendicular to the pocket sides at the desired depth. See **Figure 44-4**.
6. To use, insert the organizer between the mattress and box springs. See **Figure 44-5**.

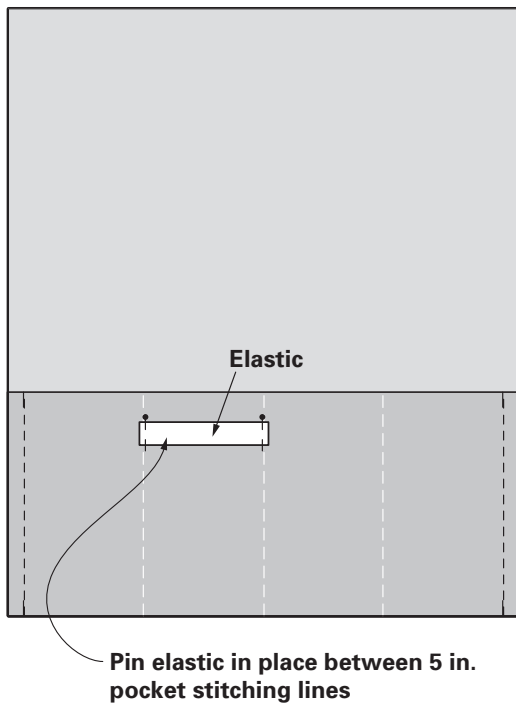

Fig. 44-3

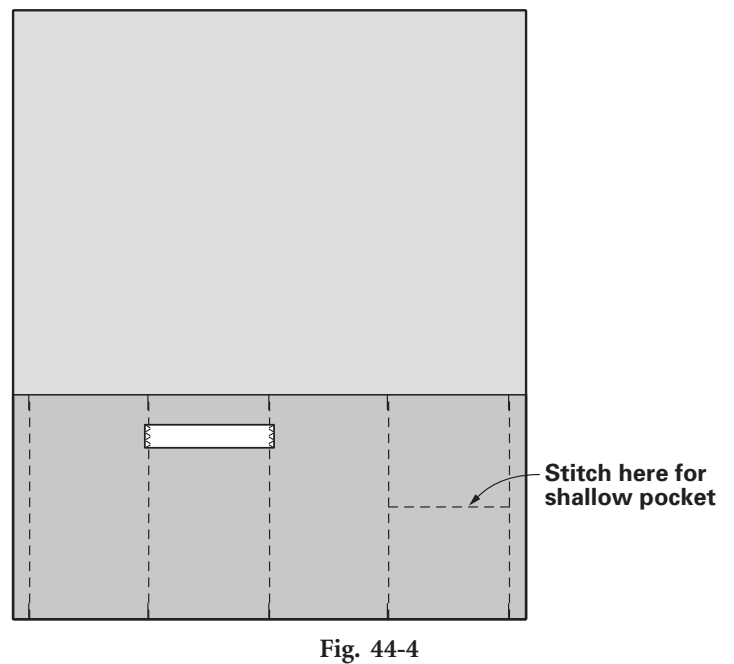

Fig. 44-4

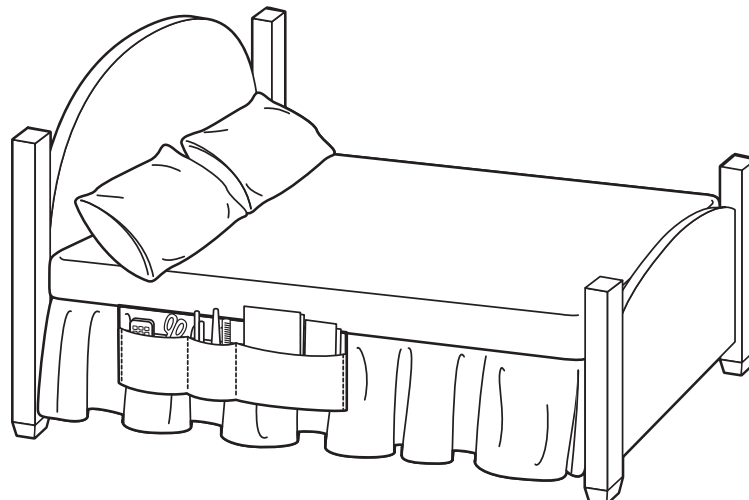

Fig. 44-5