

Messenger Bag

Carry your books and notebooks in style when you make a messenger bag with a shoulder strap. To give your bag sturdiness and durability, choose a tightly woven heavyweight fabric, such as canvas, twill, or a decorator fabric. To add your own designer touch, select a solid-color fabric and embellish it with fabric paints before cutting out the pieces—be sure to let the paint dry overnight before cutting. (Fig. 7-1)

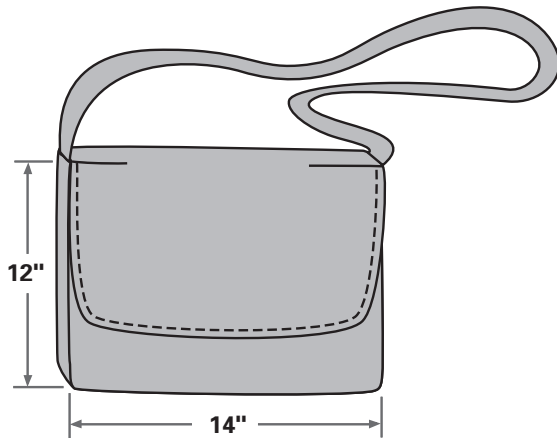

Fig. 7-1

Make your messenger bag in a sturdy fabric, such as denim.

To make the messenger bag, you will need:

- $\frac{3}{4}$ yard (0.7 m) of heavy woven fabric
- $\frac{1}{2}$ yard (0.5 m) of lining fabric
- $\frac{1}{2}$ yard (0.5 m) of fusible medium- to heavy-weight interfacing
- 15 inches (38 cm) of $1\frac{3}{4}$ -inch (4.5-cm) wide grosgrain (GROH-grayn) ribbon to coordinate with woven fabric
- $1\frac{1}{4}$ yards (1.15 m) of $1\frac{1}{2}$ -inch (3.8-cm) wide strap webbing to coordinate with woven fabric
- Thread to match fabric
- Disappearing fabric marker
- Pattern tracing cloth or tracing paper
- Yardstick or wide, clear cutting guide

Directions: Use a $\frac{1}{2}$ -inch (1.3-cm) seam allowance.

1. On the pattern tracing cloth or tracing paper, draw a 15 inch \times 24 inch (38 cm \times 61 cm) rectangle for the bag and a 13 inch \times 15 inch (33 cm \times 38 cm) rectangle for the flap. Round the corners on one end of the flap rectangle as shown. Cut out the patterns. (Fig. 7-2)
2. Cut one bag pattern each from the woven fabric, lining, and interfacing. Cut two flap patterns from the woven fabric and one from interfacing. Fuse each interfacing piece to the wrong side of a corresponding woven fabric piece.
3. Pin the flap pieces together with right sides facing. Sew the sides and curved ends together, leaving the straight edge open. Trim the seam allowance and cut notches in the curves. Turn right side out and press. Topstitch along the sewn edges. Baste the open edges together.
4. Place the woven bag piece right side up on a flat surface. Use the fabric marker to draw a line 3 inches (7.5 cm) from one short end. Apply basting tape to the straight edge of the flap; remove the paper backing and center the flap on the bag rectangle, aligning the lower edge with the marked line. Stitch the flap straight edge to the bag using a wide zigzag stitch, backstitching at the ends to reinforce the stitching. (Fig. 7-3)

(continued on next page)

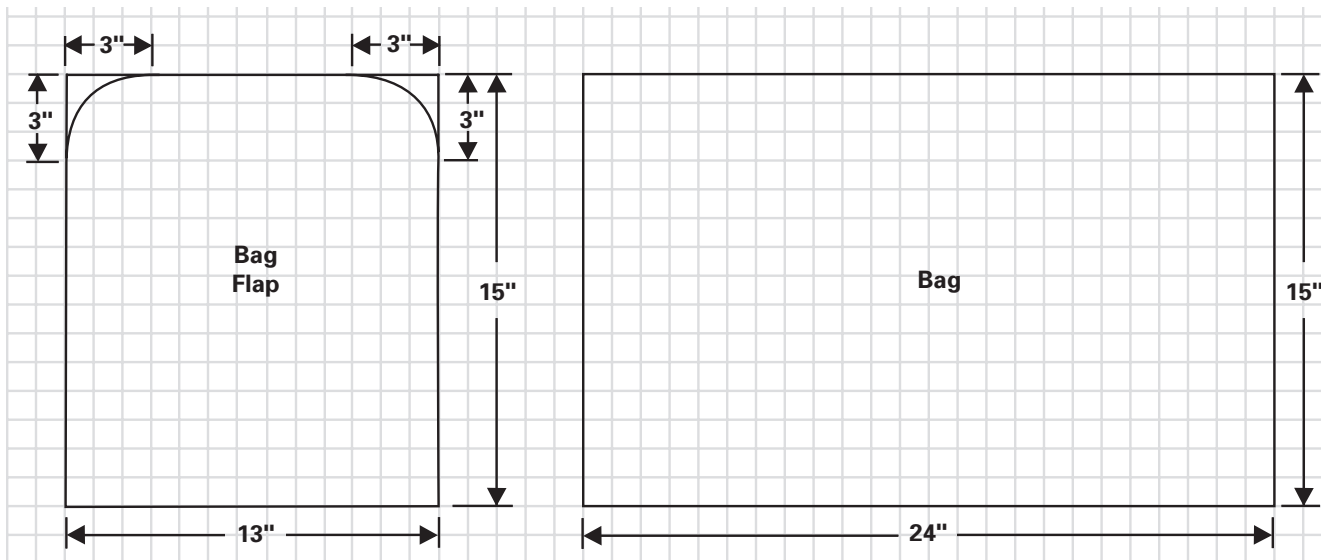

Fig. 7-2

Use one pattern piece for the body of the bag and the other for the flap.

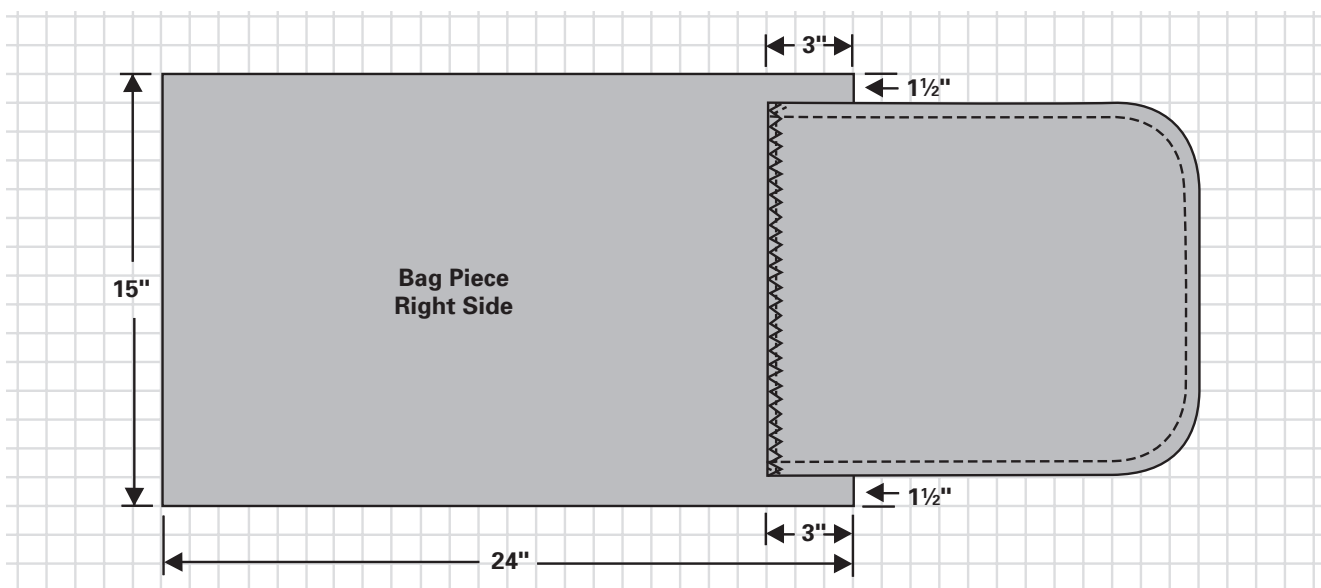

Fig. 7-3

Sew the flap overlapping onto the body of the bag.

5. Apply basting tape to both long edges of the ribbon. Remove the paper backing and adhere the ribbon across the bag, centering it over the marked line and the lower edge of the flap. Edgestitch both edges of the ribbon in place. (Fig. 7-4)
6. Fold the bag in half with right sides together and the edges even. Sew the sides together. Clip the seam allowance to the stitching at the bottom of each side seam. Flatten each side with the seam in the center and press the seam allowances open.

(continued on next page)

Project 7: Messenger Bag (continued)

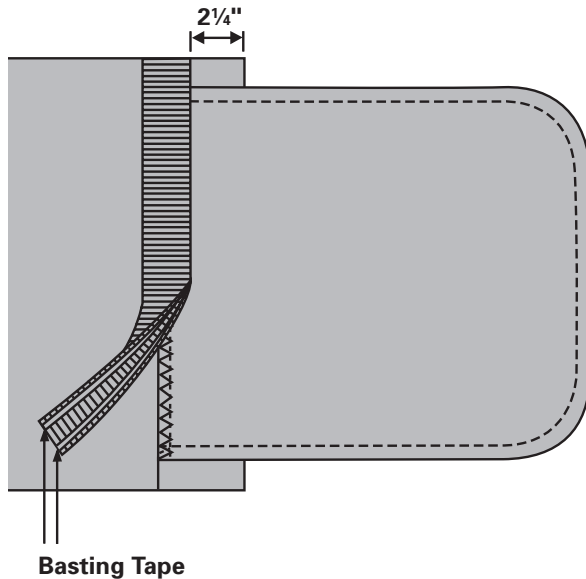

Fig. 7-4

Apply basting tape and ribbon over the raw edge of the bag flap.

- To make each box corner for the bottom of the bag, make sure the side seam is centered on the flattened corner. Measure up 1 inch (2.5 cm) from the bottom of the seam and draw a 2-inch (5-cm) line across the corner, perpendicular to the seam. (Fig. 7-5) Stitch along the line. Trim the point and press it toward the bottom of the bag.

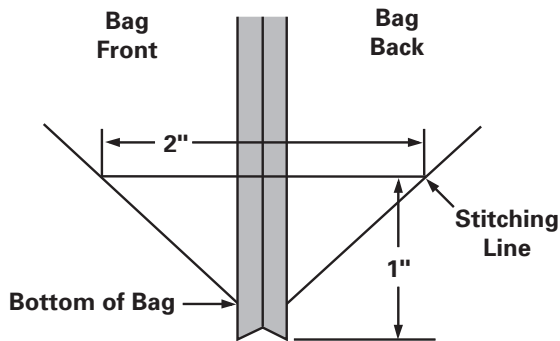

Fig. 7-5

Measure and mark the stitching line for the bag corners.

- Follow Steps 6 and 7 to sew the lining sides and bottom corners. On the lining upper edge, press $\frac{1}{2}$ inch (1.3 cm) to the wrong side.
- Press $\frac{1}{2}$ inch (1.3 cm) to the wrong side on the bag upper edge. Pin one end of the webbing to the inside of the bag at each side seam, overlapping the edge $1\frac{1}{2}$ inches (3.8 cm). Sew the strap ends to the bag, stitching the strap overlap in a square along both sides and across the strap. (Fig. 7-6)

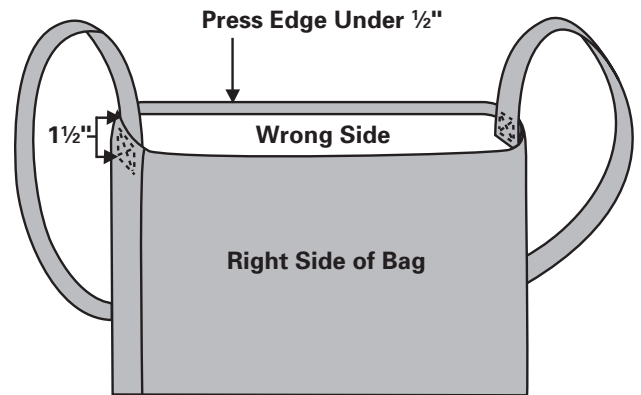

Fig. 7-6

Sew the bag strap ends to each side of the bag.

- Insert the lining in the bag with the side seams aligned and upper edges even; pin the upper edges together. Sew the upper edges together $\frac{1}{4}$ inch (6 mm) from the edge.