

**1-1**

**Skills Practice**

*Using a Problem-Solving Plan*

Solve each problem.

1. **MONEY** Jackie wants to take out an ad in the newspaper for her upcoming garage sale. She can buy a 4-line ad for \$4.35 that will run for three days. If she wants to spend no more than \$15 on advertising, how long can she advertise?
2. **BASEBALL** Cy Young pitched in 815 games over 22 years. He won 511 games. About how many games did he win per year?
3. **MONEY** Each month, Kevin’s car costs \$59 for insurance, \$42 for maintenance, and \$58 for gas. About how much does it cost Kevin to drive his car for a year?
4. **MONEY** How many ways can you make change for a dollar using nickels, dimes, and/or quarters?
5. **FOOD** Friday night Joe decided to order a 1-topping pizza. He had a choice of thin or thick crust and a choice of five toppings (pepperoni, mushrooms, sausage, onions, or peppers). How many different pizzas could he choose from?

Find the next term in each list.

6. 7, 11, 15, 19, 23, ...
7. 2, 4, 8, 16, 32, ...
8. 63, 54, 45, 36, 27, ...
9. 3, 0, 5, 3, 0, 5, ...
10. 0, 4, 8, 12, 16, ...

**GEOMETRY** Draw the next figure in each pattern.

11. □ ▲ □ □ ▲ ▲ □ □ □ ...

12. • •    • • •    • • • •    • • • • • ...

Lesson 1-1

**1-2 Skills Practice*****Numbers and Expressions***

Name the operation that should be performed first. Then find the value of each expression.

1.  $2 - 3 \cdot 0$

2.  $25 \div 5 - 4$

3.  $5 + 2 - 3$

4.  $2 \cdot 5 + 6$

5.  $9 \div 3 \cdot 2 + 1$

6.  $5 + 2 \cdot 8 + 2 - 5$

Find the value of each expression.

7.  $4 + 2 \cdot 8$

8.  $30 - 12 \cdot 2$

9.  $5 + 2 \cdot 3 + 4$

10.  $10 - 2 \cdot 4 - 1$

11.  $15 - 10 \div 2$

12.  $25 - 6 \cdot 4 + 9$

13.  $(14 + 6) \div 5$

14.  $100 + 50 \div 10$

15.  $14 - (4 \cdot 2)$

16.  $(3 + 4) \cdot (5 + 3)$

17.  $6(4 + 5)$

18.  $\frac{8 \cdot 9}{3 \cdot 4}$

19.  $(2 + 3) \cdot 5 + 1$

20.  $24 - 24 \div 8$

21.  $56 \div (3 + 4)$

22.  $2[(4 + 5) \cdot 3]$

Write a numerical expression for each verbal phrase.

23. the difference of seventeen and three

24. eleven more than six

25. the sum of eight, twenty, and thirty-five

26. the quotient of forty and eight

27. one hundred decreased by twenty-five

28. three more than one dozen

29. the product of twenty and thirty

30. five less than fifty

**1-3 Skills Practice*****Variables and Expressions*****ALGEBRA** Evaluate each expression if  $x = 4$ ,  $y = 6$ , and  $z = 3$ .

1.  $x + y + z$

2.  $3x + y$

3.  $x - z$

4.  $x + y - 3z$

5.  $15z$

6.  $3(x + z)$

7.  $xz \div y$

8.  $yz - x$

**ALGEBRA** Evaluate each expression if  $a = 7$ ,  $b = 9$ ,  $c = 2$ , and  $d = 5$ .

9.  $a + b + c$

10.  $a + b - (c + d)$

11.  $3a + 4d$

12.  $bcd$

13.  $(a + b) \cdot (c + d)$

14.  $c(4 + d)$

15.  $\frac{b}{a + c}$

16.  $a + b - 3c$

17.  $ab - cd$

18.  $\frac{bc}{a - d}$

**ALGEBRA** Translate each phrase into an algebraic expression.

19. two inches shorter than Kathryn's height

20. the quotient of some number and thirteen

21. some number added to seventeen

22. six centimeters shorter than the length of the pencil

23. three pounds lighter than Adlai's weight

24. the difference of some number and eighteen

25. three dollars more than the cost of a ticket

26. eight more than the product of a number and four

27. half as many pieces of candy

28. twice as long as the length of the string

**1-4 Skills Practice*****Properties***

Name the property shown by each statement.

1.  $9 \cdot 7 = 7 \cdot 9$

2.  $37 \cdot 0 = 0$

3.  $1 \cdot 87 = 87$

4.  $14 + 6 = 6 + 14$

5.  $3(6a) = (3 \cdot 6)a$

6.  $2b + 0 = 2b$

Find each sum or product mentally.

7.  $4 + 23 + 46$

8.  $327 \cdot 6 \cdot 0$

9.  $2 \cdot 15 \cdot 10$

10.  $5 \cdot 16 \cdot 20$

11.  $14 + 24 + 6 + 26$

12.  $43 + 38 + 7$

13.  $25 \cdot 0 \cdot 8$

14.  $11 + 28 + 19$

**ALGEBRA** Simplify each expression.

15.  $(x + 5) + 4$

16.  $(6a)10$

17.  $38 + (v + 12)$

18.  $8(3q)$

19.  $16p \cdot 0$

20.  $16 + (22 + x)$

21.  $8(9p)$

22.  $(17 + 33) + x$

23.  $3(11k)$

24.  $16 + (y + 9)$

25.  $m(13 \cdot 5)$

26.  $17 + (n + 0)$

**1-5 Skills Practice*****Variables and Equations*****ALGEBRA** Find the solution of each equation from the list given.

1.  $u + 11 = 42$ ; 29, 31, 33

2.  $23 + w = 30$ ; 7, 8, 9

3.  $18 + 17 = g$ ; 33, 34, 35

4.  $s - 16 = 4$ ; 18, 20, 22

5.  $17 - x = 2$ ; 13, 15, 17

6.  $27 - 6 = d$ ; 17, 19, 21

7.  $8r = 24$ ; 3, 4, 5

8.  $16 = 4v$ ; 2, 3, 4

9.  $\frac{42}{x} = 7$ ; 6, 8, 10

10.  $\frac{x}{11} = 7$ ; 73, 75, 77

**ALGEBRA** Solve each equation mentally.

11.  $c + 9 = 11$

12.  $20 = f + 5$

13.  $m - 6 = 3$

14.  $24 - u = 18$

15.  $6r = 36$

16.  $8h = 40$

17.  $p + 9 = 25$

18.  $6 = \frac{30}{z}$

**ALGEBRA** Define a variable. Then write an equation and solve.

19. The product of 5 and a number is 50.

20. A number decreased by 3 is 9.

21. Eleven more than a number is 33.

22. Forty divided by a number is 8.

23. A number times 9 is 36.

24. A number divided by 7 is 7.

25. Thirty less than 40 is a number.

26. The difference between 20 and 8 is a number.

27. The sum of 4 and a number is 20.

28. The quotient of 50 and a number is 2.

# 1-6 Skills Practice

## Ordered Pairs and Relations

Graph each point on the coordinate system.

- 1.  $A(2, 5)$
- 2.  $M(6, 4)$
- 3.  $Z(1, 1)$
- 4.  $R(3, 0)$
- 5.  $Q(7, 8)$
- 6.  $W(0, 6)$

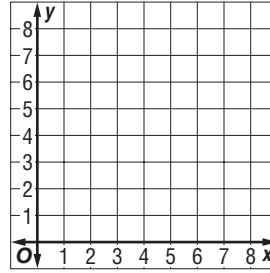

Write the ordered pair that names each point.

- 7.  $N$
- 8.  $K$
- 9.  $A$
- 10.  $V$
- 11.  $Z$
- 12.  $G$
- 13.  $R$
- 14.  $B$

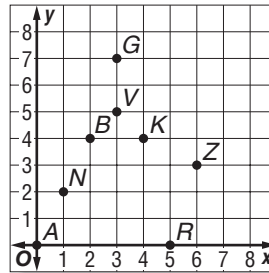

Express each relation as a table and as a graph. Then determine the domain and range.

15.  $\{(3, 7), (1, 1), (6, 5), (2, 4)\}$

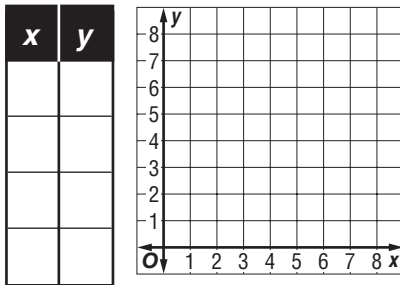

16.  $\{(0, 3), (5, 7), (1, 8)\}$

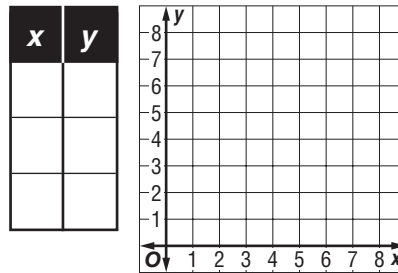

17.  $\{(2, 3), (3, 2), (1, 7), (7, 1)\}$

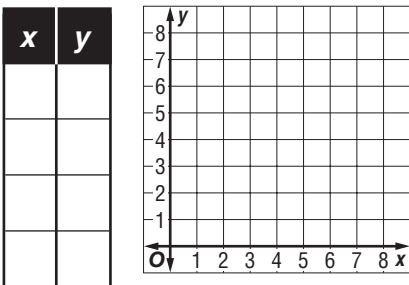

18.  $\{(5, 6), (0, 2), (4, 4), (8, 3)\}$

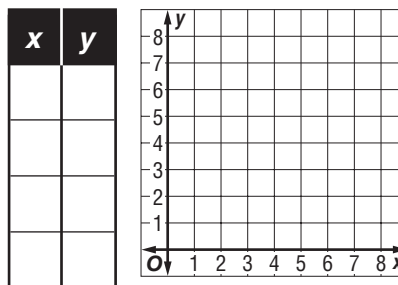

# 1-7 Skills Practice

## Scatter Plots

Tell whether each scatter plot shows a *positive*, *negative*, or *no* relationship.

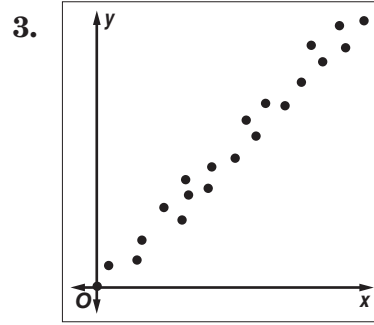
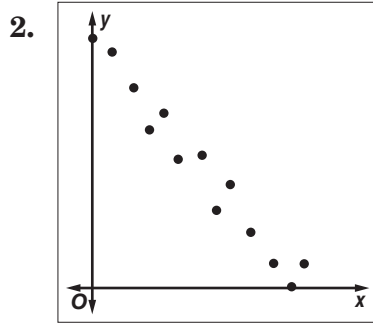
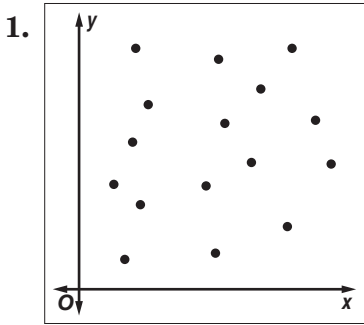

4. Draw a scatter plot with six ordered pairs that shows a positive relationship. Explain your reasoning.

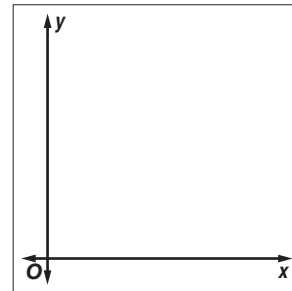

For Exercises 5–8, use the following information:

**SCIENCE** Scientists have determined that there may be a relationship between temperature and the number of chirps produced by crickets. The table gives the temperature and the number of chirps per minute for several cricket samples.

Temperature (°F)	Chirps/min
71	138
68	97
75	152
80	158
60	81
75	155
84	165

5. Make a scatter plot of the data.
6. Does there appear to be a relationship between temperature and chirps? Explain.
7. Suppose the outside temperature is 65°. About how many chirps per minute would you expect from a cricket?
8. Suppose the outside temperature is 55°. About how many chirps per minute would you expect from a cricket?

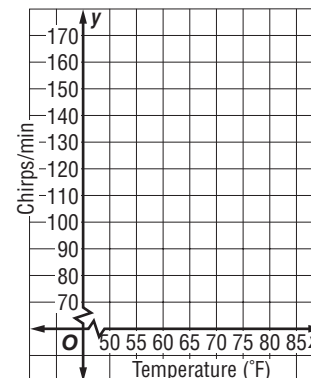

**2-1 Skills Practice*****Integers and Absolute Value***

Replace each  $\bullet$  with  $<$ ,  $>$ , or  $=$  to make a true sentence.

1.  $1 \bullet 0$

2.  $-3 \bullet 0$

3.  $0 \bullet -1$

4.  $0 \bullet 9$

5.  $-7 \bullet -7$

6.  $2 \bullet -2$

7.  $-2 \bullet 8$

8.  $-4 \bullet 4$

9.  $5 \bullet 5$

10.  $0 \bullet -6$

11.  $4 \bullet 10$

12.  $6 \bullet -6$

13.  $3 \bullet 7$

14.  $-1 \bullet -2$

15.  $3 \bullet 4$

16.  $-3 \bullet -4$

Order the integers in each set from least to greatest.

17.  $\{4, -5, 0\}$

18.  $\{8, -2, 1\}$

19.  $\{-6, -3, 0\}$

20.  $\{-5, 5, 3, -1\}$

21.  $\{0, -3, 7, -2\}$

22.  $\{9, -11, 1, 0\}$

23.  $\{12, -4, 3, -1\}$

24.  $\{-8, 15, 1, -10\}$

25.  $\{-12, -17, -20, 2\}$

Evaluate each expression.

26.  $|1|$

27.  $|-10|$

28.  $|-8|$

29.  $|10|$

30.  $|4| + |-4|$

31.  $|9| - |-5|$

32.  $0 + |-1|$

33.  $|-6| + |-5|$

34.  $|-8| - |-8|$

35.  $|12| + |-3|$

36.  $|-15| - |6|$

37.  $|-13| + |-7|$

Evaluate each expression if  $a = -3$ ,  $b = 0$ , and  $c = 1$ .

38.  $|a| - b$

39.  $|c| + 2$

40.  $9 - |a|$

41.  $|25| - b$

42.  $10 - |b|$

43.  $|-8| + |a|$



## 2-2 Skills Practice

### *Adding Integers*

Find each sum.

1.  $-7 + (-5)$

2.  $10 + 9$

3.  $-12 + (-5)$

4.  $-13 + (-3)$

5.  $-10 + 12$

6.  $-7 + 8$

7.  $-11 + (-6)$

8.  $0 + (-21)$

9.  $72 + (-10)$

10.  $72 + 10$

11.  $-13 + (-11)$

12.  $-52 + 52$

13.  $-6 + (-12)$

14.  $14 + (-8)$

15.  $-17 + (-2)$

16.  $50 + (-8)$

17.  $-22 + 4$

18.  $14 + 8$

19.  $-21 + (-9)$

20.  $15 + (-5)$

21.  $9 + 10$

22.  $-12 + (-15)$

23.  $-13 + 6$

24.  $-1 + (-18)$

25.  $0 + 31$

26.  $-45 + (-15)$

27.  $-6 + 20$

28.  $24 + (-11)$

29.  $7 + (-14)$

30.  $-34 + (-10)$

31.  $-8 + (-25)$

32.  $-31 + 25$

33.  $6 + 5 + (-4)$

34.  $-4 + (-5) + 6$

35.  $-3 + 8 + (-9)$

36.  $-6 + (-2) + (-1)$

37.  $10 + (-5) + 6$

38.  $-8 + 8 + (-10)$

39.  $0 + (-8) + 22$

40.  $-31 + 19 + (-15)$

41.  $32 + (-4) + (-9)$

**2-3****Skills Practice*****Subtracting Integers*****Find each difference.**

1.  $-2 - (-8)$

2.  $4 - (-11)$

3.  $-7 - 6$

4.  $15 - 2$

5.  $-7 - (-1)$

6.  $1 - 9$

7.  $-5 - (-3)$

8.  $6 - (-5)$

9.  $-4 - (-10)$

10.  $4 - 6$

11.  $0 - (-15)$

12.  $-16 - (-10)$

13.  $0 - 16$

14.  $11 - (-9)$

15.  $-9 - 1$

16.  $-1 - (-8)$

17.  $1 - (-2)$

18.  $-2 - (-19)$

19.  $13 - 17$

20.  $20 - (-15)$

21.  $-10 - (-21)$

22.  $4 - 22$

23.  $-8 - 16$

24.  $12 - (-9)$

**Evaluate each expression if  $a = -9$ ,  $b = 4$ , and  $c = -5$ .**

25.  $a - 8$

26.  $10 - c$

27.  $11 - b$

28.  $15 - a$

29.  $-8 - b$

30.  $c - 1$

31.  $-32 - a$

32.  $b - 25$

33.  $c - (-14)$

34.  $-33 - a$

35.  $14 - c$

36.  $b - c$

37.  $a - c$

38.  $b - a$

39.  $c - b$

40.  $c - a$

41.  $a - b$

42.  $a + b - c$

43.  $b + 15 + a$

44.  $a - (-b) + c$

## 2-4 Skills Practice

### *Multiplying Integers*

Find each product.

1.  $-2(8)$

2.  $-4(-4)$

3.  $6(-2)$

4.  $-7(-3)$

5.  $12(1)$

6.  $0(-2)$

7.  $-11(5)$

8.  $-9(-3)$

9.  $-13(0)$

10.  $-1(-1)$

11.  $-1(1)$

12.  $1(-1)$

13.  $-5(20)$

14.  $16(-2)$

15.  $18(-3)$

16.  $-5(-5)$

17.  $8(6)(-2)$

18.  $-1(50)(-1)$

19.  $6(0)(-2)$

20.  $(-3)(-2)(-1)$

21.  $-4(5)(-3)$

22.  $10(-3)(2)$

23.  $-9(8)(1)$

24.  $-1(-1)(-1)$

**ALGEBRA** Simplify each expression.

25.  $-2 \cdot 3x$

26.  $-4 \cdot 5y$

27.  $9 \cdot (-2z)$

28.  $-5 \cdot (-6a)$

29.  $8t \cdot (-3)$

30.  $2n \cdot (-1)$

31.  $-5 \cdot 2w$

32.  $8c \cdot (-2)$

33.  $-3c \cdot (-5d)$

34.  $4r \cdot 7s$

35.  $-3x \cdot (-z)$

36.  $-4ab \cdot (-6)$

37.  $(-3)(4)(-x)$

38.  $-3(5)(-y)$

39.  $(-6)(-2)(8r)$

40.  $-5(0)(-xy)$

**ALGEBRA** Evaluate each expression if  $x = -5$  and  $y = -6$ .

41.  $3y$

42.  $-8x$

43.  $-4y$

44.  $12x$

45.  $xy$

46.  $-xy$

47.  $-6xy$

48.  $4xy$

## 2-5 Skills Practice

### Dividing Integers

Find each quotient.

1.  $16 \div 4$

2.  $-27 \div 3$

3.  $25 \div (-5)$

4.  $63 \div (-9)$

5.  $-15 \div (-3)$

6.  $14 \div (-7)$

7.  $-124 \div 4$

8.  $60 \div 15$

9.  $28 \div (-4)$

10.  $-56 \div (-8)$

11.  $72 \div 8$

12.  $-21 \div (-7)$

13.  $\frac{-32}{4}$

14.  $\frac{45}{9}$

15.  $\frac{-45}{3}$

16.  $\frac{-25}{-5}$

17.  $\frac{35}{-7}$

18.  $\frac{-63}{-7}$

19.  $\frac{-144}{12}$

20.  $\frac{48}{-6}$

21. What is  $-54$  divided by  $9$ ?22. Divide  $-27$  by  $-3$ .23. Divide  $144$  by  $-12$ .24. What is  $-65$  divided by  $-13$ ?

Evaluate each expression if  $x = -8$  and  $y = -12$ .

25.  $x \div 2$

26.  $x \div (-4)$

27.  $36 \div y$

28.  $0 \div y$

29.  $-60 \div y$

30.  $56 \div x$

31.  $8 \div x$

32.  $-108 \div y$

33.  $\frac{x}{-2}$

34.  $\frac{y}{3}$

35.  $\frac{0}{x}$

36.  $\frac{-112}{x}$

37.  $\frac{y}{-6}$

38.  $\frac{x}{4}$

39.  $\frac{-144}{y}$

40.  $\frac{-136}{x}$

Find the average (mean) of each group of numbers.

41. 3, 12, 6

42.  $-8, -1, -3$

43.  $-8, 15, 5, 8$

44.  $-3, -10, 2, -4, 0$

45.  $-10, -7, 7, 10$

46. 12, 24, 9, 15, 18, 20, 16, 14

47.  $-4, -11, -6, 1, 8, -12$

# 2-6 Skills Practice

## The Coordinate System

Name the ordered pair for each point graphed at the right.

- 1. *A*
- 2. *B*
- 3. *C*
- 4. *D*
- 5. *E*
- 6. *F*
- 7. *G*
- 8. *H*
- 9. *I*
- 10. *J*

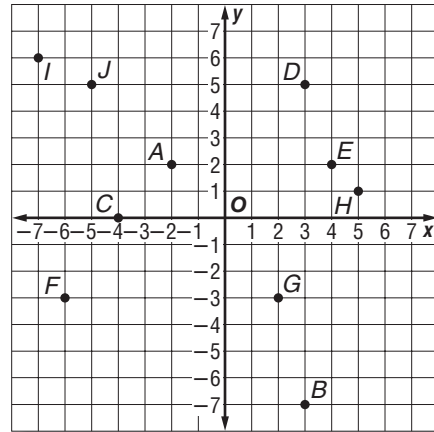

Graph and label each point on the coordinate plane. Name the quadrant in which each point is located.

- 11.  $K(1, 0)$
- 12.  $L(0, 2)$
- 13.  $M(-2, 4)$
- 14.  $N(-5, -4)$
- 15.  $P(6, -2)$
- 16.  $Q(7, -6)$
- 17.  $R(-3, -4)$
- 18.  $S(4, -7)$
- 19.  $T(3, 6)$
- 20.  $U(-7, 4)$

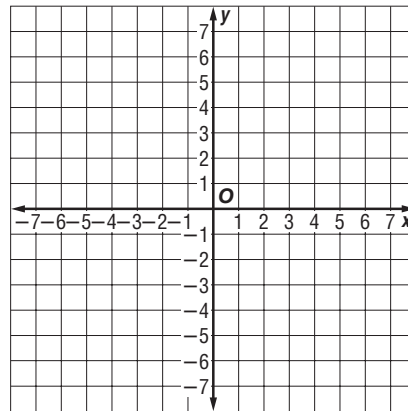

21. **ALGEBRA** Make a table of values and graph six sets of ordered pairs for the equation  $y = x - 4$ . Describe the graph.

$y = x - 4$		
$x$	$y$	$(x, y)$

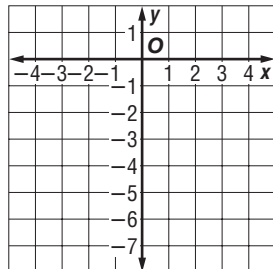

**3-1 Skills Practice*****The Distributive Property***

Use the Distributive Property to write each expression as an equivalent expression. Then evaluate the expression.

1.  $8(50 + 4)$

2.  $(20 + 9)5$

3.  $2(60 + 4)$

4.  $7(40 - 2)$

5.  $4(400 - 2)$

6.  $-4(16 + 5)$

7.  $-8(4 + 1)$

8.  $9(24 - 19)$

9.  $-3(7 - 11)$

10.  $-10(12 - 4)$

11.  $(21 + 9)(-5)$

12.  $-7(1 - 10)$

13.  $-2(1 - 6)$

14.  $4(15 + 25)$

15.  $15(100 + 6)$

16.  $12(22 - 52)$

Use the Distributive Property to write each expression as an equivalent algebraic expression.

17.  $4(d + 2)$

18.  $1(u - 3)$

19.  $-6(f + 5)$

20.  $-2(g - 3)$

21.  $3(x - 7)$

22.  $8(-b + 4)$

23.  $(9 - h)5$

24.  $(c + 1)(-4)$

25.  $-1(2 - y)$

26.  $-7(a + 1)$

27.  $11(k - 20)$

28.  $-9(r - 1)$

29.  $5(1 - b)$

30.  $8(x + 12)$

31.  $-6(p + 15)$

32.  $4(h - 16)$

33.  $-3(w - 10)$

34.  $-10(c + 9)$

35.  $2(11 - q)$

36.  $-4(12 - f)$

37.  $12(n + 2)$

38.  $16(g + 1)$

39.  $-8(9 + b)$

40.  $-5(z - 4)$

41.  $6(r - 20)$

42.  $7(2 - j)$

43.  $-1(m + 1)$

44.  $-2(v - 8)$

45.  $5(q - 16)$

46.  $-10(c - 7)$

47.  $-3(-x - 1)$

48.  $(9 - h)(-2)$

**3-2 Skills Practice*****Simplifying Algebraic Expressions*****Simplify each expression.**

1.  $7a + a$

2.  $k - k$

3.  $m + 3m + 8$

4.  $10b - b + 1$

5.  $9j + 8j - 7j$

6.  $6y + 3y + 6y - 2y$

7.  $3q + 2q - q$

8.  $18 + 7x - 12 + 5x$

9.  $12a + 3 + 18 - 9a$

10.  $13c - 7 + c - d$

11.  $5h + h - 4h + 1 - 2h$

12.  $2(v - 5) + 7v + 4$

13.  $5(r + 9) - 5$

14.  $1 - 4(u - 1)$

15.  $-7(w - 4) + 3w - 27$

16.  $-8 - 7(y + 2)$

17.  $-18(c - 1) - 18$

18.  $12(n - 4) - 3n$

19.  $5m - 9 + 4m$

20.  $-7 + g + 1 - 6g$

21.  $x - 9x + 3 + 8x - 3$

22.  $6(r - 4) + r + 30 - 7r$

23.  $-5 + 5a - 4 - 2a + 3a$

24.  $21 - 8(v + 3) + 3 + 7v$

25.  $4x - 9 + 3x + 6 - 9x - 4$

26.  $p - 2 + 1 - p + 1 + 2p$

27.  $-11f + 6 - f + 4 + 13f - 9$

28.  $3(d - 4) + 2 - 2d + 1 - d$

29.  $1 - s + 2 + 2s - 3s + 1$

30.  $5 - 9k + 1 + k - 2(7 - k)$

31.  $1 - g + 5 - 2g + 3(g - 2)$

32.  $7h + 1 - h + 4 - 2 - 8h$

33.  $-12 + 7(d - 1) + 14 - d$

**3-3 Skills Practice*****Solving Equations by Adding or Subtracting***

Solve each equation. Check your solution.

1.  $r + 1 = -5$

2.  $h + 8 = 6$

3.  $t - 3 = -11$

4.  $p - 5 = 9$

5.  $w + 9 = -9$

6.  $x - 9 = -9$

7.  $a + 7 = -7$

8.  $m + 9 = -7$

9.  $q - 4 = 5$

10.  $b + 2 = 3$

11.  $n - 11 = 1$

12.  $r - 1 = -3$

13.  $c + 6 = 1$

14.  $v - 3 = -7$

15.  $z + 3 = 0$

16.  $s - 8 = -1$

17.  $y - 7 = -5$

18.  $u - 10 = -2$

19.  $g + 1 = 10$

20.  $k + 4 = -9$

21.  $w + 12 = -4$

22.  $z - 8 = -8$

23.  $d - 11 = 1$

24.  $h + 3 = 10$

25.  $r + 10 = -6$

26.  $y + 1 = 4$

27.  $f - 6 = 6$

28.  $d - 2 = -8$

29.  $j + 11 = 4$

30.  $m - 10 = 4$

31.  $q + 3 = -5$

32.  $g - 4 = 0$

33.  $a - 12 = -19$

34.  $c + 5 = 2$

35.  $h - 9 = 12$

36.  $p + 14 = -1$

37.  $v + 13 = -11$

38.  $x + 8 = -1$

39.  $y + 12 = -10$

40.  $k - 16 = 7$

41.  $d - 15 = -14$

42.  $g - 12 = 10$

43.  $b + 13 = -20$

44.  $f - 15 = -1$

45.  $q + 8 = 13$

46.  $w - 4 = -15$

47.  $r + 10 = -13$

48.  $t - 11 = 11$

49.  $j - 9 = -8$

50.  $k + 2 = -15$

51.  $n + 12 = 0$

52.  $y + 9 = 14$



**3-4 Skills Practice*****Solving Equations by Multiplying or Dividing***

Solve each equation. Check your solution.

1.  $3x = 24$

2.  $\frac{m}{-5} = -15$

3.  $-4f = 16$

4.  $\frac{u}{2} = 12$

5.  $-6a = 6$

6.  $\frac{s}{-1} = 10$

7.  $-2y = -2$

8.  $-7z = 7$

9.  $\frac{n}{8} = -24$

10.  $-4r = -12$

11.  $-9h = 81$

12.  $\frac{c}{-10} = 1$

13.  $\frac{v}{-15} = -15$

14.  $\frac{m}{12} = 0$

15.  $-12g = 12$

16.  $\frac{w}{-4} = 0$

17.  $-1f = 11$

18.  $\frac{r}{-1} = 22$

19.  $8d = -16$

20.  $\frac{r}{15} = 45$

21.  $25k = -200$

22.  $-3p = 18$

23.  $7j = -63$

24.  $\frac{y}{-10} = 10$

25.  $\frac{x}{-8} = -1$

26.  $5g = -20$

27.  $\frac{p}{6} = 0$

28.  $7y = 7$

29.  $-6q = -30$

30.  $-12c = -60$

31.  $-9b = 90$

32.  $-4k = -120$

33.  $2r = 0$

34.  $-1t = 19$

35.  $\frac{n}{-12} = 12$

36.  $-15j = 120$

37.  $\frac{u}{-11} = 11$

38.  $5c = 85$

39.  $-9q = -36$

40.  $9z = -144$

**3-5 Skills Practice*****Solving Two-Step Equations***

Solve each equation. Check your solution.

1.  $3x + 10 = 1$

2.  $\frac{a}{5} + 8 = 9$

3.  $8w - 12 = -4$

4.  $\frac{r}{2} + 6 = 5$

5.  $18 - 2q = 4$

6.  $3j - 20 = 16$

7.  $\frac{u}{12} - 8 = -8$

8.  $7p + 11 = -31$

9.  $12d + 15 = 3$

10.  $4c + 20 = 0$

11.  $\frac{n}{2} - 9 = -5$

12.  $10b - 19 = 11$

13.  $2h + 10 = -12$

14.  $6k - 9 = 15$

15.  $\frac{w}{-5} - 4 = -2$

16.  $12 - 7y = -2$

17.  $11 - 3g = 32$

18.  $12s + 13 = 25$

19.  $2z - 4 - z = 4$

20.  $10 - 5h + 2 = 32$

21.  $\frac{r}{-7} - 5 = -6$

22.  $-4a + 5 - 2a - 9 = 44$

23.  $\frac{w}{-3} + 6 - 1 = 2$

24.  $7k - 8k = 1$

25.  $7f - 24 = 25$

26.  $6 - \frac{m}{6} - 8 = 0$

27.  $10 - d = 19$

28.  $9x + 5 - 4x = -20$

29.  $3 - 4t + 11 = 2$

30.  $\frac{a}{3} - 4 + 9 = 7$

31.  $6q - 4 = -16$

32.  $\frac{m}{8} - 12 - 3 = -12$

33.  $5b + 6 - 6b + 2 = 19$

**3-6 Skills Practice*****Writing Two-Step Equations***

**Translate each sentence into an equation. Then find each number.**

1. Eleven less than 5 times a number is 24.
2. The quotient of a number and  $-9$  increased by 10 is 11.
3. Five less than the product of  $-3$  and a number is  $-2$ .
4. Fifteen more than twice a number is  $-23$ .
5. The difference between 5 times a number and 4 is 16.
6. Nine more than  $-8$  times a number is  $-7$ .
7. The difference between 12 and ten times a number is  $-28$ .
8. Seven more than three times a number is 52.
9. Eleven less than five times a number is 19.
10. Thirteen more than four times a number is  $-91$ .
11. Seven less than twice a number is 43.

**Solve each problem by writing and solving an equation.**

12. **SHOPPING** The total cost of a suit and 4 ties is \$292. The suit cost \$200. Each tie cost the same amount. Find the cost of one tie.
13. **AGES** Mary's sister is 7 years older than Mary. Their combined ages add up to 35. How old is Mary?

**3-7 Skills Practice*****Sequences and Equations***

Describe each sequence using words and symbols.

1. 7, 8, 9, 10, ...

2. 5, 6, 7, 8, ...

3. 7, 14, 21, 28, ...

4. 12, 24, 36, 48, ...

5. 3, 5, 7, 9, ...

6. 12, 21, 30, 39, ...

7. 55, 62, 69, 76, ...

8. 3, 21, 39, 57, ...

Write an equation that describes each sequence. Then find the indicated term.

9. 5, 8, 11, 14, ...; 9th term

10. 7, 16, 25, 34, ...; 15th term

11. 7, 9, 11, 13, ...; 18th term

12. 4, 10, 16, 22, ...; 10th term

13. 6, 17, 28, 39, ...; 8th term

14. 25, 44, 53, 62, ...; 12th term

15. 26, 29, 32, 35, ...; 14th term

16. 61, 83, 105, 127, ...; 20th term

# 3-8 Skills Practice

## Using Formulas

- AIR TRAVEL** A plane is traveling 9 miles per minute. How much time is needed to travel 216 miles?
- JOGGING** What is the rate, in feet per second, of a girl who jogs 315 feet in 45 seconds?

Find the perimeter and area of each rectangle.

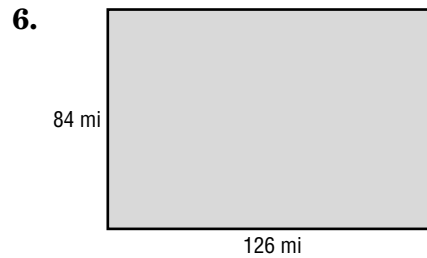
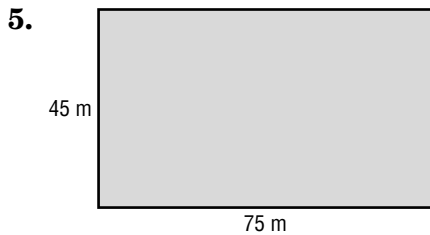
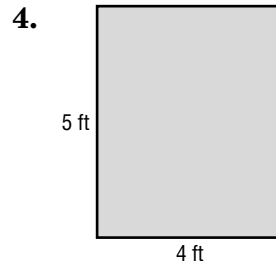
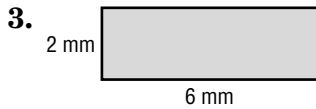

- a rectangle that is 21 inches long and 13 inches wide
- a square that is 25 centimeters on each side

Find the missing dimension of each rectangle.

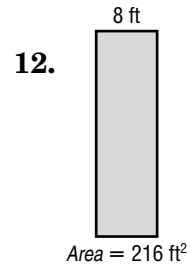
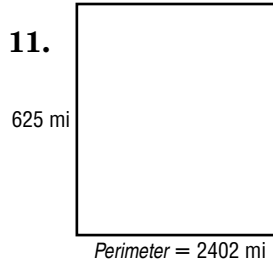
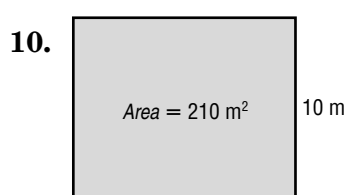
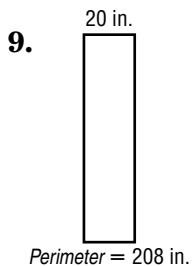

- The perimeter of a rectangle is 100 centimeters. Its width is 9 centimeters. Find its length.
- The area of a rectangle is 319 square kilometers. Its width is 11 kilometers. Find its length.

**4-1 Skills Practice*****Powers and Exponents*****Write each expression using exponents.**

1.  $7 \cdot 7$

2.  $(-3)(-3)(-3)(-3)(-3)$

3.  $4$

4.  $(k \cdot k)(k \cdot k)(k \cdot k)$

5.  $p \cdot p \cdot p \cdot p \cdot p \cdot p$

6.  $3 \cdot 3$

7.  $(-a)(-a)(-a)(-a)$

8.  $6 \cdot 6 \cdot 6 \cdot 6$

9.  $9 \cdot 9 \cdot 9$

10.  $4 \cdot y \cdot z \cdot z \cdot z$

11.  $s \cdot s \cdot s \cdot s \cdot s \cdot t \cdot u \cdot u$

12.  $5 \cdot 5 \cdot 5 \cdot q \cdot q$

**Express each number in expanded form.**

13. 135

14. 8732

15. 1005

16. 989

**Evaluate each expression if  $b = 8$ ,  $c = 2$ , and  $d = -3$ .**

17.  $4^c$

18.  $c^0$

19.  $b^3$

20.  $c^3 \cdot 3^c$

21.  $3^c$

22.  $c^4$

23.  $c^2 + d$

24.  $2b^2$

25.  $b^2 + c^3$

26.  $d^2$

27.  $d^3$

28.  $b^2 + d^3$

29.  $b^2d$

30.  $(b - c)^2$

**4-2 Skills Practice*****Prime Factorization***

Determine whether each number is *prime* or *composite*.

1. 41

2. 29

3. 87

4. 36

5. 57

6. 61

7. 71

8. 103

9. 39

10. 91

11. 47

12. 67

Write the prime factorization of each number. Use exponents for repeated factors.

13. 20

14. 40

15. 32

16. 44

17. 90

18. 121

19. 46

20. 30

21. 65

22. 80

Factor each monomial.

23.  $15t$

24.  $16r^2$

25.  $-11m^2$

26.  $-49y^3$

27.  $21ab$

28.  $-42xyz$

29.  $45j^2k$

30.  $17u^2v^2$

31.  $27d^4$

32.  $-16cd^2$

**4-3 Skills Practice*****Greatest Common Factor (GCF)*****Find the GCF of each set of numbers or monomials.**

1. 15, 50

2. 24, 81

3. 18, 27

4. 36, 64

5. 88, 40

6. 54, 63

7. 11, 22

8. 14, 25

9. 20, 30

10. 16, 18

11. 64, 80

12. 16, 24

13.  $30t$ ,  $40t^2$

14.  $6$ ,  $9t$

15.  $16k^2$ ,  $40k$

16.  $9m$ ,  $15n$

17.  $7pq$ ,  $8q$

18.  $18p$ ,  $45$

**Factor each expression.**

19.  $5b + 15$

20.  $7t + 49$

21.  $6w + 18$

22.  $100 + 50x$

23.  $7x + 7$

24.  $12n + 60$

25.  $24 + 8g$

26.  $50 + 5f$

27.  $3n + 24$

28.  $9\ell + 63$

29.  $6u + 36$

30.  $70 - 7c$

31.  $42 - 21x$

32.  $12y + 16$

33.  $6p - 12$

34.  $9r - 81$

35.  $6 + 8q$

36.  $21x + 33$



**4-4 Skills Practice*****Simplifying Algebraic Fractions***

Write each fraction in simplest form. If the fraction is already in simplest form, write *simplified*.

1.  $\frac{10}{70}$

2.  $\frac{12}{18}$

3.  $\frac{30}{45}$

4.  $\frac{8}{24}$

5.  $\frac{4}{6}$

6.  $\frac{56}{63}$

7.  $\frac{18}{24}$

8.  $\frac{7}{49}$

9.  $\frac{13}{39}$

10.  $\frac{21}{36}$

11.  $\frac{32}{40}$

12.  $\frac{4}{36}$

13.  $\frac{44}{55}$

14.  $\frac{4}{14}$

15.  $\frac{36}{48}$

16.  $\frac{81}{90}$

17.  $\frac{5}{25}$

18.  $\frac{56}{74}$

19.  $\frac{22}{42}$

20.  $\frac{7}{18}$

21.  $\frac{d^3}{d^4}$

22.  $\frac{y}{y^3}$

23.  $\frac{q^3}{q}$

24.  $\frac{s^4}{s^2}$

25.  $\frac{x^2}{y}$

26.  $\frac{9a}{12a}$

27.  $\frac{8t}{16t}$

28.  $\frac{14g}{24g}$

29.  $\frac{35j}{40}$

30.  $\frac{100p}{200p^2}$

31.  $\frac{75n}{100n^3}$

32.  $\frac{6k^5}{21k^2}$

33.  $\frac{3a}{4b}$

34.  $\frac{16b}{24d}$

35.  $\frac{8a}{24a}$

36.  $\frac{5t^3}{35t^2}$

**4-5 Skills Practice*****Multiplying and Dividing Monomials***

Find each product or quotient. Express your answer using exponents.

1.  $2^3 \cdot 2^5$

2.  $10^2 \cdot 10^7$

3.  $1^4 \cdot 1$

4.  $6^3 \cdot 6^3$

5.  $(-3)^2(-3)^3$

6.  $(-9)^2(-9)^2$

7.  $a^2 \cdot a^3$

8.  $n^8 \cdot n^3$

9.  $(p^4)(p^4)$

10.  $(z^6)(z^7)$

11.  $(6b^3)(3b^4)$

12.  $(-v)^3(-v)^7$

13.  $11a^2 \cdot 3a^6$

14.  $10t^2 \cdot 4t^{10}$

15.  $(8c^2)(9c)$

16.  $(4f^8)(5f^6)$

17.  $\frac{5^{10}}{5^2}$

18.  $\frac{10^6}{10^2}$

19.  $\frac{7^9}{7^6}$

20.  $\frac{12^8}{12^3}$

21.  $\frac{100^9}{100^8}$

22.  $\frac{(-2)^3}{-2}$

23.  $\frac{r^8}{r^7}$

24.  $\frac{z^{10}}{z^8}$

25.  $\frac{q^8}{q^4}$

26.  $\frac{g^{12}}{g^8}$

27.  $\frac{(-y)^7}{(-y)^2}$

28.  $\frac{(-z)^{12}}{(-z)^5}$

29. the product of two squared and two to the sixth power

30. the quotient of ten to the seventh power and ten cubed

31. the product of  $y$  squared and  $y$  cubed32. the quotient of  $a$  to the twentieth power and  $a$  to the tenth power

**4-6 Skills Practice*****Negative Exponents***

Write each expression using a positive exponent.

1.  $3^{-4}$

2.  $8^{-7}$

3.  $10^{-4}$

4.  $(-2)^{-6}$

5.  $(-40)^{-3}$

6.  $(-17)^{-12}$

7.  $n^{-10}$

8.  $b^{-8}$

9.  $q^{-5}$

10.  $m^{-4}$

11.  $v^{-11}$

12.  $p^{-2}$

Write each fraction as an expression using a negative exponent other than  $-1$ .

13.  $\frac{1}{8^2}$

14.  $\frac{1}{10^5}$

15.  $\frac{1}{2^3}$

16.  $\frac{1}{6^7}$

17.  $\frac{1}{17^4}$

18.  $\frac{1}{21^2}$

19.  $\frac{1}{3^7}$

20.  $\frac{1}{9^2}$

21.  $\frac{1}{3^2}$

22.  $\frac{1}{121}$

23.  $\frac{1}{25}$

24.  $\frac{1}{36}$

Evaluate each expression if  $x = 1$ ,  $y = 2$ , and  $z = -3$ .

25.  $y^{-z}$

26.  $z^{-2}$

27.  $x^{-8}$

28.  $y^{-5}$

29.  $z^{-3}$

30.  $y^{-1}$

31.  $z^{-4}$

32.  $5^z$

33.  $x^{-99}$

34.  $1^z$

35.  $4^z$

36.  $y^z$

**4-7 Skills Practice****Scientific Notation****Express each number in standard form.**

- |                           |                            |
|---------------------------|----------------------------|
| 1. $1.5 \times 10^3$      | 2. $4.01 \times 10^4$      |
| 3. $6.78 \times 10^2$     | 4. $5.925 \times 10^6$     |
| 5. $7.0 \times 10^8$      | 6. $9.99 \times 10^7$      |
| 7. $3.0005 \times 10^5$   | 8. $2.54 \times 10^5$      |
| 9. $1.75 \times 10^4$     | 10. $1.2 \times 10^{-6}$   |
| 11. $7.0 \times 10^{-1}$  | 12. $6.3 \times 10^{-3}$   |
| 13. $5.83 \times 10^{-2}$ | 14. $8.075 \times 10^{-4}$ |
| 15. $1.1 \times 10^{-5}$  | 16. $7.3458 \times 10^7$   |

**Express each number in scientific notation.**

- |                    |               |
|--------------------|---------------|
| 17. 1,000,000      | 18. 17,400    |
| 19. 500            | 20. 803,000   |
| 21. 0.00027        | 22. 5300      |
| 23. 18             | 24. 0.125     |
| 25. 17,000,000,000 | 26. 0.01      |
| 27. 21,800         | 28. 2,450,000 |
| 29. 0.0054         | 30. 0.000099  |
| 31. 8,888,800      | 32. 0.00912   |

**Choose the greater number in each pair.**

- |  |  |
|--|--|
| 33. $8.8 \times 10^3$ , $9.1 \times 10^{-4}$ | 34. $5.01 \times 10^2$ , $5.02 \times 10^{-1}$ |
| 35. $6.4 \times 10^3$ , 900                  | 36. $1.9 \times 10^{-2}$ , 0.02                |
| 37. $2.2 \times 10^{-3}$ , $2.1 \times 10^2$ | 38. $8.4 \times 10^2$ , 839                    |

**5-1 Skills Practice*****Writing Fractions as Decimals***

Write each fraction or mixed number as a decimal. Use a bar to show a repeating decimal.

1.  $\frac{3}{4}$

2.  $\frac{2}{5}$

3.  $\frac{5}{10}$

4.  $\frac{5}{5}$

5.  $\frac{13}{100}$

6.  $\frac{4}{5}$

7.  $\frac{7}{10}$

8.  $\frac{7}{8}$

9.  $\frac{1}{4}$

10.  $\frac{7}{50}$

11.  $-\frac{3}{10}$

12.  $\frac{1}{11}$

13.  $1\frac{1}{8}$

14.  $\frac{1}{12}$

15.  $\frac{7}{30}$

16.  $\frac{1}{15}$

17.  $4\frac{7}{11}$

18.  $-10\frac{5}{9}$

19.  $-2\frac{3}{5}$

20.  $6\frac{1}{6}$

Replace each  $\bullet$  with  $<$ ,  $>$ , or  $=$  to make a true sentence.

21.  $\frac{1}{8} \bullet 0.12$

22.  $\frac{2}{3} \bullet 0.7$

23.  $-2\frac{3}{10} \bullet -2.3$

24.  $0.395 \bullet \frac{2}{5}$

25.  $0.1 \bullet \frac{1}{11}$

26.  $0.\overline{16} \bullet \frac{1}{6}$

27.  $\frac{3}{5} \bullet \frac{3}{4}$

28.  $-3\frac{1}{4} \bullet -3.25$

29. Order  $\frac{9}{11}$ , 0.99, and  $\frac{9}{10}$  from least to greatest.

30. Order 0.5,  $\frac{4}{9}$ , and  $\frac{2}{5}$  from least to greatest.

## 5-2 Skills Practice

### *Rational Numbers*

Write each number as a fraction.

1. 13

2.  $1\frac{1}{4}$

3. 57

4. -25

5.  $-3\frac{4}{5}$

6.  $6\frac{5}{8}$

7. -1

8.  $2\frac{2}{9}$

Write each decimal as a fraction or mixed number in simplest form.

9. 0.6

10. 0.25

11.  $0.\overline{4}$

12.  $-1.\overline{1}$

13. 0.11

14. 2.8

15. 7.03

16. -2.12

17.  $3.\overline{2}$

18. 1.125

19. 8.65

20. 16.7

21. 0.16

22. 4.06

23.  $-5.\overline{8}$

24.  $0.\overline{24}$

25. Write 85 hundredths as a fraction in simplest form.

26. Write 9 and 250 thousandths as a mixed number in simplest form.

Identify all sets to which each number belongs (W = whole numbers, I = integers, Q = rational numbers).

27. 16

28. -2.54

29.  $\frac{9}{3}$

30.  $0.\overline{95}$

31. -4

32. 2.2020020002...

**5-3 Skills Practice*****Multiplying Rational Numbers***

Find each product. Write in simplest form.

1.  $\frac{1}{3} \cdot \left(-\frac{1}{4}\right)$

2.  $-\frac{2}{5} \cdot \frac{6}{7}$

3.  $\frac{2}{7} \cdot \frac{3}{11}$

4.  $\frac{3}{13} \cdot \frac{2}{5}$

5.  $\frac{2}{9} \cdot \frac{3}{5}$

6.  $\frac{3}{11} \cdot \frac{5}{9}$

7.  $-\frac{1}{4} \cdot \frac{4}{9}$

8.  $\frac{3}{5} \cdot \frac{15}{18}$

9.  $\frac{5}{16} \cdot 4$

10.  $5\frac{1}{2} \cdot \frac{2}{11}$

11.  $-12\frac{2}{3} \cdot 7\frac{1}{2}$

12.  $-\frac{5}{36} \cdot \left(-\frac{9}{25}\right)$

13.  $8\frac{4}{5} \cdot 2\frac{5}{10}$

14.  $3\frac{1}{3} \cdot 9\frac{3}{4}$

15.  $\frac{3}{a} \cdot \frac{b}{5}$

16.  $\frac{2x}{5} \cdot \frac{3}{x}$

17.  $\frac{9m}{n} \cdot \frac{2n}{3}$

18.  $\frac{3s}{t^2} \cdot \frac{t}{9s^2}$

19.  $\frac{ab}{c} \cdot \frac{c^2}{b}$

20.  $\frac{x}{y} \cdot \frac{2x}{4}$

21.  $\frac{r^2s}{t} \cdot \frac{3t^2}{rs^3}$

22.  $\frac{ab^3}{9} \cdot \frac{b}{a^2}$

23.  $\frac{m^4n^2p}{4} \cdot \frac{8p^2}{m^4n}$

24.  $\frac{3xy}{5} \cdot \frac{15xyz^2}{y^2}$

**MEASUREMENT Complete.**

25. \_\_\_\_\_?\_\_\_\_\_ quarts =  $6\frac{1}{4}$  gallons

26.  $9\frac{3}{5}$  minutes = \_\_\_\_\_?\_\_\_\_\_ seconds

27. \_\_\_\_\_?\_\_\_\_\_ days =  $17\frac{1}{2}$  weeks

**5-4 Skills Practice*****Dividing Rational Numbers*****Find the multiplicative inverse of each number.**

1.  $\frac{7}{12}$

2.  $-\frac{3}{10}$

3.  $\frac{1}{8}$

4.  $-64$

5.  $8\frac{1}{3}$

6.  $-10\frac{2}{3}$

7.  $-6\frac{5}{6}$

8.  $1\frac{1}{8}$

**Find each quotient. Write in simplest form.**

9.  $\frac{1}{3} \div \frac{7}{18}$

10.  $-\frac{2}{5} \div \frac{4}{25}$

11.  $-5 \div \frac{1}{7}$

12.  $\frac{2}{3} \div \frac{2}{3}$

13.  $\frac{4}{5} \div \left(-\frac{1}{15}\right)$

14.  $\frac{19}{20} \div \frac{4}{5}$

15.  $3 \div \frac{1}{4}$

16.  $-15 \div \frac{1}{2}$

17.  $\frac{4}{9} \div \frac{5}{12}$

18.  $\frac{7}{10} \div \left(-\frac{4}{5}\right)$

19.  $\frac{7}{12} \div \left(-1\frac{1}{6}\right)$

20.  $1\frac{5}{8} \div \frac{5}{8}$

21.  $12\frac{3}{5} \div 2\frac{7}{10}$

22.  $-\frac{3}{11} \div \frac{6}{22}$

23.  $\frac{1}{8} \div \frac{15}{16}$

24.  $-12\frac{4}{5} \div \left(-1\frac{1}{15}\right)$

25.  $1\frac{12}{13} \div \frac{25}{26}$

26.  $-7\frac{1}{3} \div 2\frac{1}{5}$

27.  $\frac{x}{6} \div \frac{x}{30}$

28.  $\frac{12}{5x} \div \frac{6}{2x}$

29.  $\frac{m}{16} \div \frac{mp}{7}$

30.  $\frac{3r}{s} \div \frac{4rs}{s^2}$

31.  $\frac{a}{b} \div \frac{5}{b}$

32.  $\frac{2a}{b} \div \frac{3a^2}{b^2}$

33.  $\frac{3}{5c} \div \frac{1}{10c}$

34.  $\frac{pq}{6} \div \frac{q}{8}$

35.  $\frac{x^2}{7} \div \frac{2x}{21}$

36.  $\frac{gh}{6} \div \frac{36}{h}$

37.  $\frac{3n}{2m} \div \frac{5n}{5m}$

38.  $\frac{4b}{c} \div \frac{5bc}{c}$



**5-5 Skills Practice*****Adding and Subtracting Like Fractions***

Find each sum or difference. Write in simplest form.

1.  $\frac{4}{15} + \frac{6}{15}$

2.  $\frac{7}{12} + \frac{11}{12}$

3.  $\frac{7}{10} + \frac{9}{10}$

4.  $\frac{20}{21} - \frac{2}{21}$

5.  $\frac{11}{12} - \frac{5}{12}$

6.  $\frac{5}{8} + \frac{7}{8}$

7.  $\frac{10}{11} + \frac{9}{11}$

8.  $\frac{17}{30} - \frac{7}{30}$

9.  $\frac{5}{6} + \frac{5}{6}$

10.  $4\frac{4}{5} + 3\frac{2}{5}$

11.  $20\frac{1}{25} + 1\frac{4}{25}$

12.  $5\frac{11}{15} + 3\frac{14}{15}$

13.  $26\frac{7}{12} + 11\frac{11}{12}$

14.  $20\frac{3}{4} - 3\frac{1}{4}$

15.  $25\frac{4}{5} - 3\frac{2}{5}$

16.  $\frac{10}{15} - \frac{13}{15}$

17.  $\frac{a}{6} + \frac{4a}{6}$

18.  $\frac{7c}{16} + \frac{7c}{16}$

19.  $\frac{25}{x} - \frac{17}{x}, x \neq 0$

20.  $1\frac{1}{2y} - 2\frac{1}{2y}$

21.  $\frac{7x}{9} - \frac{7x}{9}$

22.  $\frac{3m}{5} + \frac{8m}{5}$

Evaluate each expression if  $x = \frac{5}{8}$ ,  $y = 1\frac{3}{8}$ , and  $z = \frac{1}{8}$ .

23.  $x + y$

24.  $y - x$

25.  $x - z$

26.  $x + y + z$

**5-6 Skills Practice*****Least Common Multiple***

Find the least common multiple (LCM) of each pair of numbers or monomials.

1. 9, 12

2. 8, 10

3. 7, 21

4. 6, 10

5. 14, 35

6. 18, 24

7. 30, 12

8. 36, 42

9.  $5a$ ,  $3a^2$

10.  $8st$ ,  $5t$

11.  $rs$ ,  $s^2$

12.  $2b^2$ ,  $3ab$

Find the least common denominator (LCD) of each pair of fractions.

13.  $\frac{2}{3}$ ,  $\frac{3}{4}$

14.  $\frac{7}{20}$ ,  $\frac{8}{22}$

15.  $\frac{3}{10}$ ,  $\frac{7}{12}$

16.  $\frac{4}{17}$ ,  $\frac{23}{51}$

17.  $\frac{7}{9}$ ,  $\frac{5}{6}$

18.  $\frac{73}{100}$ ,  $\frac{73}{80}$

19.  $\frac{7}{48}$ ,  $\frac{25}{36}$

20.  $\frac{7}{3p}$ ,  $\frac{6}{2p}$

21.  $\frac{8}{d^2e}$ ,  $\frac{7}{9d^3}$

22.  $\frac{9}{5ab}$ ,  $\frac{7}{10c^2}$

Replace each  $\bullet$  with  $<$ ,  $>$ , or  $=$  to make a true sentence.

23.  $\frac{5}{6} \bullet \frac{5}{15}$

24.  $\frac{3}{4} \bullet \frac{9}{10}$

25.  $\frac{3}{5} \bullet \frac{4}{7}$

26.  $\frac{1}{8} \bullet \frac{4}{32}$

27.  $\frac{3}{9} \bullet \frac{5}{27}$

28.  $\frac{11}{16} \bullet \frac{22}{24}$

29.  $\frac{2}{9} \bullet \frac{3}{10}$

30.  $\frac{1}{6} \bullet \frac{4}{25}$

**5-7 Skills Practice*****Adding and Subtracting Unlike Fractions***

Find each sum or difference. Write in simplest form.

1.  $\frac{4}{7} + \frac{1}{3}$

2.  $\frac{2}{5} + \frac{3}{4}$

3.  $\frac{1}{2} + \left(-\frac{3}{10}\right)$

4.  $-\frac{5}{6} + \frac{7}{9}$

5.  $\frac{5}{12} + \frac{23}{24}$

6.  $\frac{10}{11} - \frac{1}{2}$

7.  $\frac{4}{5} - \left(-\frac{1}{3}\right)$

8.  $\frac{5}{6} - \frac{1}{12}$

9.  $\frac{19}{20} + \frac{1}{4}$

10.  $-\frac{9}{10} - \frac{1}{3}$

11.  $\frac{13}{15} - \frac{2}{3}$

12.  $\frac{7}{10} + \frac{1}{5}$

13.  $-\frac{3}{8} + \frac{1}{6}$

14.  $\frac{33}{100} - \frac{1}{10}$

15.  $\frac{11}{12} - \left(-\frac{7}{8}\right)$

16.  $\frac{4}{5} - \frac{1}{8}$

17.  $5\frac{2}{3} + 2\frac{1}{6}$

18.  $1\frac{7}{8} + 3\frac{1}{3}$

19.  $3\frac{2}{3} - \frac{1}{9}$

20.  $23\frac{3}{4} - 12\frac{5}{16}$

21.  $-7\frac{1}{2} + \frac{3}{4}$

22.  $2\frac{2}{3} + 1\frac{1}{4}$

23.  $-12\frac{1}{2} - 17\frac{1}{2}$

24.  $12\frac{1}{3} - \frac{3}{5}$

25.  $11\frac{15}{16} - 7\frac{1}{2}$

26.  $8\frac{5}{9} + 1\frac{1}{6}$

27.  $-7\frac{1}{2} + 3\frac{1}{7}$

28.  $60\frac{1}{2} + \left(-37\frac{1}{6}\right)$

29.  $8\frac{2}{3} - 3\frac{1}{3}$

30.  $-21\frac{7}{16} + 13\frac{1}{4}$

**5-8 Skills Practice****Solving Equations With Rational Numbers**

Solve each equation. Check your solution.

1.  $b + 2.7 = 3.5$

2.  $c - 9.8 = 3.6$

3.  $\frac{1}{6} + d = \frac{3}{4}$

4.  $x - \frac{8}{9} = 1$

5.  $-3.2 + y = 8.4$

6.  $3.5x = 14$

7.  $\frac{2}{7} + p = -\frac{3}{4}$

8.  $2x = -9.0$

9.  $\frac{x}{6} = 10.2$

10.  $g - 8.95 = 11.45$

11.  $h + \frac{6}{11} = \frac{3}{22}$

12.  $a + 6.11 = 8.45$

13.  $\frac{2}{3}m = \frac{20}{27}$

14.  $w - 3\frac{2}{3} = 4\frac{5}{6}$

15.  $0.22f = 13.2$

16.  $\frac{x}{0.5} = 18$

17.  $3.14r = 7.85$

18.  $\frac{7}{8}s = \frac{4}{5}$

19.  $-3.9 + r = -8.5$

20.  $9.8a = 20.58$

21.  $\frac{9}{100} + h = \frac{1}{10}$

22.  $\frac{m}{8} = \frac{15}{24}$

23.  $\frac{4}{5}t = 8$

24.  $10 = \frac{3}{4}s$

25.  $-0.5v = -9$

26.  $3x = 1\frac{1}{2}$

27.  $v - 1\frac{1}{3} = 1\frac{4}{5}$

28.  $3\frac{7}{8} + q = 1\frac{1}{2}$

29.  $\frac{5}{11}d = 35$

30.  $4\frac{2}{3} = \frac{1}{3}y$

**5-9**

**Skills Practice**

**Measures of Central Tendency**

Find the mean, median, and mode for each set of data. If necessary, round to the nearest tenth.

1. 6, 3, 3, 12, 13, 15, 7

2. 1, 1, 0, 2, 1, 1, 0, 0, 1

3. 202, 195, 219, 220

4. 2.5, 4.0, 8.7, 3.3, 3.3, 5.2

5. 21, 23, 39, 44, 27, 25, 28, 30

6. 87, 85, 87, 87, 87

Find the mean, median, and mode for each set of data. If necessary, round to the nearest tenth.

7.

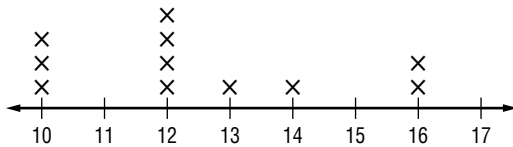

8.

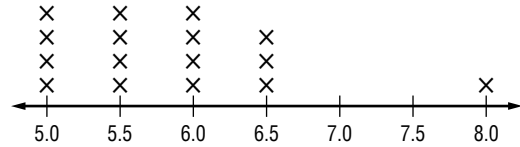

9. **TEMPERATURE** The average daily temperature by month for one year in Denver, Colorado, is given below. Find the mean, median, and mode for temperature.

Month	Jan	Feb	Mar	Apr	May	June	July	Aug	Sept	Oct	Nov	Dec
Temp. (°F)	43°	47°	51°	61°	71°	82°	88°	86°	78°	67°	52°	46°

Source: *The Universal Almanac*

**6-1 Skills Practice****Ratios and Rates**

Express each ratio as a fraction in simplest form.

1. 8 pencils out of 12 pens
2. 42 textbooks to 28 students
3. 27 rooms to 48 windows
4. 15 angel fish to 75 fish
5. 75 cats to 100 dogs
6. 6 aces out of 24 serves
7. 3 gallons to 15 quarts
8. 30 feet to 11 yards

Express each ratio as a unit rate. Round to the nearest tenth or nearest cent, if necessary.

9. \$9 for 6 cans of soup
10. \$39 for a case of 75 bananas
11. 108 miles in 6 days
12. 51 meters in 8 seconds
13. 21 new pairs of sneakers in 7 years
14. 52 feet for 8 costumes
15. 40 sneezes in 20 minutes
16. \$2702 from 28 people

Convert each rate using dimensional analysis.

17.  $12 \text{ m/min} = \underline{\quad ? \quad} \text{ cm/s}$
18.  $8 \text{ qt/min} = \underline{\quad ? \quad} \text{ gal/h}$
19.  $44 \text{ yd/s} = \underline{\quad ? \quad} \text{ mi/h}$
20.  $10 \text{ c/min} = \underline{\quad ? \quad} \text{ qt/h}$
21.  $32 \text{ ft/h} = \underline{\quad ? \quad} \text{ yd/day}$
22.  $56 \text{ mi/h} = \underline{\quad ? \quad} \text{ ft/min}$
23.  $40 \text{ cm/s} = \underline{\quad ? \quad} \text{ m/min}$
24.  $180 \text{ in./min} = \underline{\quad ? \quad} \text{ yd/h}$

**6-2 Skills Practice*****Proportional and Nonproportional Relationships***

Determine whether the set of numbers in each table are proportional.

1. 

<b>Number of Socks</b>	1	2	3	4
<b>Cost</b>	\$2	\$4	\$6	\$6

2. 

<b>Number of Guests</b>	2	4	6	8
<b>Cookies</b>	4	8	12	16

3. 

<b>Days</b>	1	3	5	6
<b>Pages Read</b>	100	300	550	600

4. 

<b>Cups of Flour</b>	2	4	8	10
<b>Loaves of Bread</b>	1	2	4	5

For Exercises 5–6, complete each table. Determine whether the pattern forms a proportion.

5. **BABY-SITTING** Aliya earns \$7 per hour baby-sitting her neighbors.

<b>Hours</b>	1				
<b>Earnings</b>	\$7				

6. **PIZZA** Antonio's Pizzeria charges \$10 for a large pizza, plus \$1.50 for each additional topping.

<b>Number of Toppings</b>	1				
<b>Cost</b>					

7. **TRAVELING** On a cross-country road trip, a family drives 240 miles each day. Write and solve an equation to determine how far the family has traveled after 4 days.

**6-3 Skills Practice****Using Proportions**

Determine whether each pair of ratios forms a proportion.

1.  $\frac{1}{5}, \frac{4}{20}$

2.  $\frac{3}{8}, \frac{12}{32}$

3.  $\frac{4}{5}, \frac{9}{10}$

4.  $\frac{12}{20}, \frac{18}{30}$

5.  $\frac{3}{4}, \frac{27}{36}$

6.  $\frac{10}{18}, \frac{2}{9}$

7.  $\frac{4}{9}, \frac{2}{3}$

8.  $\frac{15}{18}, \frac{10}{12}$

9.  $\frac{15}{24}, \frac{3}{8}$

10.  $\frac{36}{72}, \frac{50}{100}$

11.  $\frac{10}{8.4}, \frac{5}{4.2}$

12.  $\frac{12}{4.8}, \frac{9}{3.2}$

**ALGEBRA** Solve each proportion.

13.  $\frac{8}{4} = \frac{t}{8}$

14.  $\frac{n}{9} = \frac{4}{18}$

15.  $\frac{3}{v} = \frac{12}{32}$

16.  $\frac{25}{60} = \frac{s}{12}$

17.  $\frac{21}{28} = \frac{3}{w}$

18.  $\frac{c}{12} = \frac{5}{6}$

19.  $\frac{4}{r} = \frac{5}{20}$

20.  $\frac{12}{18} = \frac{m}{81}$

21.  $\frac{2}{9} = \frac{6}{k}$

22.  $\frac{h}{35} = \frac{3}{7}$

23.  $\frac{3}{16} = \frac{u}{40}$

24.  $\frac{6}{a} = \frac{1}{3}$

25.  $\frac{e}{9.5} = \frac{6.4}{7.6}$

26.  $\frac{2.7}{3.0} = \frac{3.6}{x}$

27.  $\frac{1.68}{w} = \frac{7}{12}$



**6-4 Skills Practice*****Scale Drawings and Models***

On a set of architectural drawings for a new school building, the scale is  $\frac{1}{4}$  inch = 2 feet. Find the missing lengths of the rooms.

	Room	Drawing Length	Actual Length
1.	Lobby		16 feet
2.	Principal's Office	1.25 inches	
3.	Library		20 feet
4.	School Room	3 inches	
5.	Science Lab	1.5 inches	
6.	Cafeteria		48 feet
7.	Music Room	4 inches	
8.	Gymnasium	13 inches	
9.	Auditorium		56 feet
10.	Teachers' Lounge	1.75 inches	

- Refer to Exercises 1–10. What is the scale factor?
- What is the scale factor if the scale is 10 inches = 1 foot?
- STRUCTURES** A barn is 40 feet wide by 100 feet long. Make a scale drawing of the barn that has a scale of  $\frac{1}{2}$  inch = 10 feet.
- MAPS** On a map, the key indicates that 1 centimeter equals 3.5 meters. A road is shown on this map that runs for 30 centimeters. How long is this road?

**6-5 Skills Practice*****Fractions, Decimals, and Percents***

Express each percent as a fraction or mixed number in simplest form and as a decimal.

1. 55%

2. 2%

3.  $5\frac{1}{2}\%$

4. 30%

5. 300%

6. 12%

7. 50%

8. 90%

9. 85%

10. 28.2%

11. 0.25%

12. 0.2%

13. 7.5%

14. 6%

15. 10%

16. 275%

Express each decimal or fraction as a percent. Round to the nearest tenth percent, if necessary.

17. 0.65

18. 0.772

19. 0.6

20. 3.45

21. 0.47

22. 0.01

23. 22.6

24. 0.79

25. 0.28

26. 0.355

27. 0.0015

28. 44

29.  $\frac{11}{20}$

30.  $\frac{1}{4}$

31.  $\frac{5}{8}$

32.  $\frac{7}{5}$

33.  $\frac{23}{4}$

34.  $\frac{4}{5}$

35.  $\frac{3}{25}$

36.  $\frac{7}{3}$

37.  $2\frac{3}{10}$

38.  $\frac{1}{6}$

39.  $\frac{300}{630}$

40.  $\frac{9}{10}$

**6-6 Skills Practice*****Using the Percent Proportion***

Use the percent proportion to solve each problem. Round to the nearest tenth.

1. 64 is what percent of 200?
2. What percent of 12 is 9?
3. 2 is what percent of 80?
4. What percent of 42 is 32?
5. 10 is what percent of 60?
6. What percent of 30 is 6?
7. 15 is what percent of 24?
8. What percent of 36 is 9?
9. 28 is what percent of 42?
10. What percent of 72 is 21?
11. 8 is 40% of what number?
12. 16 is 5% of what number?
13. 25 is 80% of what number?
14. 0.84 is 28% of what number?
15. 71 is 10% of what number?
16. 52 is 97% of what number?
17. 39 is 17% of what number?
18. 12 is 4% of what number?
19. 48.5 is 7% of what number?
20. What is 10.6% of 11?
21. What is 15% of 98.4?
22. What is 0.5% of 75?
23. What is 4% of 512.5?
24. What is 50% of 1?
25. What is 25% of 12?
26. What is 12% of 25?
27. What is 90% of 50?
28. What is 50% of 90?

**6-7 Skills Practice*****Finding Percents Mentally*****Find the percent of each number mentally.**

1. 10% of 582

2. 50% of 86

3. 40% of 1500

4. 20% of 75

5. 15% of 20

6. 80% of 45

7. 30% of 120

8. 75% of 44

9. 5% of 40

10.  $33\frac{1}{3}\%$  of 99

11. 60% of 450

12.  $37\frac{1}{2}\%$  of 56

13. 25% of 480

14. 300% of 5

15. 150% of 82

16.  $66\frac{2}{3}\%$  of 210

17. 125% of 800

18. 175% of 400

**Estimate.**

19. 28% of 19

20. 55% of 32

21. 87% of 158

22. 35% of 544

23. 42% of 495

24. 19% of 319

25. 65% of 73

26. 8% of 224

27. 83% of 9

28. 17% of 331

29. 78% of 14

30. 12% of 879

31.  $\frac{1}{3}\%$  of 941

32.  $\frac{1}{2}\%$  of 376

33.  $\frac{1}{5}\%$  of 2052

34. 164% of 318

35. 247% of 192

36. 508% of 1073

**6-8 Skills Practice*****Using Percent Equations***

Solve each problem using the percent equation.

1. What is 5% of 80?
2. What is 10% of 100?
3. What is 58% of 35?
4. What is 32% of 150?
5. What is 91% of 3800?
6. Find 25% of 68.
7. Find 80% of 75.
8. Find 75% of 80.
9. Find 1.5% of 8400.
10. Find 33.5% of 22.
11. 23 is what percent of 115?
12. 27 is what percent of 75?
13. 80 is what percent of 160?
14. 85 is what percent of 500?
15. 48 is what percent of 30?
16. 321.3 is what percent of 918?
17. 0.6 is what percent of 2?
18. 126 is what percent of 140?
19. 21 is what percent of 1050?
20. 78 is what percent of 40?
21. 29 is 50% of what number?
22. 9 is 45% of what number?
23. 16 is 4% of what number?
24. 336 is 48% of what number?
25. 52 is 25% of what number?
26. 99 is 90% of what number?
27. 343 is 70% of what number?
28. 57 is 1% of what number?
29. 193.6 is 32% of what number?
30. 87.1 is 67% of what number?

**6-9 Skills Practice*****Percent of Change***

State whether each change is a *percent of increase* or a *percent of decrease*. Then find the percent of change. Round to the nearest tenth, if necessary.

1. from 12 m to 18 m
2. from 27 days to 30 days
3. from \$48.50 to \$38.80
4. from 25 lb to 12 lb
5. from 10 mm to 3 mm
6. from \$875 to \$1000
7. from \$18.10 to \$22.50
8. from 32 people to 3040 people
9. from 28 stray cats to 5 stray cats
10. from 12 words to 90 words
11. from 47 mph to 35 mph
12. from 8 computers to 15 computers
13. from 34 workers to 28 workers
14. from 8056 snowflakes to 6381 snowflakes
15. from 201 sales to 148 sales
16. from 153 balls to 380 balls
17. from 5 miles to 8 miles
18. from 850 singers to 715 singers
19. from 9 horses to 11 horses
20. from 900 CDs to 1100 CDs
21. from 14 cheerleaders to 12 cheerleaders
22. from 140 members to 120 members
23. from \$200 to \$210
24. from \$210 to \$200
25. from 300 s to 8 s
26. from 8 s to 300 s

**6-10 Skills Practice*****Using Sampling to Predict***

Identify each sample as *biased* or *unbiased* and describe its type. Explain your reasoning.

- To determine how many students have pets, all students in one classroom are surveyed.
- To determine the number of students who plan on attending the Valentine's Day dance, 20 students are randomly selected from each grade level.
- To determine whether customers are satisfied with their meals, a restaurant collects comment cards that are voluntarily filled out by customers.
- To determine the most popular color of car, the color of every 12th car that crosses an intersection is recorded.
- To determine the most popular major league baseball team among its readers, a sports magazine polled a random selection of its readers.

- 6. ANALYZE TABLES** The student council would like to sell pizza slices during home basketball games as a fund-raiser. During a home game with 250 people in attendance, they surveyed every 10th spectator to enter the gym about their favorite pizza toppings. Their results are shown in the table. Is this sampling method valid? If so, how many pepperoni pizzas should be ordered if they order 25 pizzas? Explain your reasoning.

Topping	Number
Pepperoni	10
Veggies	8
Cheese	7

# 7-1

## Skills Practice

### Functions

Determine whether each relation is a function. Explain.

1.  $\{(3, -8), (3, 2), (6, -1), (2, 2)\}$

2.  $\{(0, 1), (-4, -3), (-3, 6), (3, 6)\}$

3.  $\{(-6, 3), (2, -2), (0, 8), (1, 1)\}$

4.  $\{(1, 8), (-6, 21), (-11, 21), (-3, 11), (0, 21)\}$

5.

<b>x</b>	1	-3	8	-8	20
<b>y</b>	2	6	6	5	11

6.

<b>x</b>	4	11	8	-13	-4
<b>y</b>	2	-4	1	2	20

7.

<b>x</b>	-1.2	1.1	1.7	-1.2	1.0
<b>y</b>	2.8	2.3	-2.4	2.3	2.6

8.

<b>x</b>	7	0	-6	1	-11
<b>y</b>	-1	4	8	8	14

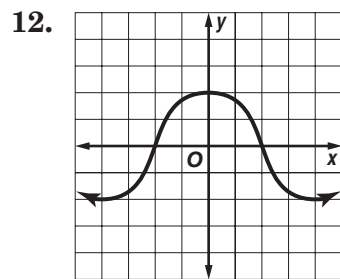
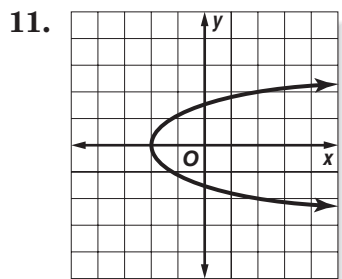
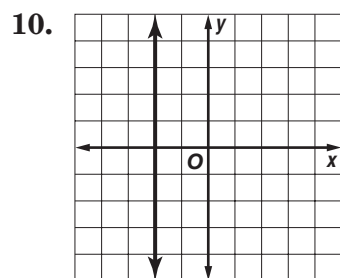
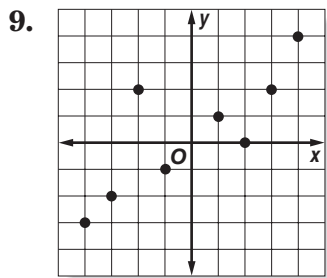

Copyright © Glencoe/McGraw-Hill, a division of The McGraw-Hill Companies, Inc.

Lesson 7-1



# 7-2

## Skills Practice

### Representing Linear Functions

Find four solutions of each equation. Write the solutions as ordered pairs.

1.  $y = 8x - 4$

2.  $y = -x + 12$

3.  $4x - 4y = 24$

4.  $x - y = -15$

5.  $y = 7x - 6$

6.  $y = -3x + 8$

7.  $y = 12$

8.  $4x - 2y = 0$

9.  $4x - y = 4$

Graph each equation by plotting ordered pairs.

10.  $y = 3x - 2$

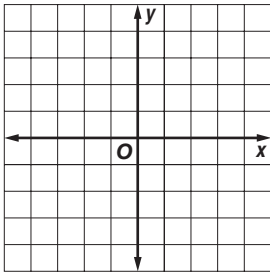

11.  $y = -x + 3$

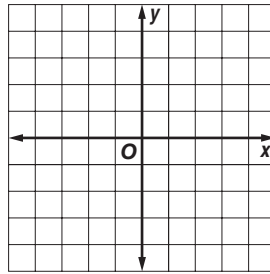

12.  $y = -\frac{1}{2}x + \frac{3}{2}$

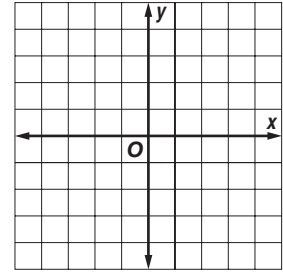

13.  $y = -2x - 5$

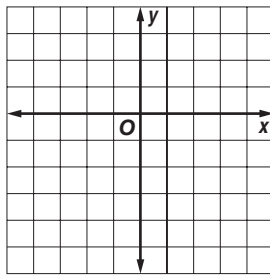

14.  $y = 4x - 8$

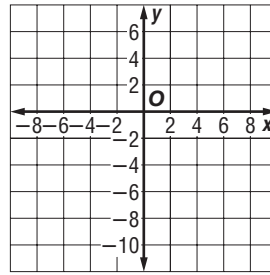

15.  $y = \frac{2}{3}x - 2$

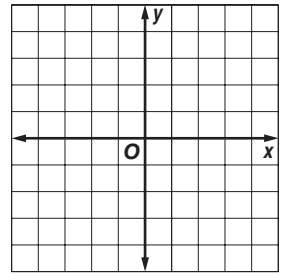

16.  $y = -5x$

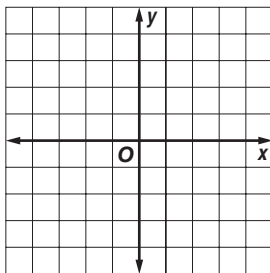

17.  $y = -2x + 6$

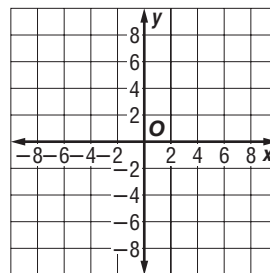

18.  $y = 5x + 1$

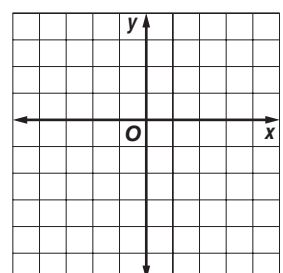

**7-3**

**Skills Practice**

**Rate of Change**

Find the rate of change for each linear function.

1.

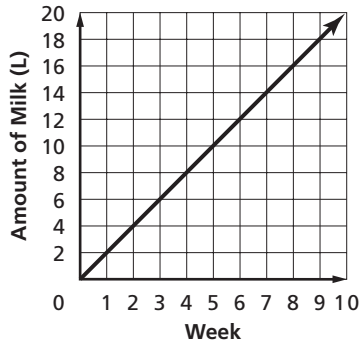

2.

Year	Salary (\$)
$x$	$y$
1	21,000
2	23,500
3	26,000
4	28,500

3.

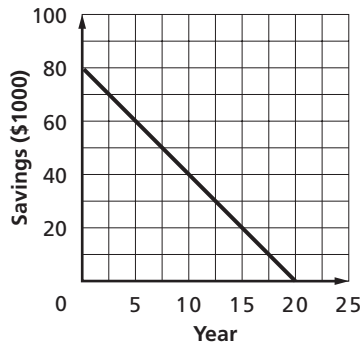

4.

Month	Number of Employees
$x$	$y$
0	0
2	22
4	44
6	66

5.

Time (min)	Temperature ( $^{\circ}\text{C}$ )
$x$	$y$
0	9
1	23
2	37
3	51
4	65

6.

**Price of Bulk Food**

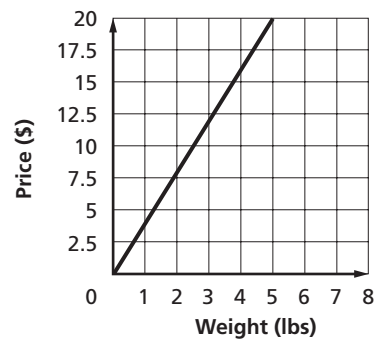

# 7-4 Skills Practice

## Constant Rate of Change and Direct Variation

Find the constant rate of change for each linear function and interpret its meaning.

1.

Gallons	Quarts
$x$	$y$
1	4
2	8
3	12
4	16

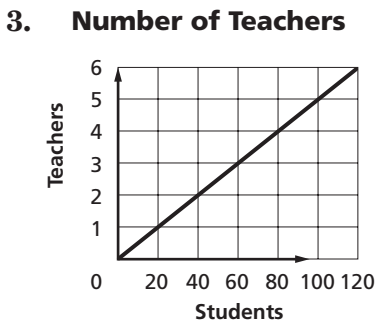
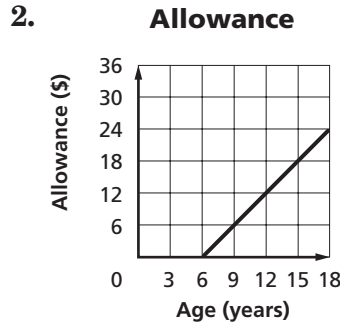

4.

Width (ft)	Height (in)
$x$	$y$
2	10
4	14
6	18
8	22

Determine whether a proportional linear relationship exists between the two quantities shown in each of the functions indicated. Explain your reasoning.

5. Exercise 1
6. Exercise 2
7. Exercise 3
8. Exercise 4

# 7-5 Skills Practice

## Slope

Find the slope of each line.

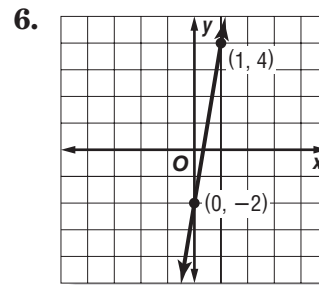
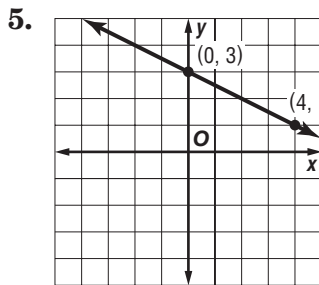
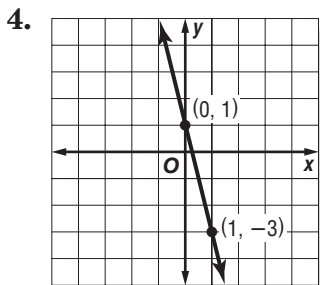
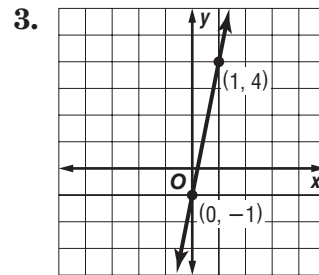
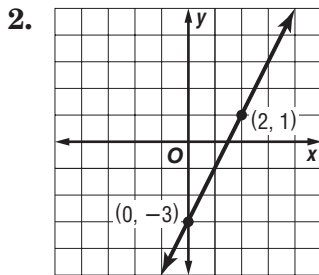
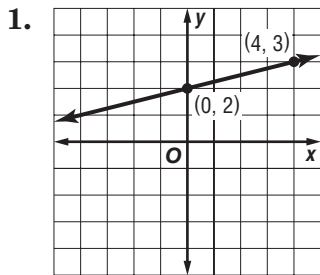

Find the slope of the line that passes through each pair of points.

7.  $A(1, -5), B(6, -7)$

8.  $C(7, -3), D(8, 1)$

9.  $E(7, 2), F(12, 6)$

10.  $G(8, -3), H(11, -2)$

11.  $J(5, -9), K(0, -12)$

12.  $L(-4, 6), M(5, 3)$

13.  $P(2, -2), Q(7, -1)$

14.  $R(-5, -2), S(-5, 3)$

15.  $T(5, -6), U(8, -12)$

16.  $P(10, -2), Q(3, -1)$

17.  $R(6, -5), S(7, 3)$

18.  $T(1, 8), U(7, 8)$

19. **CAMPING** A family camping in a national forest builds a temporary shelter with a tarp and a 4-foot pole. The bottom of the pole is even with the ground, and one corner is staked 5 feet from the bottom of the pole. What is the slope of the tarp from that corner to the top of the pole?

20. **ART** A rectangular painting on a gallery wall measures 7 meters high and 4 meters wide. What is the slope from the upper left corner to the lower right corner?

# 7-6 Skills Practice

## Slope-Intercept Form

State the slope and the  $y$ -intercept for the graph of each equation.

1.  $y = 12x - 4$                       2.  $y = \frac{1}{4}x + 3$                       3.  $3x - y = 6$

Given the slope and  $y$ -intercept, graph each line.

4. slope =  $-2$ ,  
 $y$ -intercept =  $2$                       5. slope =  $\frac{1}{2}$ ,  
 $y$ -intercept =  $4$                       6. slope =  $\frac{2}{3}$ ,  
 $y$ -intercept =  $-3$

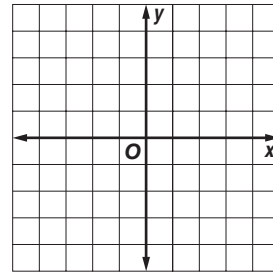
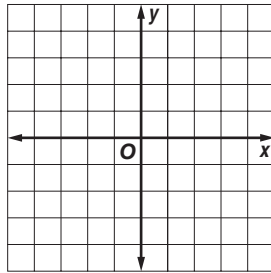
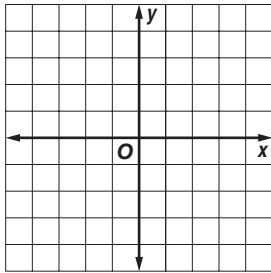

Graph each equation using the slope and  $y$ -intercept.

7.  $y = 5x - 1$                       8.  $y = \frac{1}{2}x + 2$                       9.  $y = -x + 2$

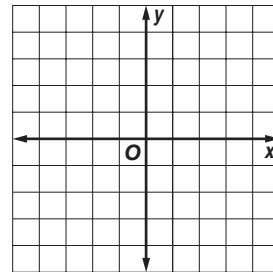
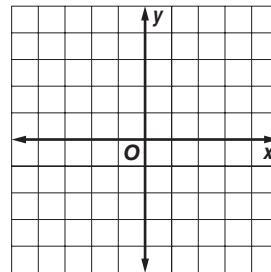
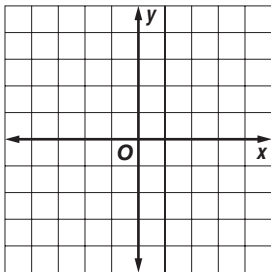

10.  $y = 2x + 2$                       11.  $y = -4x + 2$                       12.  $y = x - 3$

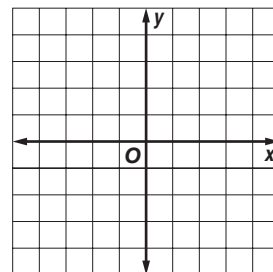
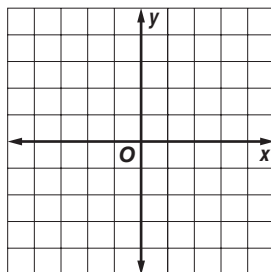
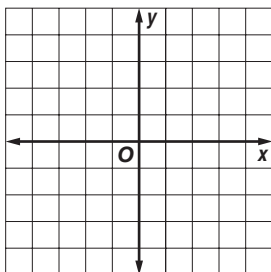

# 7-7 Skills Practice

## Writing Linear Functions

Write an equation in slope-intercept form for each line.

1. slope = 7,  
y-intercept = 2

2. slope = -5,  
y-intercept = -3

3. slope =  $\frac{3}{5}$ ,  
y-intercept = 6

4. slope = -6,  
y-intercept = 7

5. slope =  $\frac{2}{7}$ ,  
y-intercept = 1

6. slope =  $\frac{4}{3}$ ,  
y-intercept = -4

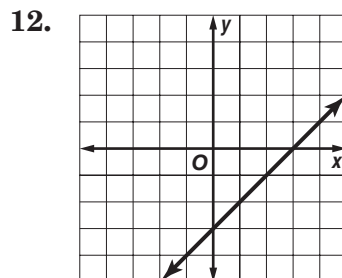
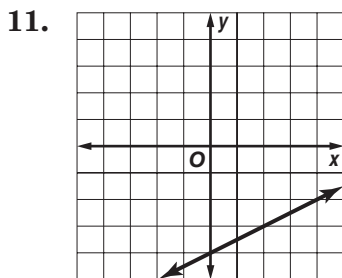
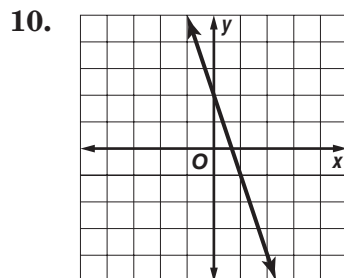
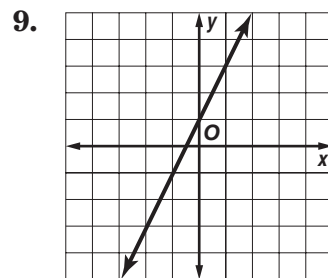
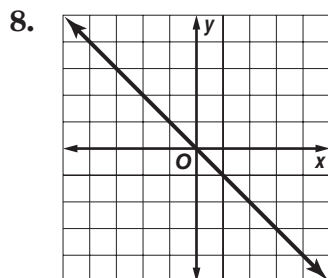
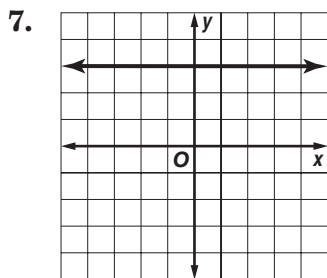

Write an equation in slope-intercept form for the line passing through each pair of points.

13. (9, -1) and (6, -2)

14. (12, 5) and (-4, 1)

15. (10, -6) and (-2, -6)

16. (4, 6) and (1, 3)

17. (6, 3) and (-6, 9)

18. (8, -4) and (-4, -1)

19. (5, 0) and (2, -3)

20. (12, -2) and (6, 2)

21. (-5, 10) and (3, -6)

# 7-8 Skills Practice

## Prediction Equations

**CONSTRUCTION** For Exercises 1 and 2, use the table that shows the average hourly wage of U.S. construction workers from 1980 to 2000.

Year	Average Hourly Earnings (\$)
1980	9.94
1985	12.32
1990	13.77
1995	15.09
2000	17.48

Source: U.S. Census Bureau

1. Make a scatter plot and draw a best-fit line.

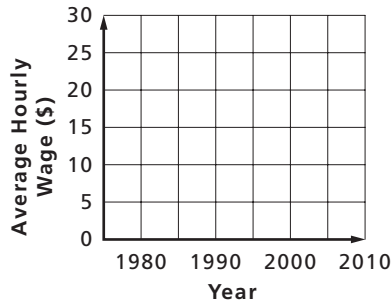

2. Use the best-fit line to predict the average hourly wage of construction workers in 2010.

**MINING** For Exercises 3 and 4, use the table that shows the number of persons employed in mining from 1980 to 2000.

Year	Employees (thousands)
1980	1027
1985	927
1990	709
1995	581
2000	475

Source: U.S. Census Bureau

3. Make a scatter plot and draw a best-fit line.

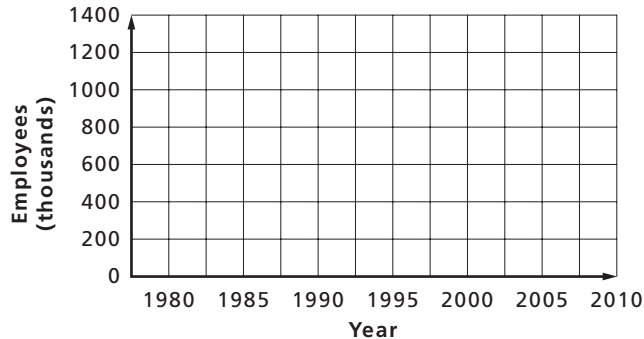

Source: U.S. Census Bureau

4. Write an equation for the best-fit line and use it to predict the number of persons employed in mining in 2010.

**8-1 Skills Practice*****Solving Equations with Variables on Each Side***

Solve each equation. Check your solution.

1.  $3x + 2 = 5x$

2.  $n - 12 = 3n$

3.  $2 - 3b = 7b + 12$

4.  $4d - 11 = 2d + 7$

5.  $2f + 3 = 11f - 24$

6.  $8y + 11 = 2y + 29$

7.  $5a = 45 + 2a$

8.  $17 - 3c = 4c + 3$

9.  $2a - 3 = 9a - 10$

10.  $5b = 21 + 4b$

11.  $9y - 27 = -2y + 6$

12.  $2n - 5 = 7n$

13.  $-s + 3 = 5s + 21$

14.  $7 - 4c = 3c + 35$

15.  $30 - 2n = 4n$

16.  $29 + 7d = 5d + 15$

17.  $16k - 23 = 6k - 13$

18.  $w - 20 = 6w$

19.  $33g + 28 = 25g - 12$

20.  $6h - 34 = -6h + 14$

21.  $3t + 17 = t - 3$

22.  $11j = 6j - 15$

23.  $c - 2 = 3c + 14$

24.  $28x - 7 = 26x + 5$

25.  $5m - 6 = 8m + 9$

26.  $-4p - 7 = 5p + 11$

27.  $-10 + 3f = 5f + 6$

28.  $4f + 6 = 8f - 14$

29.  $-7n - 16 = 4n + 17$

30.  $5d = 9d - 18$

Define a variable and write an equation to find each number. Then solve.

31. Three times a number equals 40 more than five times the number. What is the number?

32. A number equals four less than three times the number. What is the number?

33. Eight times a number equals 24 more than two times the number. What is the number?



**8-2 Skills Practice****Solving Equations with Grouping Symbols**

Solve each equation. Check your solution.

1.  $2(g - 7) = 16$

2.  $5(x + 2) = 30$

3.  $3(2d + 7) = 39$

4.  $4(a - 2) = 3(a + 4)$

5.  $3(f + 2) + 9 = 13 + 5f$

6.  $2(x - 4) = 3(1 + x)$

7.  $2n + 5 = 4(n + 2) - n$

8.  $4(x + 3) = x$

9.  $2(c - 3) = 76$

10.  $7(x - 2) = 5(x + 2)$

11.  $2(6x + 1) = 4(x - 5) - 2$

12.  $4(2b - 6) + 11 = 8b - 13$

13.  $6 + 6(2t - 1) = 3 + 12t$

14.  $9t - 21 = 3(t - 7) + 6t$

15.  $3(4k + 14) = 10k - 2(k - 7)$

Find the dimensions of each rectangle. The perimeter is given.

16.  $P = 380$  m

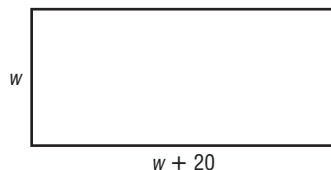

17.  $P = 640$  yd

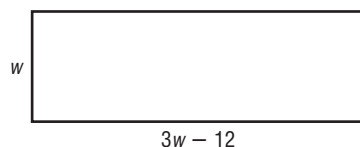

18.  $P = 220$  ft

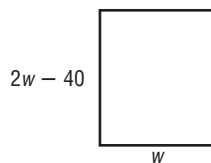

19.  $P = 380$  yd

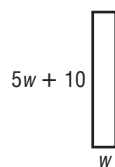

20.  $P = 300$  m

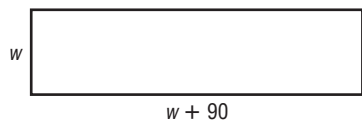

# 8-3

## Skills Practice

### Inequalities

Write an inequality for each sentence.

- More than 100,000 fans attended the opening football game at The Ohio State University.
- Her earnings at \$16 per hour were no more than \$96.
- A savings account decreased by \$50 is now less than \$740.
- A number increased by 7 is at least 45.



For the given value, state whether each inequality is true or false.

- |                              |                                |
|------------------------------|--------------------------------|
| 5. $\frac{18}{c} < 9, c = 2$ | 6. $\frac{x}{5} \geq 3, x = 5$ |
| 7. $6k \geq 42, k = 7$       | 8. $10 - x < 3, x = 7$         |
| 9. $11 + n < 32, n = 4$      | 10. $9 + c > 19, c = 10$       |

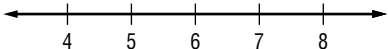
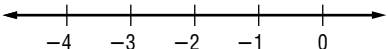
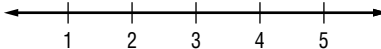
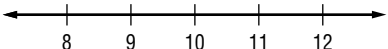
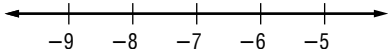
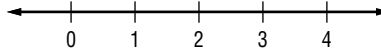
Graph each inequality on a number line.

11. $a < 6$ 	12. $t \geq -2$ 	13. $d \leq 3$ 
14. $b \geq 10$ 	15. $x \geq -7$ 	16. $x > 2$ 

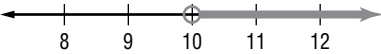
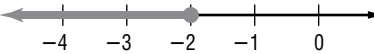
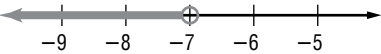
Write the inequality for each graph.

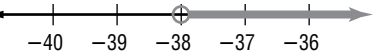
17. 	18. 
19. 	20. 
21. 	22. 

Copyright © Glencoe/McGraw-Hill, a division of The McGraw-Hill Companies, Inc.

Lesson 8-3

**8-4 Skills Practice****Solving Inequalities by Adding or Subtracting**

Solve each inequality. Check your solution.

1.  $p + 9 > 13$

2.  $t + 7 < -4$

3.  $-12 \geq 7 + x$

4.  $f + (-7) \leq 9$

5.  $5 > -3 + y$

6.  $r + 7 \leq -3$

7.  $b - 15 > 11$

8.  $z + (-4) < -8$

9.  $j - 4 \leq -10$

10.  $-5 > h - 3$

11.  $13 > w - (-14)$

12.  $g - 7 > -4$

13.  $-15 \leq d + (-2)$

14.  $2 + c \leq -8$

15.  $15 > c + 3$

16.  $j + 9 \leq -10$

Solve each inequality. Then graph the solution on a number line.

17.  $n + 6 < 7$

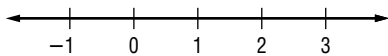

18.  $-4 + z \geq 3$

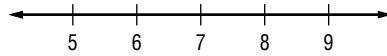

19.  $p + (-3) > -6$

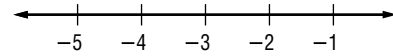

20.  $-11 \geq x + 8$

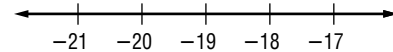

21.  $15 \leq m - (-2)$

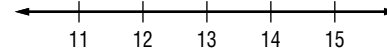

22.  $k + 7 \geq -9$

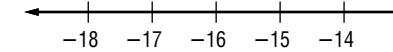

23.  $-5 < 2 + a$

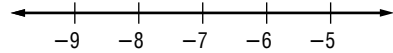

24.  $t - 7 > 5$

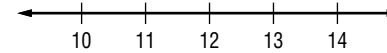

25.  $-2 + z \geq 7$

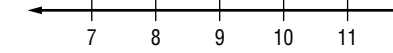

26.  $p - (-7) > -8$

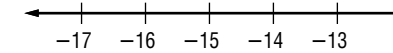

27.  $-6 \leq m + 2$

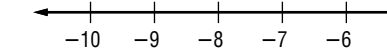

28.  $-2 < w - 5$

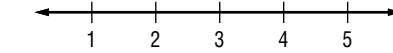

29. **SHOPPING** Chantal would like to buy a new pair of running shoes. Shoes that she likes start at \$85. If she has already saved \$62, what is the least amount she must still save?

**8-5 Skills Practice*****Solving Inequalities by Multiplying or Dividing***

Solve each inequality and check your solution. Then graph the solution on a number line.

1.  $-8x > 16$

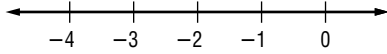

2.  $7y < -35$

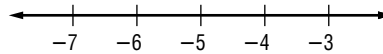

3.  $12a \geq -24$

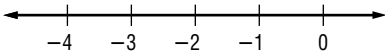

4.  $-12 \leq 4a$

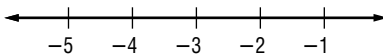

5.  $-6z < -18$

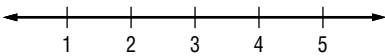

6.  $14 > -2k$

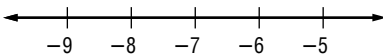

7.  $5 > \frac{x}{-2}$

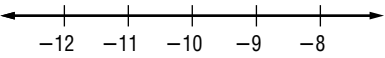

8.  $\frac{r}{-3} \leq -4$

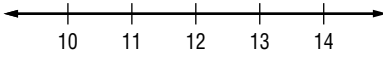

9.  $-10t \geq 200$

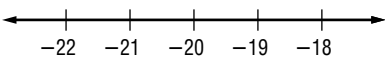

10.  $\frac{y}{7} < 2$

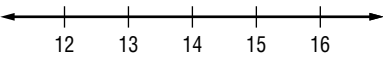

11.  $\frac{-1}{2}x \leq -6$

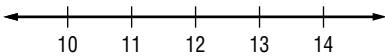

12.  $\frac{b}{-3} \leq 6$

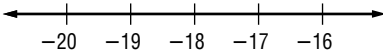

**13. TRAVEL** To get to the beach for vacation, Cheng's family must drive at least 660 miles on the first day. They are traveling at a constant speed of 60 miles per hour.

a. Write an inequality to represent how long the family should drive on the first day.

b. How many hours should the family drive?

**14. EARNINGS** Jess receives \$180 for every garage he paints over the summer. He wants to save at least \$1620 for college.

a. Write an inequality to represent how many garages Jess should paint over the summer.

b. How many garages should Jess paint?

**8-6 Skills Practice****Solving Multi-Step Inequalities**

Solve each inequality and check your solution. Graph the solution on a number line.

1.  $3x + 9 < 18$

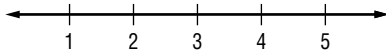

3.  $4x - 3 < 2 - x$

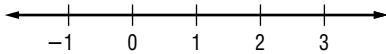

5.  $11 + 2b \leq 3(2 - b)$

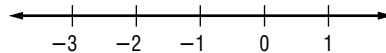

7.  $\frac{1}{2}(8 - x) > 6$

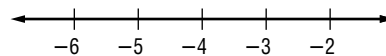

9.  $y - 3 < 5y + 1$

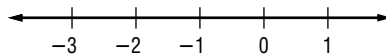

11.  $\frac{1}{3}(x - 6) < 2$

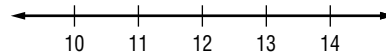

13.  $-2(3 + t) < -8$

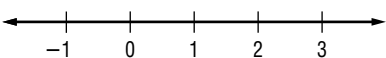

2.  $5 + 2c < -9$

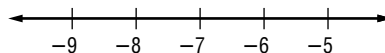

4.  $3(n + 2) < 24$

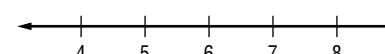

6.  $\frac{m}{3} + 5 \geq 2$

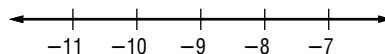

8.  $\frac{c}{4} + 7 \geq 5$

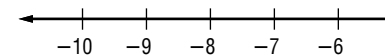

10.  $20 - 2n > 26$

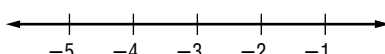

12.  $5 - 2k \leq 15$

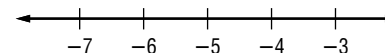

14.  $\frac{n}{4} - 9 > 5$

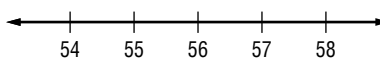

15. Two times a number less 4 is greater than the same number plus 6. For what number or numbers is this true?

16. One-half of the sum of a number and 4 is less than 14. What is the number?

17. **FISHING** Benjamin wants to go fishing on the lake. A boat rents for \$12 per hour and a rod and reel rent for \$20 per day. If he wants to spend no more than \$80, how many hours can he spend fishing in the boat?18. **ENTERTAINING** Deena is inviting 10 friends to a party. If she wants to spend no more than \$120 on her guests, and dinner for each guest costs \$8, what is the most she can spend on party favors for each person?

**9-1 Skills Practice****Squares and Square Roots****Find each square root, if possible.**

1.  $\sqrt{1}$

2.  $\sqrt{9}$

3.  $\sqrt{25}$

4.  $\sqrt{49}$

5.  $\sqrt{64}$

6.  $\sqrt{169}$

7.  $-\sqrt{36}$

8.  $\sqrt{-81}$

9.  $-\sqrt{64}$

10.  $-\sqrt{169}$

11.  $\sqrt{-196}$

12.  $-\sqrt{121}$

13.  $\sqrt{225}$

14.  $\sqrt{441}$

15.  $\sqrt{625}$

16.  $\pm\sqrt{289}$

17.  $\pm\sqrt{324}$

18.  $\pm\sqrt{8100}$

19.  $\sqrt{2.25}$

20.  $\sqrt{0.16}$

21.  $\sqrt{3.24}$

**Use a calculator to find each square root to the nearest tenth.**

22.  $\sqrt{31}$

23.  $\sqrt{40}$

24.  $\sqrt{94}$

25.  $\sqrt{132}$

26.  $-\sqrt{68}$

27.  $-\sqrt{247}$

28.  $\sqrt{-521}$

29.  $-\sqrt{314}$

30.  $-\sqrt{902}$

31.  $-\sqrt{0.85}$

32.  $-\sqrt{2.45}$

33.  $-\sqrt{4.05}$

**Estimate each square root to the nearest whole number. Do not use a calculator.**

34.  $\sqrt{38}$

35.  $\sqrt{84}$

36.  $\sqrt{389}$

37.  $\sqrt{5}$

38.  $\sqrt{118}$

39.  $\sqrt{230}$

40.  $-\sqrt{83}$

41.  $-\sqrt{19}$

42.  $-\sqrt{119}$

43.  $\sqrt{9.3}$

44.  $\sqrt{27.5}$

45.  $\sqrt{78.1}$

**9-2 Skills Practice*****The Real Number System***

Name all of the sets of numbers to which each real number belongs. Let **N** = natural numbers, **W** = whole numbers, **Z** = integers, **Q** = rational numbers, and **I** = irrational numbers.

- |                     |                  |                    |
|---------------------|------------------|--------------------|
| 1. 12               | 2. 25            | 3. -5              |
| 4. $\frac{1}{8}$    | 5. $\frac{1}{9}$ | 6. 0.343434...     |
| 7. $\sqrt{31}$      | 8. $\sqrt{7}$    | 9. $\frac{25}{5}$  |
| 10. $-\frac{32}{4}$ | 11. 6.54         | 12. 24.6           |
| 13. 418             | 14. 0            | 15. 0.050050005... |

Determine whether each statement is *sometimes*, *always*, or *never* true.

16. A whole number is a rational number.
17. A rational number is a natural number.
18. A negative number is an integer.
19. Zero is a natural number.

Replace each  $\bullet$  with  $<$ ,  $>$ , or  $=$  to make a true statement.

- |                                     |                                  |
|-------------------------------------|----------------------------------|
| 20. $\sqrt{4} \bullet 2\frac{3}{7}$ | 21. $\sqrt{5} \bullet 2.1$       |
| 22. $-\sqrt{12} \bullet -3.5$       | 23. $\sqrt{104.04} \bullet 10.2$ |
| 24. $7.8 \bullet \sqrt{55}$         | 25. $15.1 \bullet \sqrt{231}$    |

Order each set of numbers from least to greatest.

26.  $5\frac{1}{3}, 5.3, \sqrt{28}, 2\frac{1}{4}$
27.  $\sqrt{53}, 7\frac{1}{4}, \frac{36}{5}, 7.27$
28.  $-9.35, -\sqrt{72.25}, -9\frac{2}{10}, -9$

**ALGEBRA** Solve each equation. Round to the nearest tenth, if necessary.

- |                  |                  |                    |
|------------------|------------------|--------------------|
| 29. $a^2 = 64$   | 30. $d^2 = 169$  | 31. $f^2 = 441$    |
| 32. $76 = g^2$   | 33. $115 = h^2$  | 34. $k^2 = 450$    |
| 35. $b^2 = 4.41$ | 36. $y^2 = 0.36$ | 37. $m^2 = 0.0025$ |

# 9-3 Skills Practice

## Triangles

Classify each angle as *acute*, *obtuse*, *right*, or *straight*.

1.  $\angle AHB$
2.  $\angle AHC$
3.  $\angle AHD$
4.  $\angle AHE$
5.  $\angle AHF$
6.  $\angle AHG$

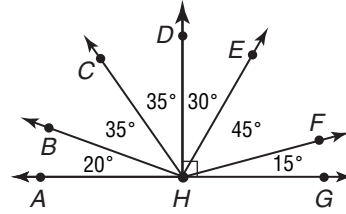

Find the value of  $x$  in each triangle. Then classify each triangle as *acute*, *right*, or *obtuse*.

- 7.
- 8.
- 9.
- 10.
- 11.
- 12.

Classify each dashed triangle by its angles and by its sides.

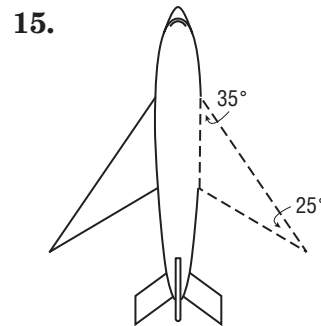
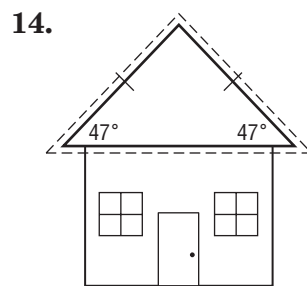
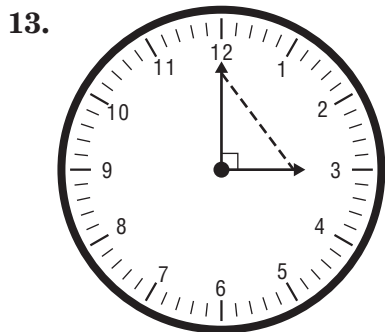



**9-4 Skills Practice*****The Pythagorean Theorem***

Find the length of the hypotenuse in each right triangle. Round to the nearest tenth, if necessary.

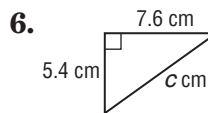
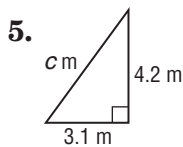
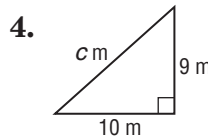
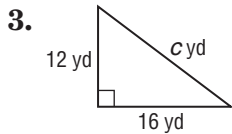
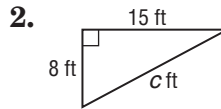
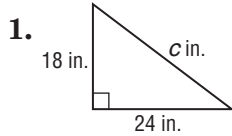

If  $c$  is the measure of the hypotenuse, find each missing measure. Round to the nearest tenth, if necessary.

7.  $a = ?$ ,  $b = 24$ ,  $c = 26$

8.  $a = 16$ ,  $b = ?$ ,  $c = 34$

9.  $a = 24$ ,  $b = ?$ ,  $c = 40$

10.  $a = 5$ ,  $b = ?$ ,  $c = 7$

11.  $a = ?$ ,  $b = 32$ ,  $c = 39$

12.  $a = 21$ ,  $b = ?$ ,  $c = 48$

13.  $a = 18$ ,  $b = 29$ ,  $c = ?$

14.  $a = ?$ ,  $b = 36$ ,  $c = 49$

15.  $a = 8$ ,  $b = ?$ ,  $c = 12$

16.  $a = 14$ ,  $b = 21$ ,  $c = ?$

17.  $a = ?$ ,  $b = 30$ ,  $c = 40$

18.  $a = 4$ ,  $b = ?$ ,  $c = 7$

19.  $a = 13$ ,  $b = 18$ ,  $c = ?$

20.  $a = ?$ ,  $b = 55$ ,  $c = 75$

The lengths of three sides of a triangle are given. Determine whether each triangle is a right triangle.

21. 14 m, 5 m, 4 m

22. 3 in., 4 in., 5 in.

**9-5 Skills Practice****The Distance Formula**

Find the distance between each pair of points. Round to the nearest tenth, if necessary.

1.  $A(2, 4), B(1, 3)$
2.  $P(5, 10), Q(-1, 1)$
3.  $G(3, -1), H(5, 6)$
4.  $C(-2, -6), D(-7, 1)$
5.  $E(-6, 2), F(4, 1)$
6.  $J(-5, -3), K(4, -2)$
7.  $M(-5, -5), N(3, -4)$
8.  $V(4, 7), W(1, 6)$
9.  $X(4, 6), Y(-3, -7)$
10.  $R(0, 0), S(-1, -1)$
11.  $T(7, 3), U(-2, -2)$
12.  $A(6, 2), B(1, 3)$
13.  $V(2, -6), W(4, -7)$
14.  $C(6, 2), D(4, 7)$
15.  $X(7, 8), Y(-7, 1)$
16.  $E(7, 3), F(-1, 4)$
17.  $A(5, 10), B(-4, -3)$
18.  $G(-6, 2), H(2, 4)$

**GEOMETRY** Find the perimeter of each figure. Round to the nearest tenth.

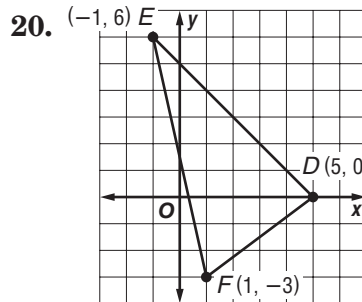
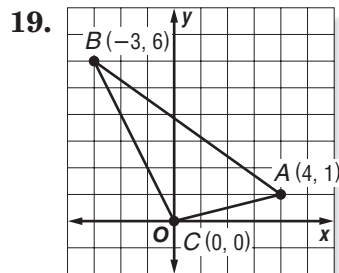

**GEOMETRY** The coordinates of the vertices of a triangle are given. Find the perimeter of each triangle. Round to the nearest tenth, if necessary.

21.  $J(4, 5), K(-2, 2)$ , and  $L(-4, 4)$
22.  $E(3, 5), F(4, 8)$ , and  $G(-1, 6)$
23.  $X(8, 1), Y(3, 3)$ , and  $Z(5, -3)$
24.  $A(-3, 5), B(-3, -1)$ , and  $C(7, -1)$

# 9-6 Skills Practice

## Similar Polygons and Indirect Measurement

In Exercises 1–10, the triangles are similar. Find each value of  $x$ .

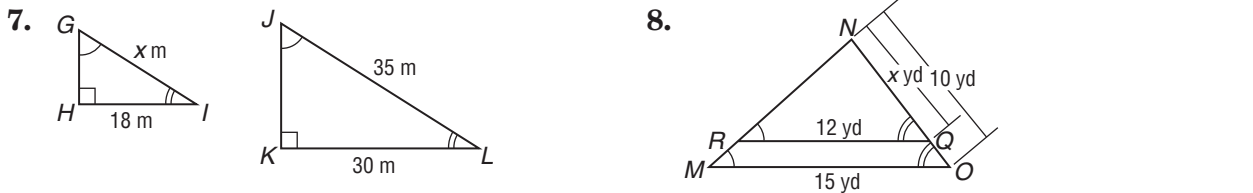
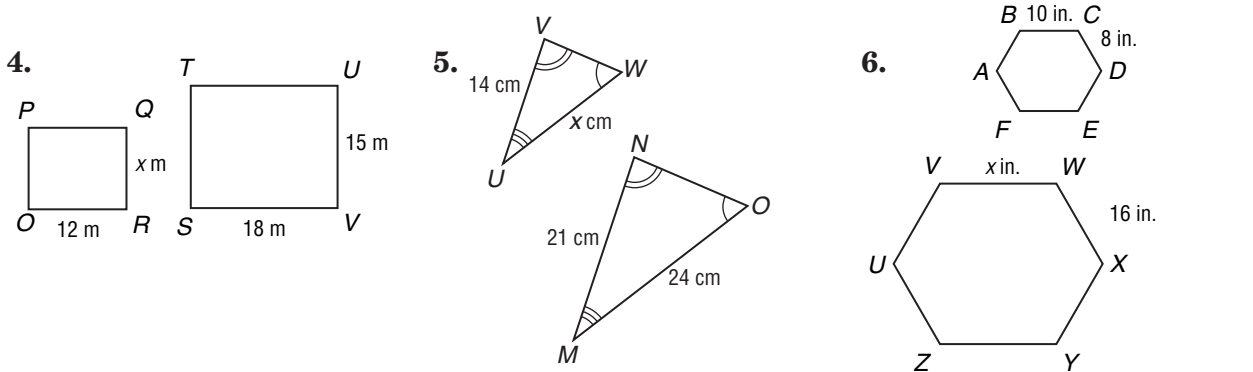
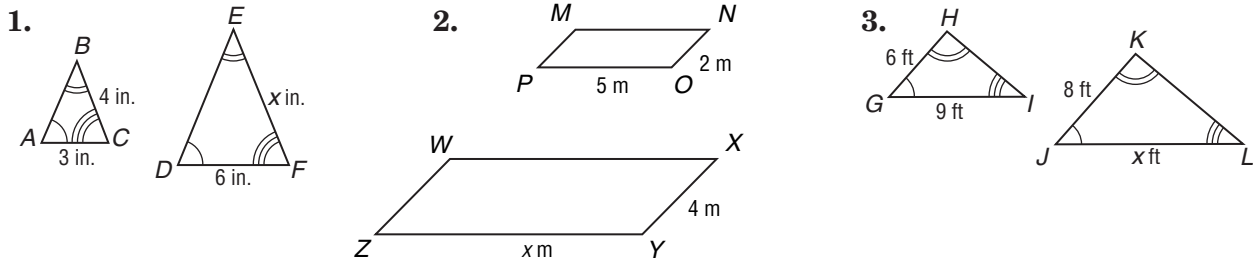

9. How far is the store from the bank?

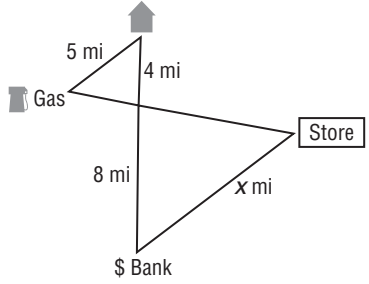

10. How far is the tree from the flagpole?

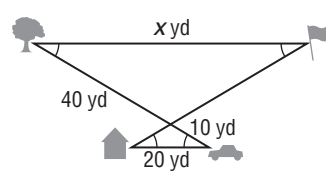

For Exercises 11 and 12, write a proportion. Then determine the missing measure.

11. **ANIMALS** At the same time a 12-foot adult elephant casts a 4.8-foot shadow, a baby elephant casts a 2-foot shadow. How tall is the baby elephant?

12. **AIRPORTS** If a 12-meter-tall airplane hangar casts a 18-meter shadow at the same time a parked jet casts a 6-meter shadow, how tall is the jet?

# 10-1 Skills Practice

## Line and Angle Relationships

In the figure at the right,  $c \parallel d$  and  $p$  is a transversal.

If  $m\angle 5 = 110^\circ$ , find the measure of each angle.

1.  $\angle 6$
2.  $\angle 8$
3.  $\angle 2$
4.  $\angle 4$

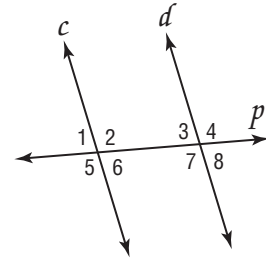

In the figure at the right,  $g \parallel k$  and  $r$  is a transversal.

If  $m\angle 7 = 60^\circ$ , find the measure of each angle.

5.  $\angle 4$
6.  $\angle 6$
7.  $\angle 5$
8.  $\angle 3$

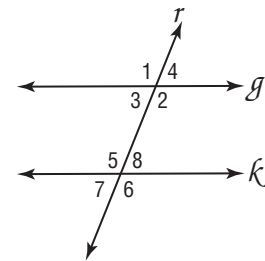

Find the value of  $x$  in each figure.

9.

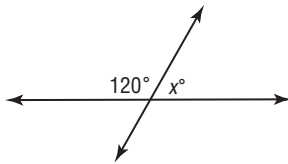

10.

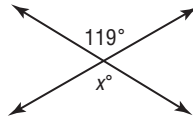

11.

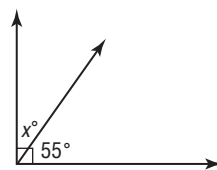

12.

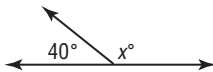

13.

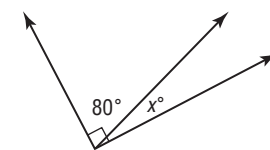

14.

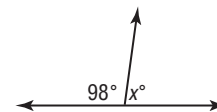

15.

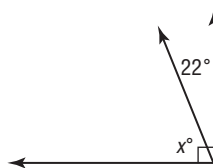

16.

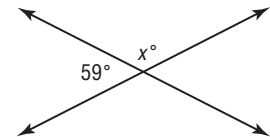

17.



18.

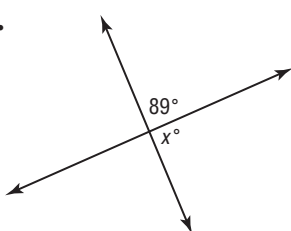

19.

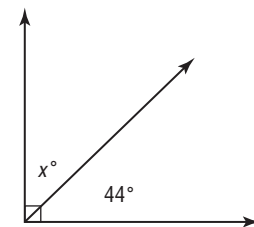

20.

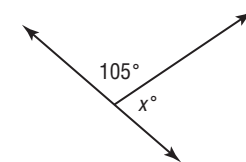

# 10-2 Skills Practice

## Congruent Triangles

For each pair of congruent triangles, name the corresponding parts. Then complete the congruence statement.

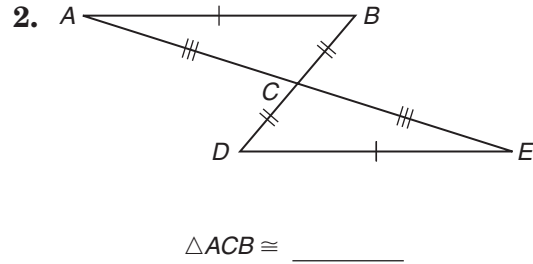
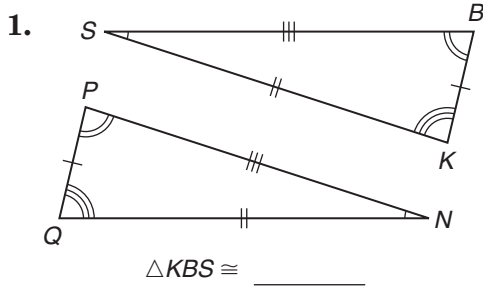

Complete each congruence statement if  $\triangle MRU \cong \triangle ACF$ .

3.  $\angle R \cong$  ?      4.  $\overline{CA} \cong$  ?      5.  $MU \cong$  ?      6.  $\angle A \cong$  ?

Complete each congruence statement if  $\triangle GLE \cong \triangle SPT$ .

7.  $\overline{EL} \cong$  ?      8.  $\angle S \cong$  ?      9.  $\angle E \cong$  ?      10.  $\overline{PS} \cong$  ?

Find the value of  $x$  for each pair of congruent triangles.

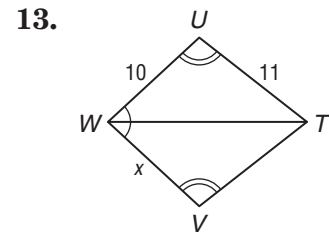
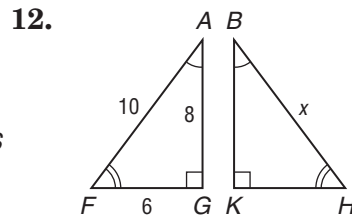
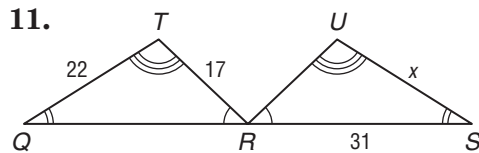

**ARCHITECTURE** For Exercises 14 and 15, use the diagram of the Eiffel Tower truss at the right and the fact that  $\triangle ACB \cong \triangle DFE$ .

14. Find the distance between A and B.

15. What is the measure of  $\angle B$ ?

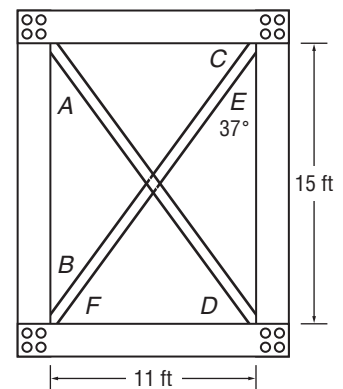

# 10-3 Skills Practice

## Transformations on the Coordinate Plane

Find the coordinates of the vertices of each figure after the given translation. Then graph the translation image.

1.  $(5, 2)$

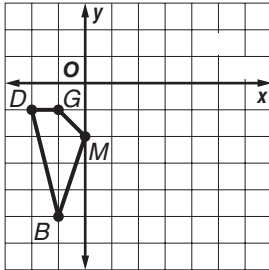

2.  $(-3, 4)$

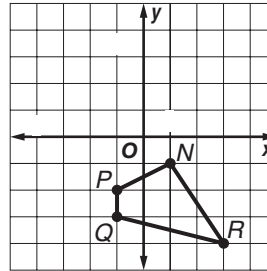

3.  $(-1, -5)$

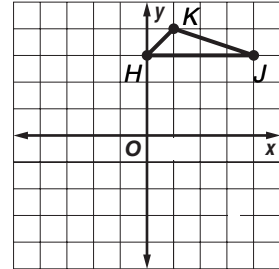

Find the coordinates of the vertices of each figure after a reflection over the given axis. Then graph the reflection image.

4.  $y$ -axis

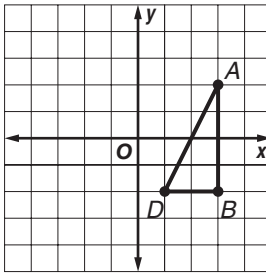

5.  $x$ -axis

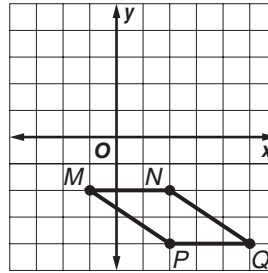

6.  $x$ -axis

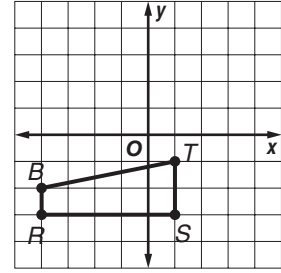

For Exercises 7–8, use the graph shown.

7. Graph the image of the figure after a dilation centered at the origin with a scale factor of 2.

8. Find the coordinates of the vertices after a dilation centered at the origin with a scale factor of  $\frac{1}{2}$ .

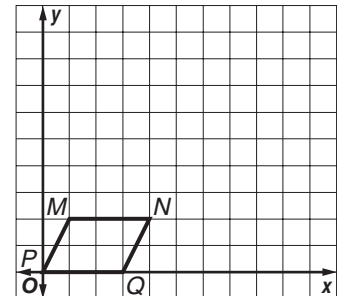

# 10-4 Skills Practice

## Quadrilaterals

**ALGEBRA** Find the value of  $x$ . Then find the missing angle measures.

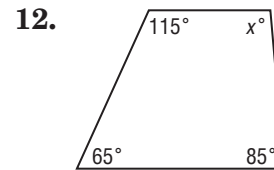
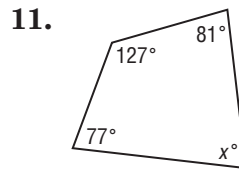
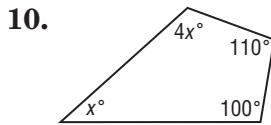
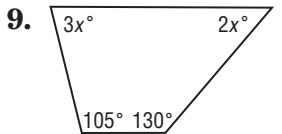
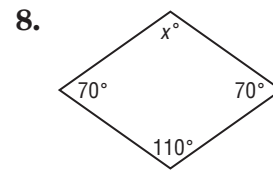
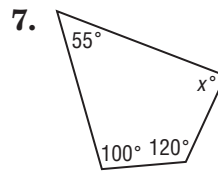
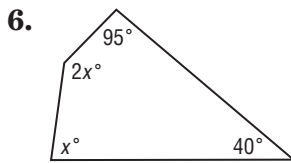
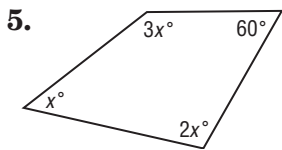
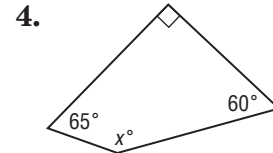
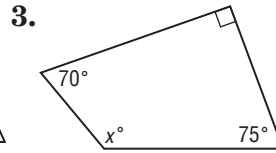
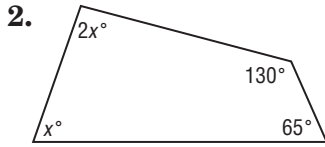
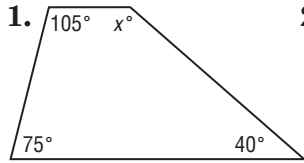

Classify each quadrilateral using the name that *best* describes it.

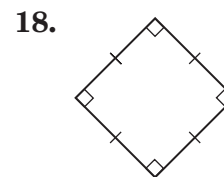
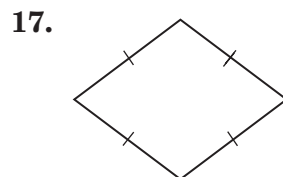
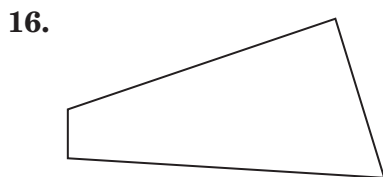
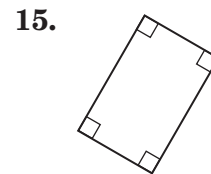
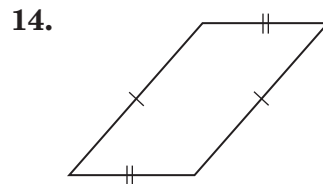
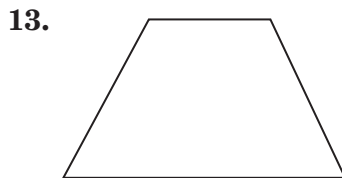

Tell whether each statement is *sometimes*, *always*, or *never* true.

- 19. A rhombus is a square.
- 20. A square is a parallelogram.
- 21. A parallelogram is a square.

# 10-5 Skills Practice

## Polygons

Classify each polygon. Then determine whether it appears to be *regular* or *not regular*.

1.

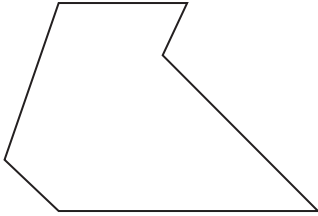

2.

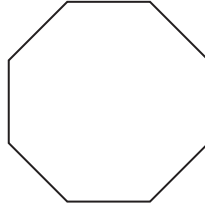

3.

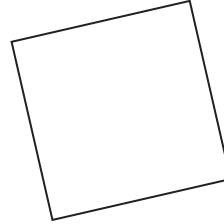

4.

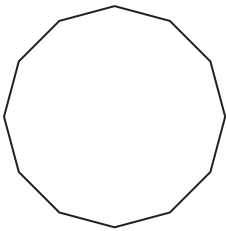

5.

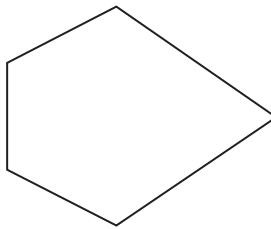

6.

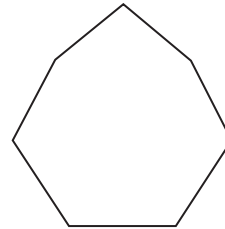

Find the sum of the measures of the interior angles of each polygon.

7. pentagon

8. 20-gon

9. nonagon

10. decagon

Find the measure of an interior angle of each polygon.

11. regular hexagon

12. regular heptagon

13. regular quadrilateral

14. regular octagon

15. regular pentagon

16. regular 100-gon

**TESSELLATIONS** For Exercises 17 and 18, identify the polygons used to create each tessellation.

17.

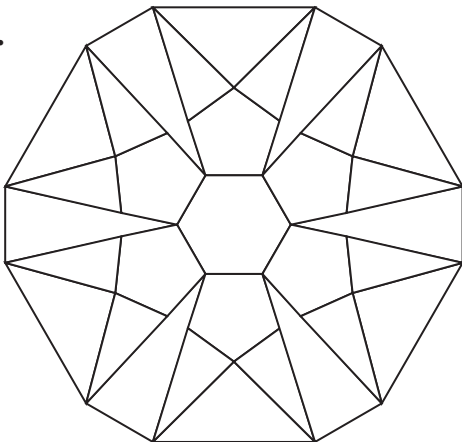

18.

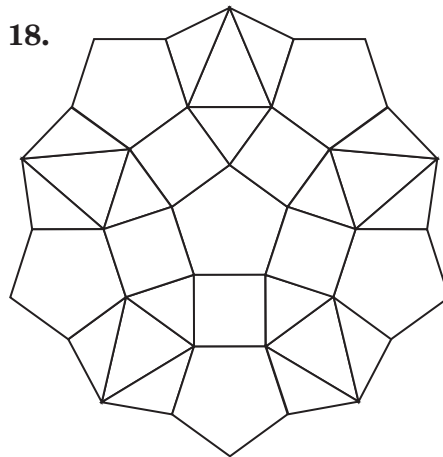



# 10-6 Skills Practice

## Area: Parallelograms, Triangles, and Trapezoids

Find the area of each figure.

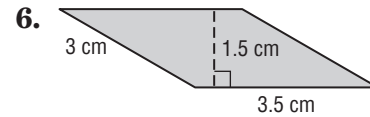
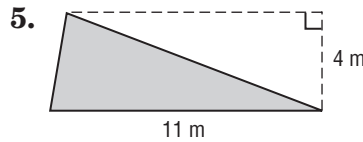
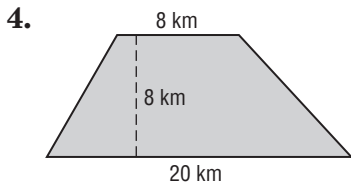
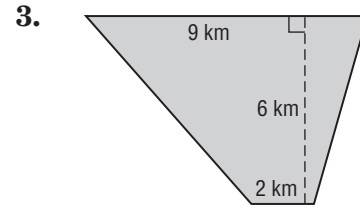
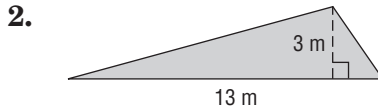
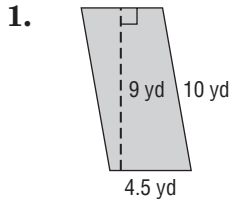

Find the area of each figure described.

- 7. triangle: base, 11 m; height, 3 m
- 8. parallelogram: base, 8 cm; height, 9.5 cm
- 9. trapezoid: height, 12 yd; bases, 4 yd, 7 yd
- 10. parallelogram: base, 6.5 ft; height, 12 ft
- 11. trapezoid: height, 10 m; bases, 3 m, 6 m
- 12. triangle: base, 7 km; height, 5 km

Find the area of each figure.

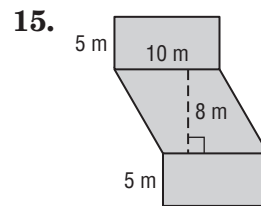
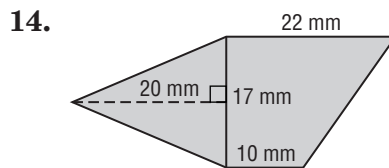
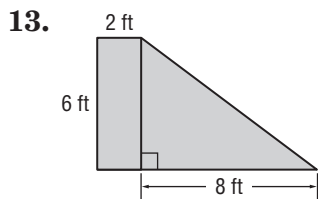

**GEOGRAPHY** For Exercises 16–18, use the approximate measurements to estimate the area of each state.

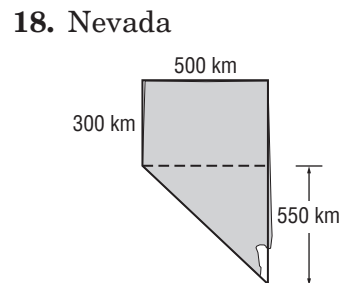
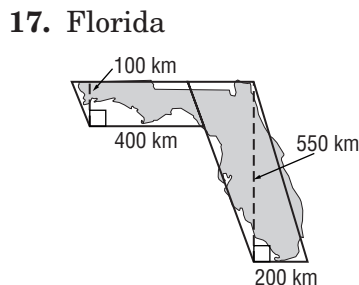
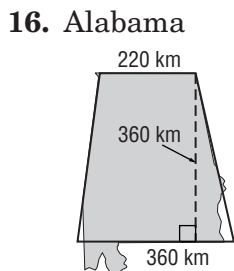

# 10-7 Skills Practice

## Circumference and Area: Circles

Find the circumference and area of each circle. Round to the nearest tenth.

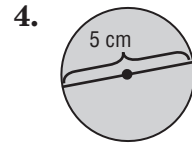
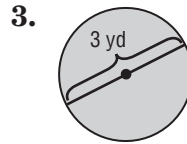
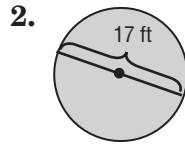
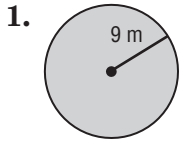

- 5. The radius is 7 kilometers.
- 6. The diameter is 20 centimeters.
- 7. The diameter is 8.5 meters.
- 8. The radius is 11 yards.
- 9. The diameter is  $6\frac{2}{5}$  feet.
- 10. The radius is 25 inches.

Match each circle described in the column on the left with its corresponding measurement in the column on the right.

- |                        |                                  |
|------------------------|----------------------------------|
| 11. diameter: 6 units  | a. area: 19.6 units <sup>2</sup> |
| 12. radius: 9 units    | b. circumference: 40.8 units     |
| 13. diameter: 13 units | c. area: 28.3 units <sup>2</sup> |
| 14. radius: 2.5 units  | d. circumference: 56.5 units     |
15. **SPORTS** A basketball goal is 18 inches in diameter. A basketball has a diameter of about 9.6 inches. What is the difference in area between the goal and the center cross-section of a basketball?
16. **CULTURE** The Navajo and Pueblo Indians create large, circular sand paintings as part of traditional healing ceremonies. How much more area does a sand painting with a 20-foot diameter have compared with one with a 5-foot diameter?
17. **SPORT** In bowling, the distance from the foul line to the headpin is 60 feet. A bowling ball has a radius of about 4.3 inches. How many times must the ball rotate in order to strike the headpin?

Find the area of each figure. Round to the nearest tenth.

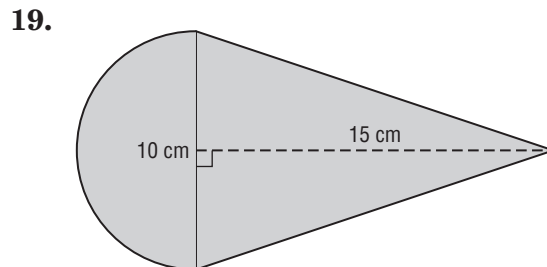
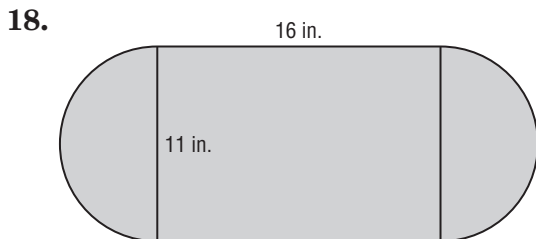

# 10-8 Skills Practice

## Area: Composite Figures

Find the area of each figure. Round to the nearest tenth.

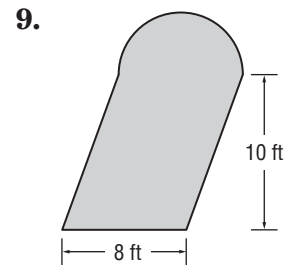
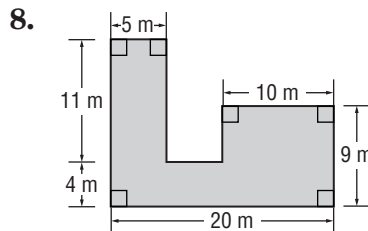
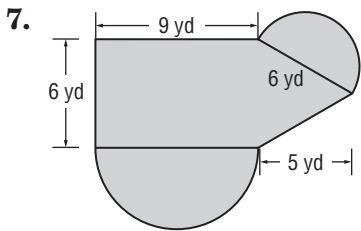
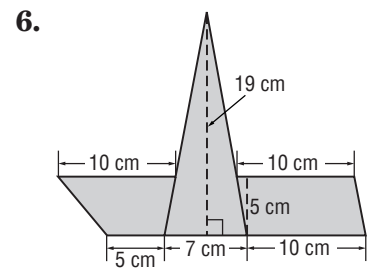
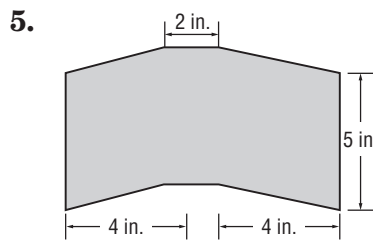
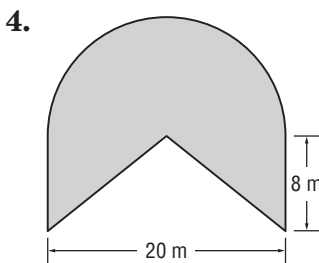
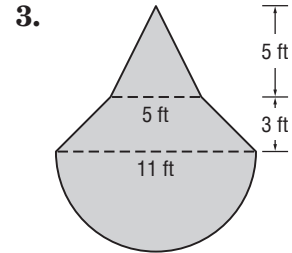
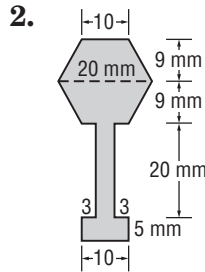
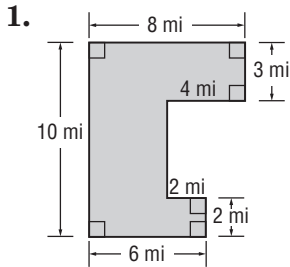

10. What is the area of a figure formed using a square with sides of 12 kilometers and three circles with diameters of 12 kilometers each?

Find the area of each shaded area. Round to the nearest tenth, if necessary. (*Hint: Find the total area and subtract the non-shaded area.*)

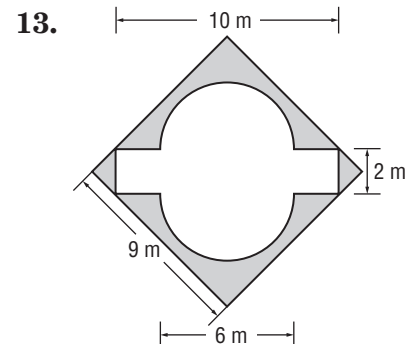
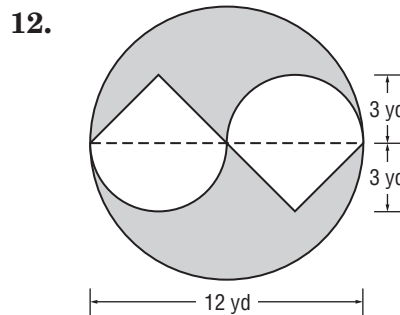
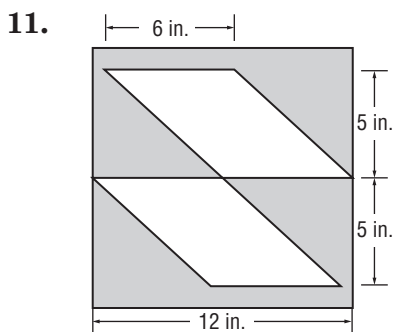

# 11-1 Skills Practice

## Three-Dimensional Figures

Identify each solid. Name the bases, faces, edges, and vertices.

1.

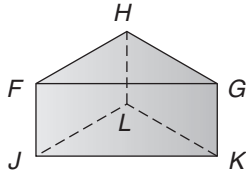

2.

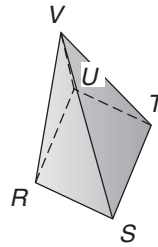

3.

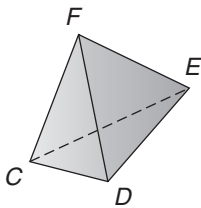

4.

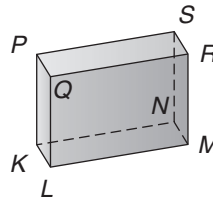

For Exercises 5–8, use the rectangular prism below.

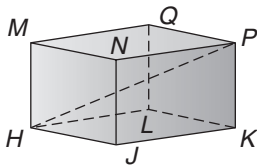

5. Identify a diagonal.
6. Name four segments skew to  $\overline{LQ}$ .
7. State whether  $\overline{NP}$  and  $\overline{HM}$  are *parallel*, *skew*, or *intersecting*.
8. Name a segment that does *not* intersect plane  $KLQP$ .

# 11-2 Skills Practice

## Volume: Prisms and Cylinders

Find the volume of each solid shown or described. If necessary, round to the nearest tenth.

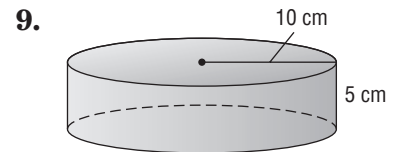
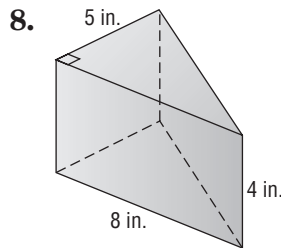
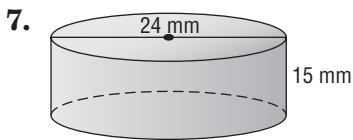
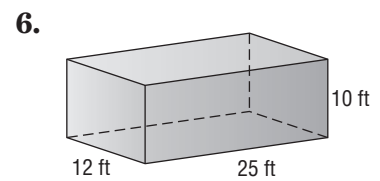
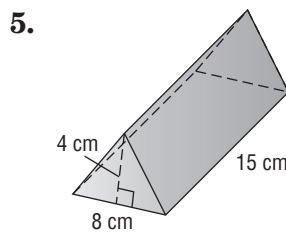
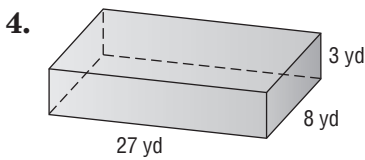
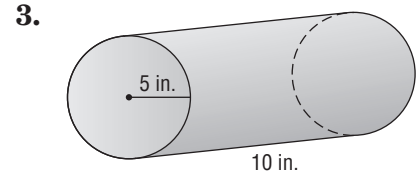
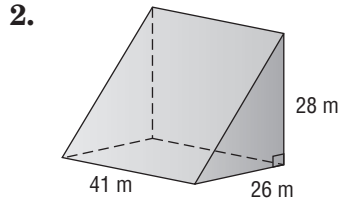
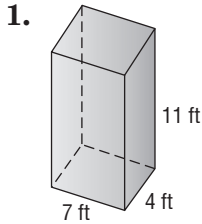

10. rectangular prism: length 18 ft, width 9 ft, height 1 ft
11. triangular prism: base of triangle 22 yd, altitude of triangle 14 yd, height of prism 30 yd
12. Find the height of a cylinder with a radius of 12 inches and a volume of  $3754.8 \text{ in}^3$ . Round to the nearest tenth.

# 11-3 Skills Practice

## Volume: Pyramids, Cones, and Spheres

Find the volume of each solid. If necessary, round to the nearest tenth.

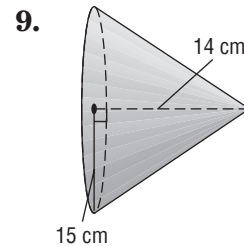
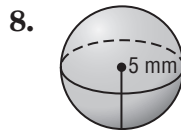
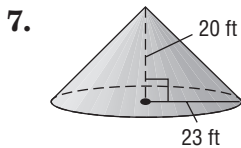
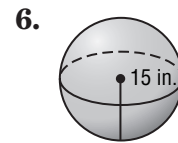
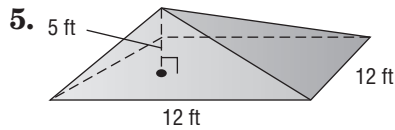
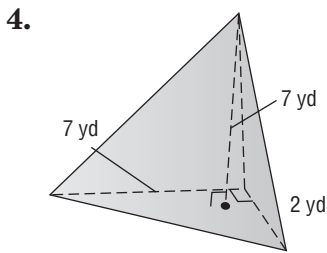
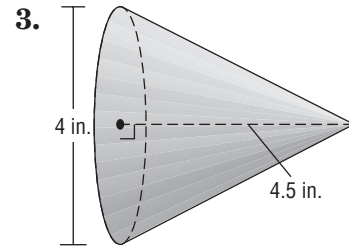
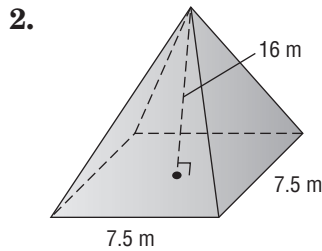
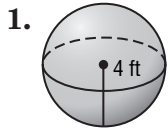

10. rectangular pyramid: length 7 ft, width 2.5 ft, height 8 ft

11. cone: radius 20 cm, height 30 cm

12. sphere: radius 2 in.

# 11-4 Skills Practice

## Surface Area: Prisms and Cylinders

Find the lateral area and surface area of each solid shown or described.  
If necessary, round to the nearest tenth.

1.

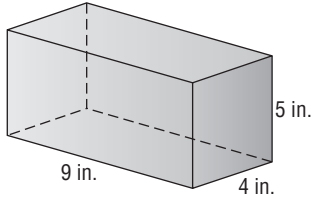

2.

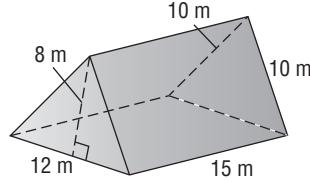

3.

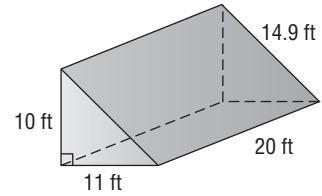

4.

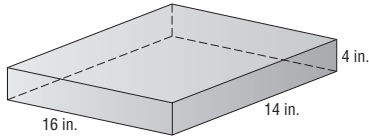

5.

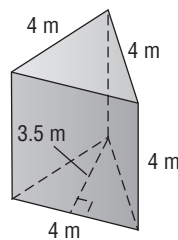

6.

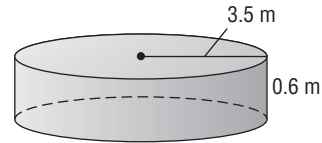

7.

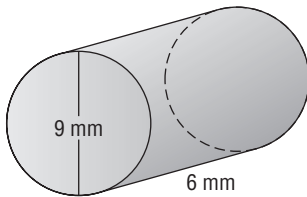

8.

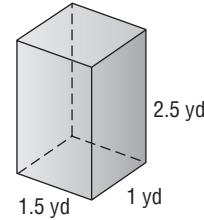

9.



10. rectangular prism: length 17 yd, width 4.5 yd, height 3 yd

11. cylinder: radius 16 ft, height 42 ft

12. cylinder: diameter 20.2 cm, height 43 cm

# 11-5 Skills Practice

## Surface Area: Pyramids and Cones

Find the surface area of each solid. If necessary, round to the nearest tenth.

1.

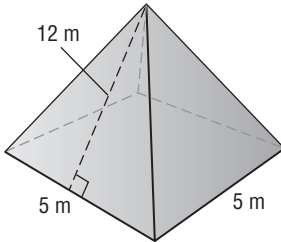

2.

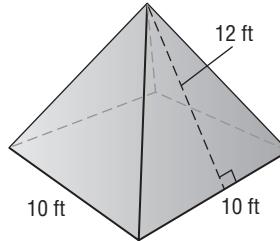

3.

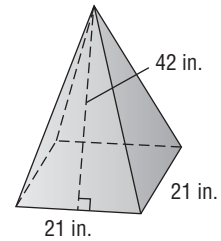

4.

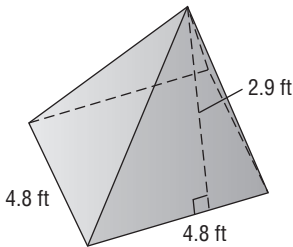

5.

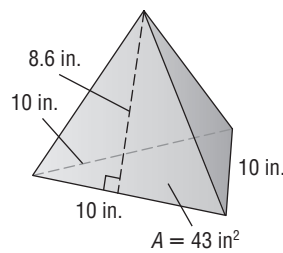

6.

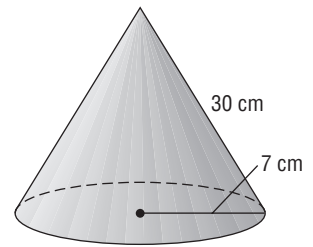

7.

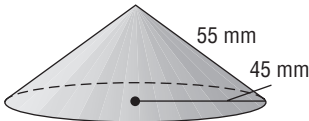

8.

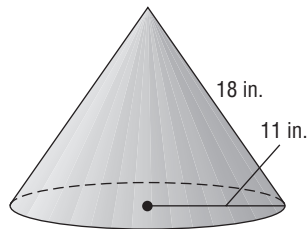

9.

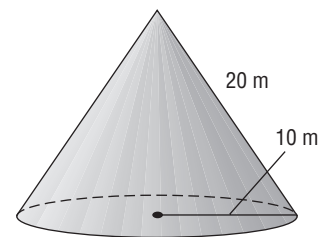

10. square pyramid: base side length 6.3 m, slant height 4 m

11. cone: diameter 16 yd, slant height 10 yd

12. cone: radius 14 cm, slant height 33 cm



# 11-6 Skills Practice

## Similar Solids

Determine whether each pair of solids is similar.

1.

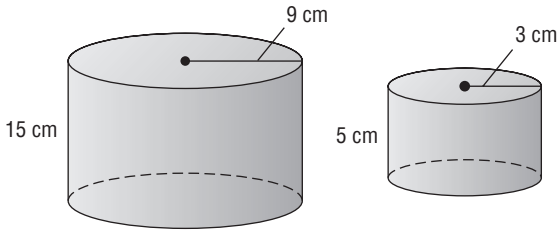

2.

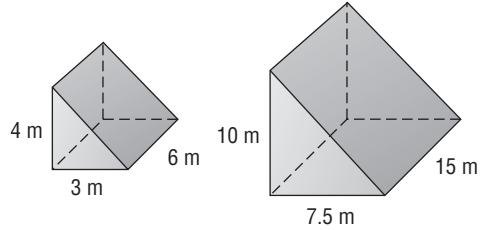

3.

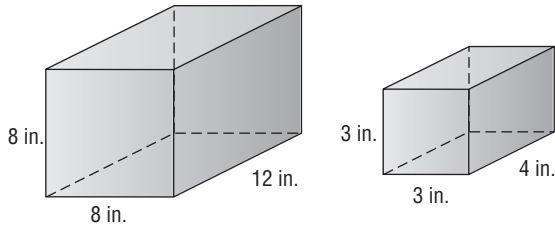

4.

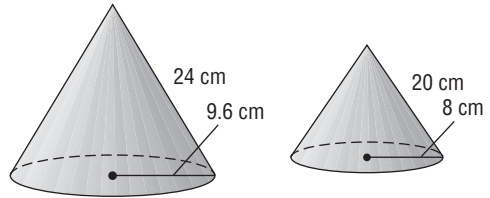

5.

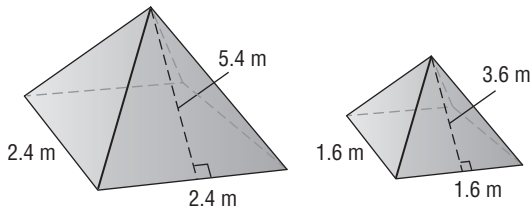

6.

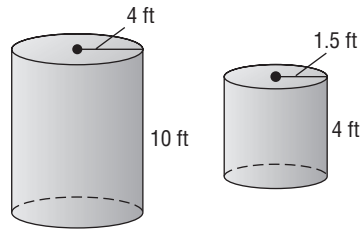

Find the missing measure for each pair of similar solids.

7.

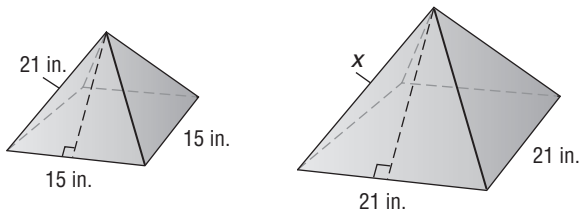

8.

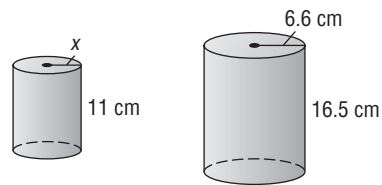

9.

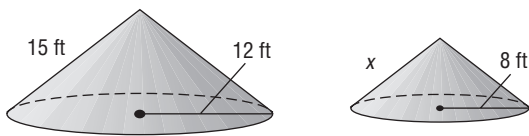

10.

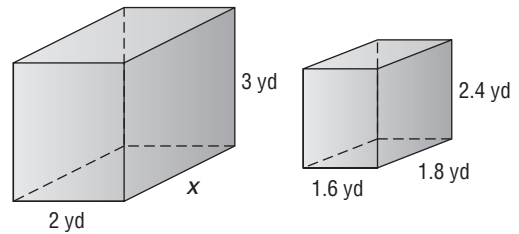

# 12-1 Skills Practice

## Stem-and-Leaf Plots

Display each set of data in a stem-and-leaf plot.

1. {7, 2, 3, 11, 20, 21, 17, 15, 15, 14}

2. {8, 2, 14, 27, 7, 2, 16, 13, 29, 16}

3.

Amount of Fresh Fruit Consumed per Person in the United States, 2002	
Fruit	Pounds Consumed per Person
Apples	16
Bananas	27
Cantaloupes	11
Grapefruit	5
Grapes	9
Oranges	11
Peaches and nectarines	5
Pears	3
Pineapples	4
Plums and prunes	1
Strawberries	5
Watermelons	14

Source: U.S. Census Bureau

4.

Winning Scores in College Football Bowl Games, 2004	
Game and Winning School	Points Scored
Alamo Bowl, Nebraska	17
Fiesta Bowl, Ohio St.	35
Gator Bowl, Maryland	41
Holiday Bowl, Washington St.	28
Liberty Bowl, Utah	17
New Orleans Bowl, Memphis	27
Orange Bowl, Miami	16
Outback Bowl, Iowa	37
Peach Bowl, Clemson	27
Rose Bowl, Oklahoma	34
Sugar Bowl, Louisiana St.	21
Tangerine Bowl, N. Carolina St.	56

Source: footballabout.com

Copyright © Glencoe/McGraw-Hill, a division of The McGraw-Hill Companies, Inc.

Lesson 12-1

**HUMIDITY** For Exercises 5–7, use the information in the back-to-back stem-and-leaf plot. Source: *The New York Public Library Desk Reference*

- What is the highest morning relative humidity?
- What is the lowest afternoon relative humidity?
- Does relative humidity tend to be higher in the morning or afternoon?

U.S. Average Relative Humidity (percent)	
Morning	Afternoon
	5   1 2 3 4 7 9
	6
8 8 4	7
9 4 0	8
8   7 = 78%	5   3 = 53%

# 12-2 Skills Practice

## Measures of Variation

Find the range, interquartile range, and any outliers for each set of data.

1. {7, 9, 21, 8, 13, 19}
2. {33, 34, 27, 40, 38, 35}
3. {37, 29, 42, 33, 31, 36, 40}
4. {87, 72, 104, 94, 85, 71, 80, 98}
5. {92, 89, 124, 114, 98, 118, 115, 106, 101, 149}
6. {6.7, 3.4, 3.8, 4.2, 5.1, 5.8, 6.0, 4.5}
7. {4.3, 1.9, 6.3, 5.1, 2.1, 1.6, 2.4, 5.6, 5.9, 3.5}
8. {127, 58, 49, 101, 104, 98, 189, 111}

9. Stem | Leaf

1	0 0 3 8 9
2	0 5
3	1 2 4

$2 | 0 = 20$

10. Stem | Leaf

7	8 9
8	1 3 7
9	3 5 6

$9 | 3 = 93$

11. Stem | Leaf

0	2 3 6 8 9
1	2 2 5
2	6
3	2 3 4

$1 | 5 = 15$

12. Stem | Leaf

0	1 1 3 3 7 9
1	2 6 7 8 9 9
2	0 1 2 2 4 5 7 9 9 9
3	2 4 6 7 8
4	0 1 3

$2 | 0 = 20$

13. Stem | Leaf

6	0 6
7	1
8	4 9 9
9	1 3 7 7 7 8

$8 | 4 = 84$

14. Stem | Leaf

4	8
5	1 2 4 7 7
6	0 2 5
7	4

$6 | 2 = 62$

**HEALTH** For Exercises 15–17, use the data in the table showing the calories burned by a 125-pound person.

15. What is the range of the data?
16. What is the interquartile range of the data?
17. Are there any outliers?
18. Which activity burns the most calories per hour? The least calories per hour?

Estimated Calories Burned	
Activity	Calories Burned per Hour
Basketball	480
Bicycling	600
Hiking	360
Mowing the Lawn	270
Running	660
Soccer	420
Swimming	600
Weight Training	360
Yoga	240

Source: www.fitresource.com

**12-3 Skills Practice****Box-and-Whisker Plots**

Draw a box-and-whisker plot for each set of data.

1. {6, 9, 22, 17, 14, 11, 18, 28,
- 
- 19, 21, 16, 15, 12, 3}

2. {\$45, \$37, \$50, \$53, \$61, \$95, \$46,
- 
- \$40, \$48, \$62}

3. {14, 9, 1, 16, 20, 17, 18, 11, 15}

4. {\$20, \$35, \$42, \$26, \$53, \$18, \$36, \$27,
- 
- \$21, \$32}

5. {97, 83, 100, 99, 102, 104, 97, 101,
- 
- 115, 106, 94, 108, 102, 100, 109,
- 
- 103, 102, 98, 108}

6. {188, 203, 190, 212, 214, 217, 174, 220,
- 
- 219, 211, 201, 210, 214, 217, 213, 204,
- 
- 187, 206, 210}

7.

Goals Scored by MLS Leading Scorers, 2000		
26	15	12
16	15	1
18	11	10
16	15	5
16	13	9

Source: *World Almanac*

8.

Number of 300 Games per Person in Women's International Bowling Congress		
12	17	23
21	17	23
14	21	12
17	19	24
18	27	13
14	20	12
16	12	16

Source: *World Almanac*

# 12-4 Skills Practice

## Histograms

Display each set of data in a histogram.

1.

Shots per Hockey Game		
Number of Shots	Tally	Frequency
1-7		5
8-14		1
15-21	III	8
22-28		2
29-35		4

2.

Employees in Each Office		
Number of Employees	Tally	Frequency
10-19		2
20-29		6
30-39	III	9
40-49	III	8
50-59		1

3.

Basketball Backboards on Each Playground		
Number of Backboards	Tally	Frequency
0-4		16
5-9		3
10-14	III	8
15-19		11
20-24		0
25-29		4

4.

Population of Loons on Local Lakes		
Number of Loons	Tally	Frequency
30-39		2
40-49		0
50-59		6
60-69	III	9
70-79		17
80-89		4

# 12-5 Skills Practice

## Choosing an Appropriate Display

Choose an appropriate style of display for each data set. Justify your choice.

- the life span of various types of fish
- the number of teachers for 5 different high schools
- the number of students who are in a band, science club, and/or student council
- the names of the Nobel prize winners for the past 50 years
- the total rainfall for several 100-day time intervals
- PARTY** A class of 26 students voted on which type of snack they would like to have at their class party. 13 students voted for brownies, 7 voted for ice cream, 5 voted for cookies, and 2 voted for pretzels. Which graph best represents this situation?

**A. Snack Preference Votes**

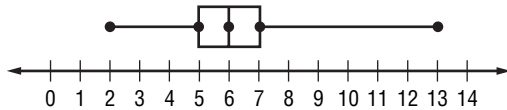

**B.**

Snack	Frequency
Brownies	
Ice Cream	
Cookies	
Pretzels	

**C. Snack Preference**

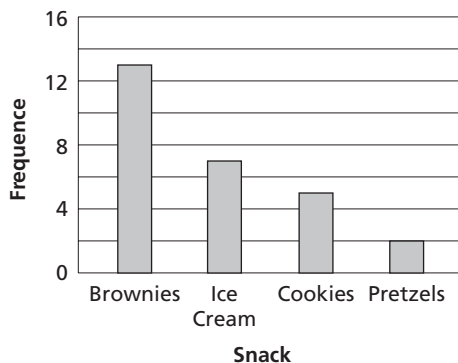

**D. Snack Preference**

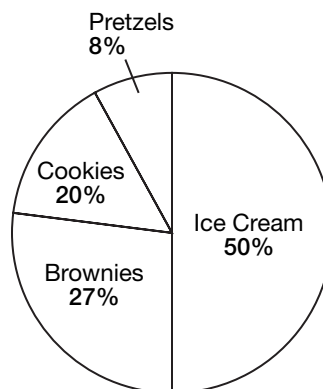

Copyright © Glencoe/McGraw-Hill, a division of The McGraw-Hill Companies, Inc.

# 12-6 Skills Practice

## Misleading Graphs

For Exercises 1–3, refer to the graphs below.

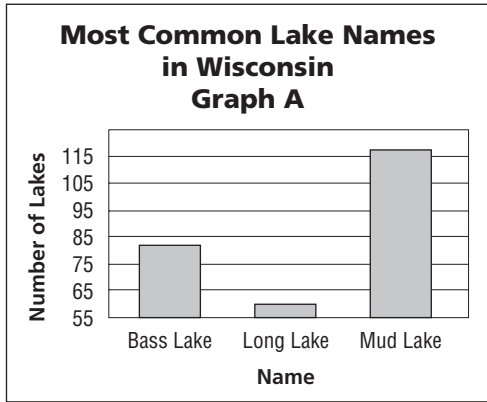

Source: Wisconsin Department of Natural Resources

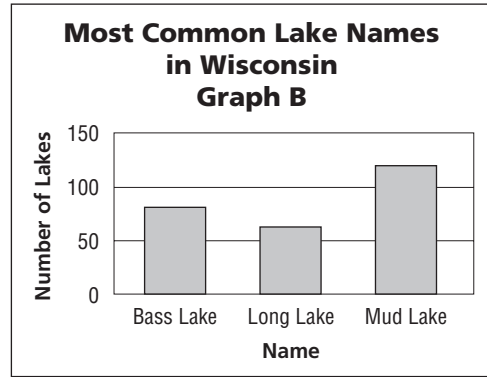

Source: Wisconsin Department of Natural Resources

1. How many lakes in Wisconsin are named Bass Lake? Long Lake? Mud Lake?
2. Which graph gives the impression that only a few lakes are called Long Lake, while numerous lakes are called Bass Lake?
3. What causes the graphs to differ in their appearance?

For Exercises 4–6, refer to the graphs below.

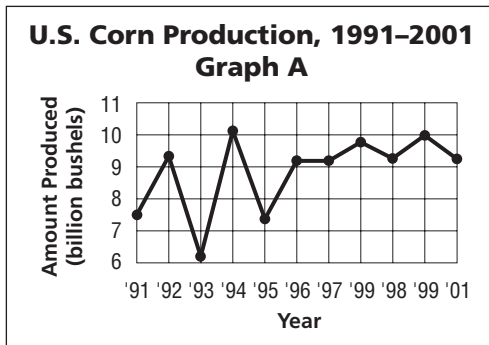

Source: USDA

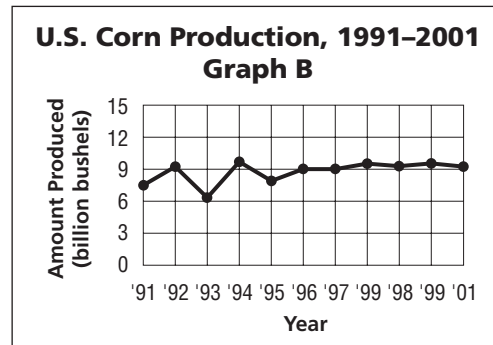

Source: USDA

4. Do these graphs show the same information?
5. Which graph suggests that U.S. corn production is relatively stable?
6. What causes the graphs to differ in their appearance?

# 12-7 Skills Practice

## Simple Probability

A spinner like the one shown is used in a game. Determine the probability of each outcome if the spinner is equally likely to land on each section. Express each probability as a fraction and as a percent.

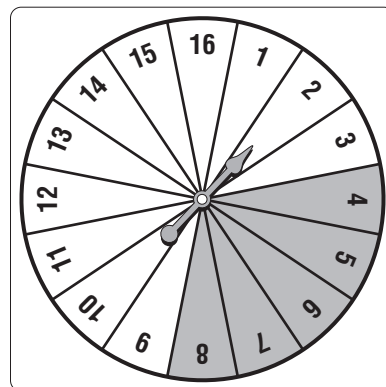

- |                                |                       |                           |
|--------------------------------|-----------------------|---------------------------|
| 1. $P(10)$                     | 2. $P(\text{odd})$    |                           |
| 3. $P(\text{greater than } 7)$ | 4. $P(\text{prime})$  | 5. $P(1 \text{ or } 2)$   |
| 6. $P(\text{less than } 5)$    | 7. $P(\text{Shaded})$ | 8. $P(\text{Not shaded})$ |

There are 4 red marbles, 1 blue marble, 9 green marbles, and 6 yellow marble in a bag. Suppose one marble is selected at random. Find the probability of each outcome. Express each probability as a fraction and as a percent.

- |                             |                       |                                     |
|-----------------------------|-----------------------|-------------------------------------|
| 9. $P(\text{red})$          | 10. $P(\text{blue})$  | 11. $P(\text{yellow})$              |
| 12. $P(\text{red or blue})$ | 13. $P(\text{white})$ | 14. $P(\text{red, blue, or green})$ |

Suppose two 1–6 number cubes are rolled. Find the probability of each outcome. Express each probability as a fraction and as a percent. (*Hint: Make a table to show the sample space as in Example 2.*) Round to the nearest tenth, if necessary.

- |                                   |                               |                                     |
|-----------------------------------|-------------------------------|-------------------------------------|
| 15. $P(3 \text{ or } 5)$          | 16. $P(\text{both even})$     | 17. $P(\text{odd product})$         |
| 18. $P(\text{sum more than } 10)$ | 19. $P(\text{both the same})$ | 20. $P(\text{product is a square})$ |



**12-8 Skills Practice****Counting Outcomes**

**Draw a tree diagram to find the number of outcomes for each situation.**

1. Three coins are tossed.
2. A number cube is rolled and a coin is tossed.

**Find the number of possible outcomes for each situation.**

3. One card is drawn from a standard deck of cards.
4. Three six-sided number cubes are rolled.
5. One coin is flipped three consecutive times.
6. One coin is flipped and one eight-sided die is rolled.
7. A sweater comes in 3 sizes and 6 colors.
8. A restaurant offers dinners with a choice each of two salads, six entrees, and five desserts.

**Find the probability of each event.**

9. Draw the ace of spades from a standard deck of cards.
10. A coin is tossed twice. What is the probability of getting two tails?
11. Draw the six of clubs from a standard deck of cards.
12. Roll a 4 or higher on a six-sided number cube.
13. Roll a 7 or an 8 on an eight-sided die.
14. Roll an even number on an eight-sided die.
15. Draw a club from a standard deck of cards.
16. Roll an odd number on a six-sided number cube.
17. A coin is tossed and an eight-sided die is rolled. What is the probability that the coin lands on tails, and the die lands on a 2?
18. A coin is tossed and a card is drawn from a standard deck of cards. What is the probability of landing on tails and choosing a red card?

**12-9 Skills Practice*****Permutations and Combinations***

**Tell whether each situation is a *permutation* or *combination*. Then solve.**

- How many ways can 6 student desks be arranged in a row?
- How many ways can 18 baseball cards be passed out to 2 students?
- How many ways can 10 students line up for lunch?
- How many ways can you choose 4 CDs from a stack of 8 CDs?
- How many ways can 3 pairs of shoes be chosen from 8 pairs?
- How many ways can 9 runners be arranged on a 4-person relay team?

**Find each value.**

- |          |          |           |
|----------|----------|-----------|
| 7. $9!$  | 8. $5!$  | 9. $3!$   |
| 10. $4!$ | 11. $6!$ | 12. $12!$ |
- SPORTS** The Eastern Division of a baseball league is composed of 5 teams. How many different ways can teams of the Eastern Division finish?
  - LEISURE** The local hobby store has 17 model airplanes to display. If the front case holds 6 models, how many ways can 6 planes be chosen for the front of the store?
  - ZOOS** The local zoo has 23 animals it can take on visits to schools and other community centers. How many ways can the zoo directors choose 9 animals for a trip to a middle school?
  - CULTURE** There are 15 Irish dancers in a championship-level competition. How many ways can the top 3 finishers be arranged?
  - RACING** In an auto race, the cars start in 11 rows of 3. How many ways can the front row be made from the field of 33 race cars?

**TELEVISION** For Exercises 18 and 19, use the following information.  
**A television network has a choice of 11 new shows for 4 consecutive time slots.**

- How many ways can four shows be chosen, without considering the age of the viewers or the popularity of the time slots?
- How many ways can the shows be arranged if the time slots are during prime time and in competition for viewers?

# 12-10 Skills Practice

## Probability of Composite Events

A number cube is rolled and the spinner is spun.  
Find each probability.

1.  $P(2 \text{ and green triangle})$
2.  $P(\text{an odd number and a circle})$
3.  $P(\text{a prime number and a quadrilateral})$
4.  $P(\text{a number greater than 4 and a parallelogram})$

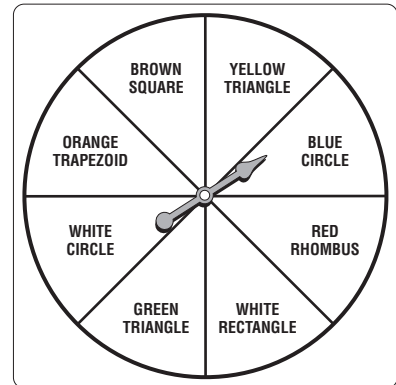

There are 5 yellow marbles, 1 purple marble, 3 green marbles, and 3 red marbles in a bag. Once a marble is drawn, it is replaced. Find the probability of each outcome.

- |                                 |                                |
|---------------------------------|--------------------------------|
| 5. a purple then a red marble   | 6. a red then a green marble   |
| 7. two green marbles in a row   | 8. two red marbles in a row    |
| 9. a purple then a green marble | 10. a red then a yellow marble |

There are 4 yellow marbles, 3 purple marbles, 1 green marble, and 1 white marble in a bag. Once a marble is drawn, it is *not* replaced. Find the probability of each outcome.

- |                                   |                                 |
|-----------------------------------|---------------------------------|
| 11. a purple then a white marble  | 12. a white then a green marble |
| 13. two purple marbles in a row   | 14. two yellow marbles in a row |
| 15. a yellow then a purple marble | 16. a green then a white marble |

A card is drawn from a standard deck of cards. Find the probability of each outcome.

- |  |  |
|--|--|
| 17. $P(\text{a red card or a club})$           | 18. $P(\text{a diamond or a spade})$           |
| 19. $P(\text{a face card or a 2})$             | 20. $P(\text{a 7 or a 9})$                     |
| 21. $P(\text{a red card or a king of spades})$ | 22. $P(\text{a heart or a queen of diamonds})$ |

**13-1 Skills Practice****Polynomials**

Determine whether each expression is a polynomial. If it is, classify it as a *monomial*, *binomial*, or *trinomial*.

1.  $-5g^8$

2.  $x + 2y + z$

3.  $5x + 1 + \frac{4}{x}$

4.  $r^2 - 9r$

5.  $d + 1$

6.  $a^3b^2 + a^2$

7.  $n$

8.  $17 - \sqrt{c}$

9.  $a + b^2 - 3$

10.  $m + 2\sqrt{m}$

11.  $5y^2 - 3y + 1$

12.  $a - b + c$

13.  $24x^3$

14.  $25 - 9h^4$

15.  $u^5 + u^3 + u$

16.  $\frac{3x^3}{4} + \frac{x}{2} + \frac{1}{8}$

17.  $\frac{x}{5} + \frac{1}{2}$

18.  $\frac{6}{a^2} - \frac{1}{a} + \frac{1}{3}$

19.  $1$

20.  $9y - \sqrt{5}$

21.  $27g^5h^2$

Find the degree of each polynomial.

22.  $14$

23.  $ab$

24.  $b$

25.  $c^3 + c^2 + c + 1$

26.  $mn^5$

27.  $xy^3z + 1$

28.  $k - 4$

29.  $\frac{-5}{6}$

30.  $9.7$

31.  $c^6de^3 + c^5 + d$

32.  $a^2 - 2a + 3$

33.  $k^3 + 3k^4$

34.  $xy^2 + 4x^2y + y^2$

35.  $7b^5 - 10$

36.  $16g + 3$

37.  $8y^2 + 8y - 5$

38.  $abc + 2ab + 5c - bc + 1$

39.  $-4g^2h^5 + 2gh^4 + 9$

**13-2 Skills Practice*****Adding Polynomials*****Find each sum.**

$$\begin{array}{r} 1. \quad 5q + 7 \\ (+) 2q - 2 \\ \hline \end{array}$$

$$\begin{array}{r} 2. \quad 7f - 10 \\ (+) -2f + 3 \\ \hline \end{array}$$

$$\begin{array}{r} 3. \quad r^2 - 3r \\ (+) r^2 + 4r - 1 \\ \hline \end{array}$$

$$\begin{array}{r} 4. \quad 9n^2 - 3n \\ (+) \quad 3n - 5 \\ \hline \end{array}$$

$$\begin{array}{r} 5. \quad w^2 - 3w + 3 \\ (+) w^2 + 4w + 1 \\ \hline \end{array}$$

$$\begin{array}{r} 6. \quad 8c^2 - 4c + 6 \\ (+) c^2 + c - 1 \\ \hline \end{array}$$

$$\begin{array}{r} 7. \quad -p^2 + 6p + 8 \\ (+) p^2 - 4p - 5 \\ \hline \end{array}$$

$$\begin{array}{r} 8. \quad 3v^2 + v \\ (+) -2v + 7 \\ \hline \end{array}$$

$$\begin{array}{r} 9. \quad 6m^2 + m + 1 \\ (+) 2m^2 - 2m - 3 \\ \hline \end{array}$$

$$\begin{array}{r} 10. \quad 5d^2 + 7d - 4 \\ (+) 5d^2 - 6d - 4 \\ \hline \end{array}$$

$$11. (2r^2 - 3) + (-r^2 + 4r + 1)$$

$$12. (g^2 + 2g + 5) + (5g^2 - 2g + 3)$$

$$13. (-m - 9) + (3m - 3)$$

$$14. (2x^2 + 8x - 7) + (3x + 5)$$

$$15. (k^2 - k) + (7k^2 - k - 2)$$

$$16. (4a^2 + 3ab) + (ab + 2b^2)$$

$$17. (5c - 7) + (3c^2 - 4c + 6)$$

$$18. (x^2 + xy) + (xy + y^2)$$

$$19. (-h^2 + 3h - 6) + (4h^2 - 2h + 3)$$

$$20. (x^2 + x + 1) + (2x - 9x^2)$$

$$21. (6g^2 - 2g - 3) + (2g^2 + 5g)$$

$$22. (b^2 + b + 1) + (b^2 - b - 1)$$

$$23. (2y^2 - 7y + 9) + (y^2 - 4y - 6)$$

$$24. (7p^3 - 4) + (2p^2 + 5p + 1)$$

# 13-3 Skills Practice

## Subtracting Polynomials

Find each difference.

$$\begin{array}{r} 1. \quad 7y + 5 \\ (-) y + 6 \\ \hline \end{array}$$

$$\begin{array}{r} 2. \quad k + 8 \\ (-) 2k - 9 \\ \hline \end{array}$$

$$\begin{array}{r} 3. \quad w^2 + w + 1 \\ (-) 2w^2 + 3w + 2 \\ \hline \end{array}$$

$$\begin{array}{r} 4. \quad c^2 - 7c + 2 \\ (-) -c^2 - c - 1 \\ \hline \end{array}$$

$$\begin{array}{r} 5. \quad 3d^2 - d \\ (-) d^2 - 3d - 8 \\ \hline \end{array}$$

$$\begin{array}{r} 6. \quad 7n^2 - 3n \\ (-) -n^2 - 3n - 1 \\ \hline \end{array}$$

$$\begin{array}{r} 7. \quad 2m^2 - 5m + 3 \\ (-) 5m^2 - m - 3 \\ \hline \end{array}$$

$$\begin{array}{r} 8. \quad d^2 - 3d - 6 \\ (-) d^2 - 2d - 1 \\ \hline \end{array}$$

$$\begin{array}{r} 9. \quad -q^2 + 2q + 2 \\ (-) q^2 - 7q + 9 \\ \hline \end{array}$$

$$\begin{array}{r} 10. \quad v^2 + v \\ (-) 8v^2 - 8v + 8 \\ \hline \end{array}$$

$$11. (r^2 - 10r - 3) - (-r^2 - r + 1)$$

$$12. (7k^2 + k + 8) - (2k^2 - 3k - 3)$$

$$13. (a^2 - 9) - (a - 4)$$

$$14. (4x^2 + 11x - 7) - (x^2 - 3x - 6)$$

$$15. (k^2 - 3k) - (2k^2 - 7k - 1)$$

$$16. (5a^2 + ab) - (ab + 3b^2)$$

$$17. (5u^2 - 7) - (3u^2 - 4u + 6)$$

$$18. (4m^2 + mn) - (3mn + n^2)$$

$$19. (h^2 + 3h - 6) - (h^2 - 2h - 3)$$

$$20. (x^2 - x - 1) - (2x + 9x^2)$$

$$21. (6g^2 + 3g + 3) - (g^2 + g - 5)$$

$$22. (b^2 + b + 1) - (b^2 - b - 1)$$

$$23. (a^2 - 9a - 10) - (a^2 - a - 4)$$

$$24. (4r^2 + 7r) - (3r^2 - 2r + 7)$$

**13-4 Skills Practice*****Multiplying a Polynomial by a Monomial*****Find each product.**

1.  $4(k + 7)$

2.  $(5h + 3)3$

3.  $-9(2q + 7)$

4.  $(6v - 1)(-6)$

5.  $-8(5h - 6)$

6.  $3(12y - 6)$

7.  $(9d + 3)4$

8.  $-5(5n - 9)$

9.  $2(x^2 + 4)$

10.  $-6(5x^2 - 3x)$

11.  $(4x^2 - 6x - 9)9$

12.  $-7(2c^2 - 8c + 5)$

13.  $g(2g + 5)$

14.  $-b(9b - 6)$

15.  $(4y + 7)y$

16.  $(2j - 1)(-j)$

17.  $-c(c - 2)$

18.  $h(6h + 4)$

19.  $(6k + 6)(-k)$

20.  $p(3p - 8)$

21.  $-a(8a + 2)$

22.  $r(r^2 + 7r)$

23.  $x(4x^2 - 2x - 1)$

24.  $ab(3ab + 2a)$

25.  $x(4xy - 3y^2)$

26.  $(gh - h)(-g)$

27.  $x(4x^2 - xy + y^2)$

28.  $6v(3v + 9)$

29.  $(u + 4)(-5u)$

30.  $8b(b - 6)$

31.  $-7d(5d - 9)$

32.  $(8w - 4)w$

33.  $a(7a + 4)$

34.  $(6y - 6)(-y^2)$

35.  $s(s + 1)$

36.  $-m(6m - 7)$

37.  $-k^2(2k - 3)$

38.  $c(7c^2 + 3c - 4)$

39.  $7mn(m + 2mn + 4n)$

40.  $8a(a + ab + b)$

41.  $(xy - y^2)(-4xy)$

42.  $-8u(7u^2 - 2uv + 4v^2)$

# 13-5 Skills Practice

## Linear and Nonlinear Functions

Determine whether each graph, equation, or table represents a *linear* or *nonlinear* function. Explain.

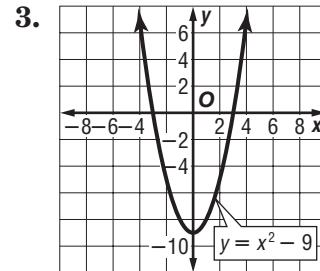
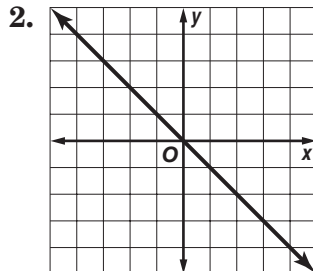
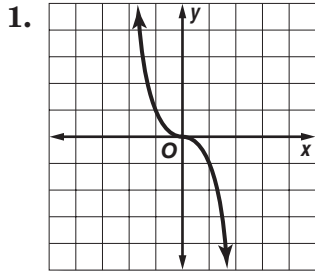

4.  $y = \frac{x}{2} + 1$

5.  $y = \frac{2}{x} + 10$

6.  $y = 8x$

7.  $y = 6$

8.  $2x - y = 5$

9.  $y = x^2 + 4$

10.  $y + 4x^2 - 1 = 0$

11.  $2y - 8x + 11 = 0$

12.  $y = \sqrt{3x} - 2$

13.

x	y
1	8
2	5
3	2
4	-1

14.

x	y
6	1
12	3
18	6
24	10

15.

x	y
20	-4
15	-2
10	0
5	2



# 13-6 Skills Practice

## Graphing Quadratic and Cubic Functions

Graph each function.

1.  $y = 5x^2$

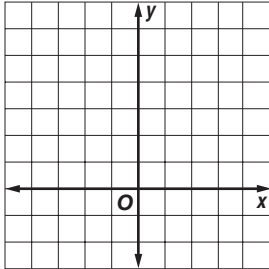

2.  $y = 5x^3$

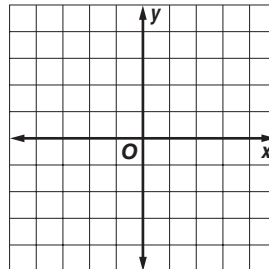

3.  $y = -5x^2$

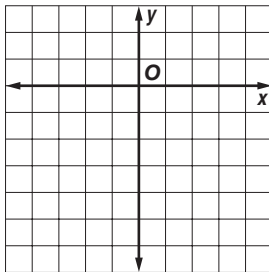

4.  $y = -5x^3$

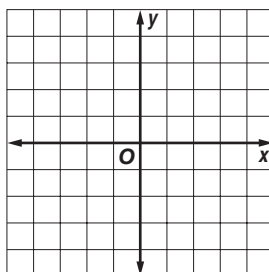

5.  $y = x^2 + 4$

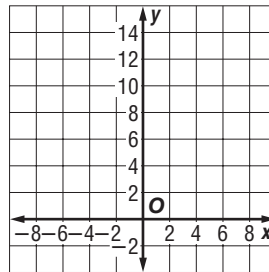

6.  $y = x^3 + 4$

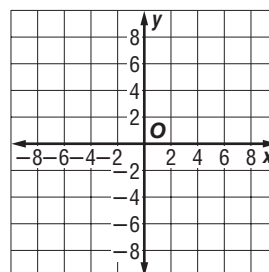

7.  $y = x^2 - 4$

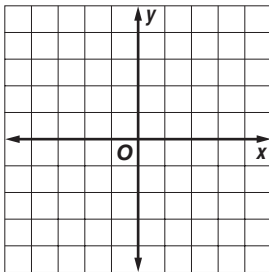

8.  $y = x^3 - 4$

