

**1-1 Practice****Using a Problem-Solving Plan****Solve each problem.**

- 1. RETAIL** At a school bookstore, a ballpoint pen costs \$0.28 and a notepad costs \$0.23. What could you buy and spend for exactly 0.74?
- 2. SOCCER** At soccer practice, each player must kick the ball to every other player present at least once. If there are 17 players at practice, what is the minimum number of kicks required?
- 3. MONEY** Mr. Jasper asked his neighbor, Mark, to feed his cat each day while he went on a two-week vacation. Suppose Mr. Jasper offered Mark two payment options. The first option would pay Mark \$5 per day up front. The second option would pay \$0.01 the first day, then double the pay each day for two weeks. He would pay this option when he returned. Which option should Mark choose?
- 4. NUMBER THEORY** Use the following clues to find the secret number.

I am a 3-digit number.

All of my digits are odd.

I am less than 600.

I am greater than 400.

If you add my digits you get 15.

My last digit is 7.

What am I?

**Find the next term in each list.**

5. 9, 13, 17, 21, 25, ...

6. 88, 86, 84, 82, 80, ...

7. 0, 7, 14, 21, 28, ...

8. 3, 6, 12, 24, 48, ...

**GEOMETRY** Draw the next figure in each pattern.9.  .10.  .

**1-2 Practice*****Numbers and Expressions***

Find the value of each expression.

1.  $4 + 2 \cdot 8$
2.  $30 - 12 \cdot 2$
3.  $6(6 \div 2) \cdot 9$
4.  $6(6) \div 2 \cdot 9$
5.  $6(6) \div (2 \cdot 9)$
6.  $6(6 \div 2 \cdot 9)$
7.  $12 - 2 \cdot 5 + 3$
8.  $(4 + 5) \cdot (4 + 5)$
9.  $100 \div (16 + 9) \cdot 6$
10.  $25 + 30 \div 6 \cdot 5$
11.  $16 - 49 \div 7 \cdot 2$
12.  $(2 \cdot 11 + 1) - (3 \cdot 6 + 5)$
13.  $\frac{4(10 + 2)}{2(24 \div 3)}$
14.  $2 + 4 \cdot 6 - 3 \cdot 5 + 6 \cdot 2$
15.  $(8 + 4) \cdot (6 - 3)$
16.  $\frac{2(6 + 4)}{2(8 - 6)}$
17.  $4(8 + 2 \cdot 5 - 6)$
18.  $2(105 \div 15 - 6)$
19.  $14 \div 2 \cdot 5 + 3$
20.  $4(4 + 5) \div 3(10 - 7)$

Write a numerical expression for each verbal phrase.

21. thirty-one increased by fourteen
22. the difference of sixteen and nine
23. the sum of seven, four, and eighteen
24. three times forty
25. the quotient of eighty-one and three
26. four more than the product of seven and eight
27. the cost of three slices of pizza at \$2 each
28. the number of days in six weeks
29. **BOWLING** Alicia rented bowling shoes for \$3 and played 4 games at \$2 each. Write and evaluate an expression for the total cost of bowling.
30. **TICKETS** Adult tickets for a movie cost \$6 and children's tickets cost \$3. If two adults and three children go to the movies, how much will they pay?

**1-3 Practice*****Variables and Expressions*****ALGEBRA** Evaluate each expression if  $x = 12$ ,  $y = 20$ , and  $z = 4$ .

- |                        |                                |
|------------------------|--------------------------------|
| 1. $x + y + z$         | 2. $4x - y$                    |
| 3. $3x + 2y$           | 4. $y - 3z$                    |
| 5. $x + y \div z$      | 6. $yz + x$                    |
| 7. $(y - x) + (y - z)$ | 8. $\frac{y}{z} + \frac{x}{z}$ |
| 9. $\frac{5x}{3y}$     | 10. $z(y - x) + 4z$            |

**ALGEBRA** Evaluate each expression if  $a = 3$ ,  $b = 6$ ,  $c = 5$ , and  $d = 9$ .

- |                                 |                             |
|---------------------------------|-----------------------------|
| 11. $a + b + c + d$             | 12. $\frac{(a + b + c)}{2}$ |
| 13. $ab + bc$                   | 14. $6d - c \cdot c$        |
| 15. $3(a + b + c)$              | 16. $\frac{100}{5c}$        |
| 17. $abc$                       | 18. $10(6c - 3d)$           |
| 19. $\frac{2(a + b)}{6(b - c)}$ | 20. $4[(d - a) + c]$        |

**ALGEBRA** Translate each phrase into an algebraic expression.

21. six times a number minus eleven
22. the product of eight hundred and a number
23. the quotient of thirty and the product of ten times a number
24. five times the sum of three and some number
25. half the distance to the school.
26. **RECYCLING** In order to encourage recycling, the city is offering five cents for every pound of newspapers collected, twenty-five cents per pound for cans, and ten cents per pound for glass bottles or jars.
  - a. Write an expression for the total amount earned from recycling.
  - b. If Chen brings in ten pounds of newspapers, eight pounds of cans, and two pounds of glass, how much will he receive?

**1-4 Practice****Properties**

Name the property shown by each statement.

- $55 + 6 = 6 + 55$
- $6 \cdot 7 = 7 \cdot 6$
- $(x + 3) + y = x + (3 + y)$
- $1 \cdot mp = mp$
- $9 + (5 + 35) = (9 + 5) + 35$
- $67 + 0 = 67$
- $7x \cdot 0 = 0$
- $4(3 \cdot z) = (4 \cdot 3)z$

Find each sum or product mentally.

- |                           |                           |
|---------------------------|---------------------------|
| 9. $18 + 17 + 22$         | 10. $12 + 15 + 8 + 5$     |
| 11. $60 \cdot 4 \cdot 2$  | 12. $49 \cdot 0 \cdot 16$ |
| 13. $2 \cdot 157 \cdot 5$ | 14. $14 + 25 + 16$        |

**ALGEBRA** Simplify each expression.

- |                     |                            |
|---------------------|----------------------------|
| 15. $(m + 11) + 19$ | 16. $(9 \cdot b) \cdot 10$ |
| 17. $19 + (v + 8)$  | 18. $(28 + 12) + x$        |
| 19. $8s \cdot 0$    | 20. $4 \cdot (r \cdot 5)$  |

- GEOMETRY** The volume of a box is given by  $V = \ell \cdot w \cdot h$  where  $\ell$  = length,  $w$  = width, and  $h$  = height. Find the volume of a box if length is 25 cm, width is 13 cm, and height is 4 cm.
- SCHOOL** In math class each assignment is worth 20 points. David got 17, 20, 19, and 13 points on his last four assignments. How many points did David score altogether?
- State whether the following statement is true or false: Multiplying any number by one produces the original number. Explain.

**1-5 Practice*****Variables and Equations*****ALGEBRA** Find the solution of each equation from the list given.

1.  $w + 16 = 31$ ; 13, 15, 17
2.  $z + 31 = 72$ ; 37, 39, 41
3.  $25 - p = 0$ ; 21, 23, 25
4.  $s - 14 = 2$ ; 12, 14, 16
5.  $19 = t - 21$ ; 40, 42, 44
6.  $b = 15 - 3$ ; 12, 14, 16
7.  $9q = 72$ ; 6, 8, 10
8.  $35 = 5m$ ; 7, 9, 11
9.  $\frac{75}{n} = 15$ ; 5, 7, 9
10.  $\frac{p}{8} = 10$ ; 80, 84, 88

**ALGEBRA** Solve each equation mentally.

11.  $g + 19 = 29$
12.  $26 + h = 35$
13.  $n - 6 = 12$
14.  $36 \div a = 12$
15.  $\frac{90}{45} = u$
16.  $3t = 39$
17.  $15 + r = 30$
18.  $34 - v = 20$

**ALGEBRA** Define a variable. Then write an equation and solve.

19. The sum of 3, 5, and a number is 15.
20. The difference of a number and 16 is 5.
21. The quotient of 56 and a number is 7.
22. A number increased by 30 is 63.
23. Eight times a number is 32.
24. A number decreased by 4 is 41.
25. **WEATHER** During the month of July, meteorologists recorded 5 inches of rainfall. This is 6 inches below average. Define a variable and write an equation that can be used to determine the average rainfall for July. Find the average rainfall for July.
26. **FOOD** Junot and Lisa ordered a pizza and cut it into six slices. If Junot ate one slice and Lisa ate one slice, how many slices are left?

# 1-6

## Practice

### Ordered Pairs and Relations

Graph each point on the coordinate system.

- 1.  $Q(4, 2)$
- 2.  $V(3, 7)$
- 3.  $T(0, 3)$
- 4.  $B(8, 6)$
- 5.  $R(5, 0)$
- 6.  $L(4, 4)$

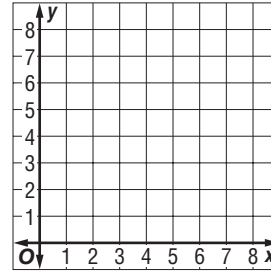

Write the ordered pair that names each point.

- 7.  $J$
- 8.  $X$
- 9.  $R$
- 10.  $B$
- 11.  $K$
- 12.  $H$
- 13.  $D$
- 14.  $N$

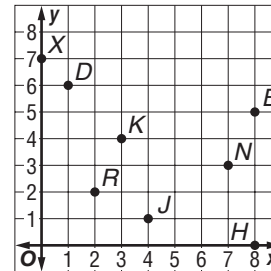

Express each relation as a table and as a graph. Then determine the domain and range.

15.  $\{(3, 7), (1, 1), (6, 5), (2, 4)\}$

16.  $\{(0, 2), (4, 6), (3, 7)\}$

x	y

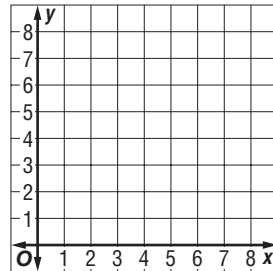

x	y

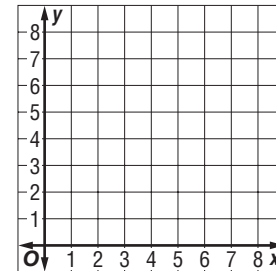

17. **GEOMETRY** Graph  $(2, 1)$ ,  $(2, 4)$ , and  $(5, 1)$  on the coordinate system.

- a. Connect the points with line segments. What figure is formed?
- b. Multiply each number in the set of ordered pairs by 2. Graph and connect the new ordered pairs. What figure is formed?
- c. Compare the two figures you drew. Write a sentence that tells how the figures are the same and how they are different.

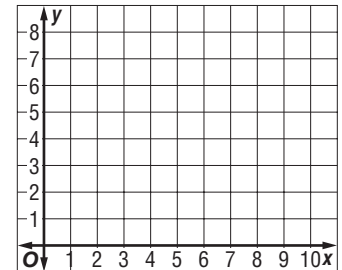

**1-7**

**Practice**  
**Scatter Plots**

Determine whether a scatter plot of the data for the following might show a *positive*, *negative*, or *no* relationship.

1. a person's jogging speed and time spent jogging
2. the size of a family and the weekly grocery bill
3. the size of a car and the cost
4. a person's weight and percent body fat
5. time spent playing video games and time spent on outdoor activity
6. Draw a scatter plot with ten ordered pairs that shows a negative relationship.

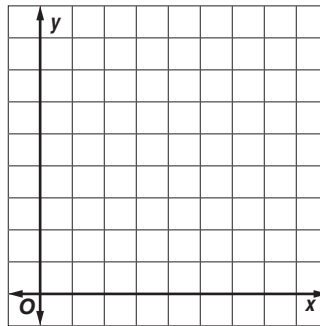

**EMPLOYMENT** For Exercises 7–9, use the table below, which shows the federal minimum wage rates from 1950 to 2000.

Year	Minimum Wage
1950	\$0.75
1955	\$0.75
1960	\$1.00
1965	\$1.25
1970	\$1.60
1975	\$2.10
1980	\$3.10
1985	\$3.35
1990	\$3.80
1995	\$4.25
2000	\$5.15

Source: U.S. Census Bureau

7. Make a scatter plot of the data.



8. Does there appear to be a relationship between year and minimum wage?
9. Based on the graph, predict what the minimum wage will be for the year 2010.

**2-1 Practice*****Integers and Absolute Value***

Replace each  $\bullet$  with  $<$ ,  $>$ , or  $=$  to make a true sentence.

1.  $0 \bullet -5$

2.  $10 \bullet -10$

3.  $-8 \bullet 3$

4.  $11 \bullet 11$

5.  $-18 \bullet -18$

6.  $-18 \bullet 18$

7.  $18 \bullet -18$

8.  $18 \bullet 18$

9.  $-120 \bullet -95$

10.  $35 \bullet -12$

11.  $-35 \bullet 12$

12.  $41 \bullet 17$

Order the integers in each set from least to greatest.

13.  $\{-14, -6, -22, 0\}$

14.  $\{-3, 19, 0, -5\}$

15.  $\{-7, 20, -21, 7\}$

16.  $\{15, -1, 4, -3\}$

17.  $\{0, -1, 2, -3, 4\}$

18.  $\{55, 0, -60, 12\}$

19.  $\{-48, -30, -49, -8, 3, -4\}$

20.  $\{27, -9, 3, 0, -2, 29\}$

Evaluate each expression.

21.  $|-7|$

22.  $|14|$

23.  $|-11|$

24.  $|-9| - |6|$

25.  $|-18| - |-8|$

26.  $|-12| + |1|$

27.  $|8 - 4|$

28.  $|23| - |18|$

29.  $|-16| + |-22|$

Evaluate each expression if  $a = -3$ ,  $b = 0$ , and  $c = 1$ .

30.  $|a| - |c|$

31.  $|a| + |c|$

32.  $|ab| + c$

33.  $5 - |ac|$

34.  $c + |-5|$

35.  $c + |5|$

**36. WEATHER** At 6:15 a.m. the temperature was  $-8^{\circ}\text{F}$ . At 12:15 p.m. the temperature was  $-12^{\circ}\text{F}$ . At 6:16 p.m. the temperature was  $-10^{\circ}\text{F}$ . Order the temperatures from least to greatest.



**2-2 Practice*****Adding Integers*****Find each sum.**

1.  $-19 + (-7)$

2.  $-29 + 30$

3.  $-32 + 9$

4.  $10 + 37$

5.  $34 + 22$

6.  $-16 + (-28)$

7.  $-4 + (-50)$

8.  $-12 + (-63)$

9.  $26 + (-9)$

10.  $-17 + (-23)$

11.  $12 + (-22)$

12.  $18 + (-56)$

13.  $-36 + (-36)$

14.  $-54 + 45$

15.  $-34 + 17$

16.  $-16 + (-24)$

17.  $70 + (-108)$

18.  $-52 + 36$

19.  $-71 + (-86)$

20.  $-39 + (-40)$

21.  $25 + 18 + (-23)$

22.  $-65 + (-2) + 9$

23.  $80 + 15 + (-26)$

24.  $-5 + 4 + (-27)$

25.  $-29 + 12 + 44$

26.  $-1 + (-8) + (-49)$

27.  $-16 + (-56) + (-90)$

28.  $-18 + 13 + (-35)$

29.  $10 + (-34) + 17$

30.  $30 + (-9) + 1$

31.  $-24 + 7 + 47$

32.  $51 + (-21) + (-12)$

**33. TEMPERATURE** At 4:00 A.M., the outside temperature was  $-28^{\circ}\text{F}$ . By 4:00 P.M. it rose 38 degrees. What was the temperature at 4:00 P.M.?

**34. HEALTH** Three friends decided to exercise together four times a week to lose fat and increase muscle mass. While all three were healthier after six weeks, one had lost 5 pounds, another had gained 3 pounds, and one had lost 4 pounds. What was the total number of pounds gained or lost by the three friends?

**35. ROLLER COASTERS** The latest thrill ride at a popular theme park takes roller coaster fans on an exciting ride. In the first 20 seconds, it carries its passengers up a 100-meter hill, plunges them 72 meters down, and quickly takes them back up a 48-meter rise. How much higher or lower from the start of the ride are they after these 20 seconds?

**2-3 Practice*****Subtracting Integers***

Find each difference.

1.  $-26 - (-30)$

2.  $25 - 32$

3.  $-18 - 54$

4.  $59 - (-19)$

5.  $-41 - (-19)$

6.  $-20 - 13$

7.  $31 - (-56)$

8.  $15 - (-40)$

9.  $-32 - 28$

10.  $10 - (-23)$

11.  $-14 - 64$

12.  $-12 - (-36)$

13.  $-81 - 4$

14.  $9 - 30$

15.  $-44 - (-21)$

16.  $140 - (-9)$

Evaluate each expression if  $a = -11$ ,  $b = 8$ , and  $c = -6$ .

17.  $a - 17$

18.  $10 - b$

19.  $-30 - c$

20.  $b - a$

21.  $a - b$

22.  $c - b$

23.  $b - c + a$

24.  $b - c - a$

25.  $c - a - b$

26.  $b + a - c$

27.  $b + c - a$

28.  $c - a + b$

29.  $a - b + c$

30.  $b - a + c$

31.  $a - b - c$

32.  $c + b - a$

33.  $c - b + a$

34.  $a + b - c$

35.  $16 + a + c$

36.  $a - b + 14$

**37. ELEVATORS** Linda entered an elevator on floor 9. She rode down 8 floors. Then she rode up 11 floors and got off. What floor was she on when she left the elevator?

**38. INVESTMENTS** The NASDAQ lost 36 points on a Monday, but rebounded the next day, gaining 24 points. What was the total change in points?

**39. OFFICE BUILDINGS** Randi takes the stairs at work whenever possible instead of the elevator. She must climb up 51 steps from her office to get to the accounting department. The human resources department is 34 steps below her office. How many steps are there between human resources and accounting?

**2-4 Practice*****Multiplying Integers*****Find each product.**

1.  $8(16)$

2.  $-4(17)$

3.  $-1(-40)$

4.  $-5(-7)$

5.  $0(-54)$

6.  $29(-2)$

7.  $-20(-20)$

8.  $-31(-4)$

9.  $-2(-15)(-6)$

10.  $3(-5)(-8)$

11.  $-10(17)(-2)$

12.  $-2(-2)(-2)$

13.  $12(10)(5)$

14.  $-50(-21)(2)$

15.  $-8(-13)(-25)$

16.  $-5(16)(4)$

**ALGEBRA Simplify each expression.**

17.  $-6r \cdot (12s)$

18.  $-15 \cdot (9v)$

19.  $2ab \cdot (-25)$

20.  $-27y \cdot (-z)$

21.  $-60m(-2)(-3n)$

22.  $-9u(-4)(-w)$

23.  $29g(0)(-15)$

24.  $-b(-12)(11)$

25.  $19h(-1)(-2s)$

26.  $-h(-jk)$

27.  $(-1)(-a)(-bc)$

28.  $(-1)(-fg)(-xy)$

**ALGEBRA Evaluate each expression if  $a = -1$ ,  $b = -6$ , and  $c = 5$ .**

29.  $-11a$

30.  $4ab$

31.  $-8bc$

32.  $-10ac$

33.  $15ab$

34.  $12ac$

35.  $abc$

36.  $-abc$

37.  $-11a(-bc)$

38.  $4ab(-8c)$

39.  $9a(-2b)(5c)$

40.  $-3a(-2b)(-c)$

**41. REAL ESTATE** In Montyville, the value of homes has experienced an annual increase of  $-2$  percent. If the rate continues, what will be the increase over 10 years?

**42. RETAIL** The Good Food n' More grocery store loses an average of \$210 a day due to breakage, shoplifting, and food expiration. How much money does the store lose on average per 7-day week?

**2-5 Practice*****Dividing Integers*****Find each quotient.**

1.  $-44 \div 4$

2.  $0 \div (-5)$

3.  $-21 \div 21$

4.  $32 \div 8$

5.  $-17 \div -17$

6.  $-49 \div 7$

7.  $80 \div -4$

8.  $-64 \div -8$

9.  $\frac{72}{-9}$

10.  $\frac{-100}{-5}$

11.  $\frac{-90}{6}$

12.  $\frac{360}{12}$

13.  $\frac{-400}{-25}$

14.  $\frac{-525}{5}$

15.  $\frac{84}{-6}$

16.  $\frac{215}{5}$

**Evaluate each expression if  $a = -2$ ,  $b = 5$ , and  $c = -4$ .**

17.  $-35 \div b$

18.  $54 \div a$

19.  $-56 \div c$

20.  $205 \div b$

21.  $\frac{c}{-2}$

22.  $\frac{b}{5}$

23.  $\frac{2}{a}$

24.  $\frac{-4}{c}$

25.  $\frac{-28}{c}$

26.  $\frac{ac}{-8}$

27.  $\frac{bc}{a}$

28.  $\frac{250}{ab}$

**Find the average (mean) of each group of numbers.**

29. 23, 20, 27, 18

30. -8, 9, 4, 0, 2, -1

31. 17, 21, 4

32. -20, -15, -12, -1, 1, 12, 15, 20

33. -7, -3, -9, 0, 21, -2, -14

**34. TESTS** Miranda earned scores of 84, 91, 95, 78, and 92 on her math tests. Find her average (mean) score.

**35. TEMPERATURE** At noon on Friday, the temperature was  $0^{\circ}\text{F}$ . Six hours later the temperature was  $-18^{\circ}\text{F}$ . On average, what was the temperature change per hour?

**36. BUSINESS** The architecture firm of Stuart and Maxwell, Ltd., had monthly profits of \$1200, \$755,  $-\$450$ , \$210, and  $-\$640$  over 5 months. What was the average profit for those months?

# 2-6

## Practice

### The Coordinate System

Graph and label each point on the coordinate plane. Name the quadrant in which each point is located.

- 1.  $A(8, 6)$
- 2.  $B(-8, 6)$
- 3.  $C(-4, -11)$
- 4.  $D(3, -6)$
- 5.  $E(9, 0)$
- 6.  $F(-4, 1)$
- 7.  $G(-10, -10)$
- 8.  $H(0, -8)$
- 9.  $I(6, -2)$
- 10.  $J(2, 13)$

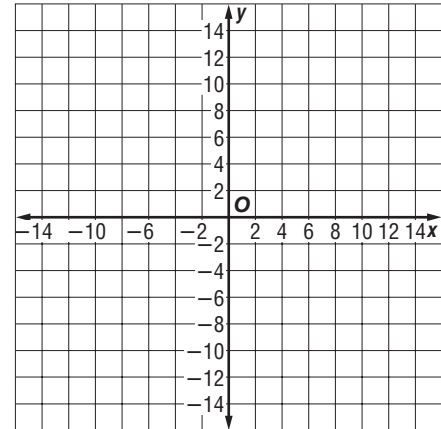

11. **ALGEBRA** Make a table of values and graph six sets of ordered pairs for the equation  $y = 5 - x$ . Describe the graph.

$y = 5 - x$		
$x$	$y$	$(x, y)$

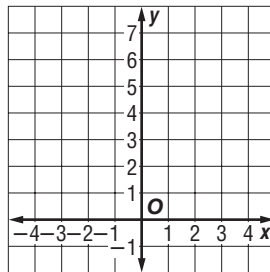

12. **GEOMETRY** On the coordinate plane, draw a rectangle  $ABCD$  with vertices at  $A(1, 4)$ ,  $B(5, 4)$ ,  $C(5, 1)$ , and  $D(1, 1)$ . Then graph and describe the new rectangle formed when you subtract 3 from each coordinate of the vertices in rectangle  $ABCD$ .

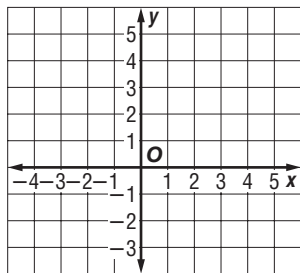

**3-1 Practice*****The Distributive Property***

Use the Distributive Property to write each expression as an equivalent expression. Then evaluate the expression.

1.  $6(80 + 1)$

2.  $7(70 - 4)$

3.  $(300 + 6)4$

4.  $(100 + 10)9$

5.  $5(400 - 90)$

6.  $-8(700 - 3)$

7.  $4(20 - 9)$

8.  $(100 - 3)(-7)$

9.  $-1(75 - 9)$

10.  $14(21 - 11)$

11.  $-25(80 + 2)$

12.  $31(450 - 18)$

Use the Distributive Property to write each expression as an equivalent algebraic expression.

13.  $7(y + 11)$

14.  $-6(t - 1)$

15.  $-8(u - 2)$

16.  $(r + 9)(-4)$

17.  $-1(-h + 5)$

18.  $-2(f + 3)$

19.  $-4(b - 1)$

20.  $1(7 - v)$

21.  $-2(d - 5)$

22.  $22(n + 10)$

23.  $-50(z - 1)$

24.  $-12(g + 12)$

25.  $17(p + 4)$

26.  $(k - 21)(-8)$

27.  $(-32 - s)(-9)$

28.  $-28(a - 5)$

29.  $-20(19 - a)$

30.  $33(d + 4)$

31.  $-18(-q - 5)$

32.  $-16(c + 45)$

33.  $-19(v - 1)$

34.  $-1(r + 27)$

35.  $53(x + 11)$

36.  $-17(-n + 1)$

**37. PLANTS** A planter weighs 2 pounds and holds 3 pounds of soil. Write two equivalent expressions for the total weight of nine planters. Then find the weight.

**38. UNIFORMS** A uniform costs \$42 for the sweater and \$29 for the slacks. Write two equivalent expressions for the total cost of six uniforms. Then find the cost.

**3-2 Practice*****Simplifying Algebraic Expressions*****Simplify each expression.**

1.  $6y - 4 + y$

2.  $8u + 2u - 3u$

3.  $-12 + 5g + 8 - g$

4.  $-21w + 5 + 3w - 1$

5.  $r + r + r + r + r$

6.  $f - 3f + 2 - f + 1$

7.  $-8q + 6 + 5q - 3$

8.  $h + 5h - 3 - 6h$

9.  $2a - 5(a + 1)$

10.  $b - 2(b - 2)$

11.  $9 - t - 3(t + 3)$

12.  $-8 + 5(g + 2) - 2$

13.  $12m + 9 - 2m - 16$

14.  $4(y - 3) + 9 - 3y$

15.  $8a + b - 3a + 4b$

16.  $-11x + 4 + 8x - 4 + 3x$

17.  $-14y + 12(x + y) - 12x$

18.  $19g - 4h + 4 - 20(g - 1)$

19.  $-5(c + d) - 4d + 5c - d$

20.  $(8 - b)(-3) + 6b + 12 - 10b$

21.  $-p + q + 2(p + q) - p - q$

22.  $-55n + 28n + 21n + 7n - n$

23.  $-12z + 4(z - 9) + 30 + z$

24.  $-9 + w - v + 5w + 2v + 5$

25.  $-6(y - 1) + 2y + 7 - y + 4$

26.  $x - 10 + y - 2(x + y) + y$

**Write an expression in simplest form that represents the total amount in each situation.****27. LUNCH** You bought 3 pieces of chicken that cost  $x$  dollars each, a salad for \$3, and a drink for \$1.**28. SOCCER** Sal has scored  $g$  goals this season. Ben has scored four times as many goals as Sal. Chun has scored three fewer goals than Ben.

**3-3 Practice*****Solving Equations by Adding or Subtracting***

Solve each equation. Check your solution.

1.  $z + 6 = -5$

2.  $x - 8 = -3$

3.  $c - 2 = 21$

4.  $v + 9 = 0$

5.  $q + 10 = -30$

6.  $w + 15 = 0$

7.  $z + 12 = -19$

8.  $b - 11 = 8$

9.  $a - 12 = 0$

10.  $r + 11 = 12$

11.  $p + (-9) = 33$

12.  $n - 16 = -16$

13.  $s + 13 = -5$

14.  $t - (-15) = 21$

15.  $r - 14 = -23$

16.  $m + (-3) = 9$

17.  $d - 19 = 1$

18.  $y + 30 = -1$

19.  $u - 21 = 0$

20.  $k - 18 = 2$

21.  $f - 23 = 23$

22.  $g - 24 = -24$

23.  $h + 35 = 7$

24.  $j + 40 = 25$

25.  $x + 3 = -15$

26.  $c + 22 = -27$

27.  $v - 18 = -4$

28.  $b - 41 = -30$

29.  $h - 10 = 19$

30.  $y - (-12) = 0$

31.  $g + 58 = 9$

32.  $n + 29 = 4$

33.  $j + (-14) = 1$

34.  $p - 21 = -2$

35.  $k - (-13) = -8$

36.  $m + 33 = 16$

**37. SAVINGS ACCOUNT** Jhumpa has \$55 in her savings account. This is \$21 more than David. Write and solve an equation to find the amount David has in his savings account.

**38. WEATHER** The temperature fell  $16^\circ$  between noon and 3:00 P.M. At 3:00, the temperature was  $-3^\circ\text{F}$ . Write an equation to determine the temperature at noon.



**3-4 Practice****Solving Equations by Multiplying or Dividing**

Solve each equation. Check your solution.

1.  $8y = 56$

2.  $\frac{w}{4} = 12$

3.  $-3u = -12$

4.  $\frac{r}{-5} = 15$

5.  $9d = -9$

6.  $-8f = 0$

7.  $\frac{n}{-1} = 31$

8.  $\frac{v}{14} = -7$

9.  $-1b = 24$

10.  $-12h = -72$

11.  $\frac{r}{24} = -5$

12.  $\frac{p}{-6} = -3$

13.  $-15x = 90$

14.  $-4g = -20$

15.  $\frac{z}{20} = -1$

16.  $11t = 0$

17.  $23g = -92$

18.  $-7d = -28$

19.  $\frac{m}{-15} = 7$

20.  $9k = -9$

21.  $6w = 0$

22.  $-4r = 120$

23.  $\frac{u}{12} = 1$

24.  $-11q = -99$

25.  $16y = -192$

26.  $\frac{n}{-8} = 0$

27.  $-7j = 84$

28.  $-21p = -231$

**Write and solve an equation for each sentence.**29. The product of a number and  $-6$  is  $-54$ .30. The quotient of a number and  $6$  is  $-14$ .31. **CLASS REPORTS** Each student needs  $12$  minutes to give a report. A class period is  $48$  minutes long. Write and solve an equation to determine the number of students who could give a report in one class period.32. **COOKING** One pound of ground beef makes four hamburger patties. Write and solve an equation to determine how many pounds of beef are needed to make  $36$  hamburgers.

**3-5 Practice****Solving Two-Step Equations**

Solve each equation. Check your solution.

1.  $6p + 22 = 10$

2.  $\frac{r}{3} - 4 = 2$

3.  $5d - 9 = -24$

4.  $21q - 11 = 10$

5.  $\frac{v}{-6} + 1 = 0$

6.  $7h + 20 = -8$

7.  $8k - 40 = 16$

8.  $\frac{w}{2} - 16 = 5$

9.  $\frac{s}{4} - 5 = 1$

10.  $\frac{x}{8} + 7 = 9$

11.  $\frac{z}{10} - 20 = -20$

12.  $\frac{r}{-2} + 11 = 15$

13.  $9q + 10 = 118$

14.  $\frac{n}{5} - 4 = -10$

15.  $6w - 125 = 1$

16.  $\frac{r}{3} - 16 = 2$

17.  $9y - 11 - 5y = 25$

18.  $20 - 15d = 35$

19.  $\frac{u}{-9} - 8 = -4$

20.  $-6h + 4 - 3 + h = 11$

21.  $5p - 4p = 7$

22.  $18 - \frac{x}{3} = -7$

23.  $21 + 9j - 10 = -277$

24.  $12b - 9 + 2b - b = -87$

25.  $1 + \frac{a}{-9} - 4 = 0$

26.  $4w - w - 26 = 19$

27.  $5 - 4y + y - 1 = -23$

**28. RENTAL AGREEMENTS** A furniture rental store charges a down-payment of \$100 and \$75 per month for a table. Hilde paid \$550 to rent the table. Solve  $75n + 100 = 550$  to find the number of months Hilde rented the table.

**29. BUSINESS** At work, Jack must stuff 1000 envelopes with advertisements. He can stuff 12 envelopes in one minute, and he has 112 envelopes already finished. Solve  $1000 = 12n + 112$  to find how many minutes it will take Jack to complete the task.

**3-6 Practice*****Writing Two-Step Equations***

**Translate each sentence into an equation. Then find each number.**

1. Eight less than 7 times a number is  $-29$ .
2. Twenty more than twice a number is 52.
3. The difference between three times a number and 11 is 10.
4. One more than the difference between 18 and seven times a number is  $-9$ .
5. Eight times a number plus 6 less than twice the number is 34.
6. 26 more than the product of a number and 17 is  $-42$ .
7. Twelve less than the quotient of a number and 8 is  $-1$ .

**Solve each problem by writing and solving an equation.**

8. **ANIMAL TRAINING** Last summer, Gary trained 32 more dogs than Zina. Together they trained 126 dogs. How many dogs did Gary train?
9. **SALES** Julius sold five times as many computers as Sam sold last year. In total, they sold 78 computers. How many computers did Julius sell?
10. **TRACK** In one season, Ana ran 18 races. This was four fewer races than twice the number of races Kelly ran. How many races did Kelly run?
11. **BASEBALL** André hit four more home runs than twice the number of home runs Larry hit. Together they hit 10 home runs. How many home runs did André hit?

**3-7 Practice*****Sequences and Equations***

Describe each sequence using words and symbols.

1. 46, 52, 58, 64, ...

2. 5, 13, 21, 29, ...

3. 9, 14, 19, 24, ...

4. 11, 14, 17, 20, ...

5. 3, 5, 7, 9, ...

6. 44, 60, 76, 92, ...

Write an equation that describes each sequence. Then find the indicated term.

7. 20, 33, 46, 59, ...; 17th term

8. 29, 38, 47, 56, ...; 21st term

9. 101, 103, 105, 107, ...; 30th term

10. 64, 67, 70, 73, ...; 44th term

11. 26, 29, 32, 35, ...; 57th term

12. 112, 140, 168, 196, ...; 74th term

**13. RUNNING** Luisa ran 3 miles on the 3rd day of a month, and she repeated her run every 4 days for the rest of the month. What equation describes the sequence of days of that month that Luisa ran?

**14. DEPRECIATION** A new hybrid car costs \$25,000. If it depreciates at \$2,000 of its value each year, find the value of the car over the next 5 years.

**3-8**

**Practice**

*Using Formulas*

1. **AIR TRAVEL** What is the rate, in miles per hour, of a plane that travels 1680 miles in 3 hours?
2. **TRAVEL** A train is traveling at 54 miles per hour. How long will it take to go 378 miles?
3. **SWIMMING** What is the rate, in feet per second, of a swimmer who crosses a 164-foot-long pool in 41 seconds?
4. **BALLOONING** A balloon is caught in a wind traveling at 25 feet per second. If the wind is constant, how long will it take the balloon to travel 1000 feet?

**Find the perimeter and area of each rectangle.**

5.

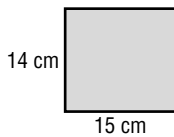

6.

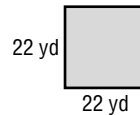

7.

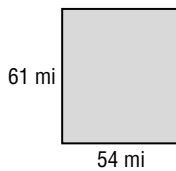

8.

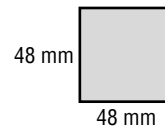

9. a rectangle that is 92 meters long and 18 meters wide
10. a rectangle that is 30 inches long and 29 inches wide

**Find the missing dimension in each rectangle.**

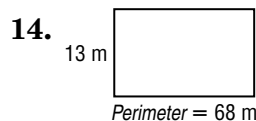
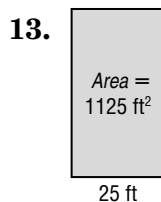
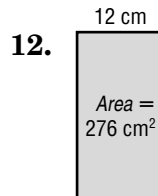
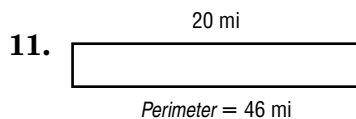

15. **GEOMETRY** The area of a rectangle is 1260 square inches. Its length is 36 inches. Find the width.

**4-1 Practice*****Powers and Exponents***

Write each expression using exponents.

1.  $11 \cdot 11 \cdot 11$

2.  $2 \cdot 2 \cdot 2 \cdot 2 \cdot 2 \cdot 2 \cdot 2 \cdot 2$

3.  $5$

4.  $(-4)(-4)$

5.  $a \cdot a \cdot a \cdot a$

6.  $n \cdot n \cdot n \cdot n \cdot n$

7.  $4 \cdot 4 \cdot 4$

8.  $(b \cdot b)(b \cdot b)(b \cdot b)$

9.  $(-v)(-v)(-v)(-v)$

10.  $x \cdot x \cdot z \cdot z \cdot z$

11.  $2 \cdot 2 \cdot 2 \cdot 2 \cdot 2 \cdot t \cdot t$

12.  $m \cdot m \cdot m \cdot n \cdot p \cdot p$

Express each number in expanded form.

13. 13

14. 1006

15. 17,629

16. 897

Evaluate each expression if  $x = 3$ ,  $y = -2$ , and  $z = 4$ .

17.  $y^x$

18.  $51^0$

19.  $z^2$

20.  $x^2$

21.  $9^x$

22.  $z^2 \cdot 2^2$

23.  $y^5$

24.  $z^2 - y^4$

25.  $x^2 + y^2 + z^2$

26.  $z^2 - x^2$

**FAMILY TREE** For Exercises 27 and 28, refer to the following information.

When examining a family tree, the branches are many. You are generation “now.” One generation ago, your 2 parents were born. Two generations ago, your 4 grandparents were born.

27. How many great-grandparents were born three generations ago?

28. How many “great” grandparents were born ten generations ago?

**4-2 Practice*****Prime Factorization***

Determine whether each number is *prime* or *composite*.

- |       |       |
|-------|-------|
| 1. 11 | 2. 63 |
| 3. 73 | 4. 75 |
| 5. 49 | 6. 69 |
| 7. 53 | 8. 83 |

Write the prime factorization of each number. Use exponents for repeated factors.

- |         |          |
|---------|----------|
| 9. 33   | 10. 24   |
| 11. 72  | 12. 276  |
| 13. 85  | 14. 1024 |
| 15. 95  | 16. 200  |
| 17. 243 | 18. 735  |

Factor each monomial.

- |              |              |
|--------------|--------------|
| 19. $35v$    | 20. $49c^2$  |
| 21. $-14b^3$ | 22. $-81h^2$ |
| 23. $33wz$   | 24. $-56ghj$ |

- 25. NUMBER THEORY** *Twin primes* are a pair of consecutive odd primes, which differ by 2. For example, 3 and 5 are twin primes. Find the twin primes less than 100.  
(*Hint*: There are 8 pairs of twins less than 100.)

**4-3 Practice*****Greatest Common Factor (GCF)*****Find the GCF of each set of numbers or monomials.**

- |                         |                         |
|-------------------------|-------------------------|
| 1. 9, 36                | 2. 42, 60               |
| 3. 16, 60               | 4. 29, 58               |
| 5. 18, 35               | 6. 90, 480              |
| 7. 80, 45               | 8. 700, 200             |
| 9. 17, 85               | 10. 24, 84, 168         |
| 11. 55, 105             | 12. 252, 126            |
| 13. $5p$ , $20p^2$      | 14. $28a$ , $49ab$      |
| 15. $8b$ , $5c$         | 16. $6a^2$ , $18b^2$    |
| 17. $88s^2t$ , $40st^2$ | 18. $42a^2b$ , $60ab^2$ |

**Factor each expression.**

- |                 |                 |
|-----------------|-----------------|
| 19. $10x + 40$  | 20. $8v + 56$   |
| 21. $9t + 9$    | 22. $13m + 39$  |
| 23. $90 + 45n$  | 24. $15p + 60$  |
| 25. $48 + 8r$   | 26. $11z - 55$  |
| 27. $18q - 54$  | 28. $125 - 25h$ |
| 29. $42a - 77$  | 30. $30 + 45s$  |
| 31. $50n + 30$  | 32. $18 + 12d$  |
| 33. $27m + 105$ | 34. $65 - 39b$  |
| 35. $21d - 63$  | 36. $48 + 84m$  |

- 37. SCHOOL TRIP** Thirty-two seventh graders, 48 eighth graders, and 60 ninth graders are taking a ski trip. In order to help students get better acquainted, students from each grade level are to ride each bus. What is the greatest number of buses that can be used if students from each grade level are divided equally among the buses?



**4-4 Practice*****Simplifying Algebraic Fractions***

Write each fraction in simplest form. If the fraction is already in simplest form, write *simplified*.

1.  $\frac{9}{36}$

2.  $\frac{6}{10}$

3.  $\frac{19}{57}$

4.  $\frac{21}{24}$

5.  $\frac{6}{39}$

6.  $\frac{85}{100}$

7.  $\frac{16}{72}$

8.  $\frac{32}{136}$

9.  $\frac{45}{72}$

10.  $\frac{46}{92}$

11.  $\frac{35}{55}$

12.  $\frac{64}{80}$

13.  $\frac{57}{60}$

14.  $\frac{17}{56}$

15.  $\frac{33}{63}$

16.  $\frac{34}{60}$

17.  $\frac{24}{52}$

18.  $\frac{96}{108}$

19.  $\frac{45}{48}$

20.  $\frac{14}{29}$

21.  $\frac{x^3}{x^7}$

22.  $\frac{m^4}{m^5}$

23.  $\frac{a^7}{a^4}$

24.  $\frac{u^5}{u}$

25.  $\frac{21y}{24y}$

26.  $\frac{4q^2}{14q^2}$

27.  $\frac{15x^2}{18x^2}$

28.  $\frac{63c}{126c}$

29.  $\frac{11v^2}{121v}$

30.  $\frac{42b^2}{49}$

31.  $\frac{e^2f^2}{e^3f}$

32.  $\frac{m^2}{p^3}$

33.  $\frac{2a^3b^4}{10a^5b}$

34. **SKI RESORT** A local ski resort is open for business 13 weeks in the winter. Write a fraction in simplest form that represents the fraction of a year the resort is open.

**4-5 Practice*****Multiplying and Dividing Monomials***

Find each product or quotient. Express your answer using exponents.

1.  $4^2 \cdot 4^3$

2.  $9^8 \cdot 9^6$

3.  $7^4 \cdot 7^2$

4.  $13^2 \cdot 13^4$

5.  $(-8)^5(-8)^3$

6.  $(-21)^9(-21)^5$

7.  $t^9 \cdot t^3$

8.  $h^4 \cdot h^{13}$

9.  $(m^6)(m^6)$

10.  $(u^{11})(u^{10})$

11.  $(-r)^7(-r)^{20}$

12.  $(-w)(-w)^9$

13.  $4d^5 \cdot 8d^6$

14.  $7j^{50} \cdot 6j^{50}$

15.  $-5b^9 \cdot 6b^2$

16.  $12^1 \cdot 12^2$

17.  $\frac{6^{11}}{6^3}$

18.  $\frac{15^3}{15^2}$

19.  $\frac{9^9}{9^7}$

20.  $\frac{18^4}{18^4}$

21.  $\frac{(-7)^6}{(-7)^5}$

22.  $\frac{95^{21}}{95^{18}}$

23.  $\frac{v^{30}}{v^{20}}$

24.  $\frac{n^{19}}{n^{11}}$

25. the product of five cubed and five to the fourth power

26. the quotient of eighteen to the ninth power and eighteen squared

27. the product of  $z$  cubed and  $z$  cubed

28. the quotient of  $x$  to the fifth power and  $x$  cubed

29. **SOUND** Decibels are units used to measure sound. The softest sound that can be heard is rated as 0 decibels (or a relative loudness of 1). Ordinary conversation is rated at about 60 decibels (or a relative loudness of  $10^6$ ). A rock concert is rated at about 120 decibels (or a relative loudness of  $10^{12}$ ). How many times greater is the relative loudness of a rock concert than the relative loudness of ordinary conversation?

**4-6 Practice*****Negative Exponents***

Write each expression using a positive exponent.

1.  $7^{-8}$

2.  $10^{-6}$

3.  $23^{-1}$

4.  $(-5)^{-2}$

5.  $(-18)^{-10}$

6.  $m^{-99}$

7.  $(-1)^{-12}$

8.  $c^{-6}$

9.  $p^{-5}$

10.  $g^{-17}$

11.  $5z^{-4}$

12.  $3t^{-1}$

Write each fraction as an expression using a negative exponent.

13.  $\frac{1}{2^{10}}$

14.  $\frac{1}{29^3}$

15.  $\frac{1}{4^4}$

16.  $\frac{1}{39}$

17.  $\frac{1}{81^7}$

18.  $\frac{1}{m^4}$

19.  $\frac{1}{x^3}$

20.  $\frac{1}{a^2}$

21.  $\frac{1}{49}$

22.  $\frac{1}{8}$

23.  $\frac{1}{144}$

24.  $\frac{1}{169}$

Evaluate each expression if  $x = 3$ ,  $y = -2$ , and  $z = 4$ .

25.  $x^{-4}$

26.  $y^{-2}$

27.  $y^{-5}$

28.  $z^{-4}$

29.  $5^y$

30.  $10^y$

31.  $3z^{-1}$

32.  $z^y$

33.  $(xz)^{-2}$

34. **HAIR** Hair grows at a rate of  $\frac{1}{64}$  inch per day. Write this number using negative exponents.

**4-7 Practice****Scientific Notation**

Express each number in standard form.

- |                           |                           |
|---------------------------|---------------------------|
| 1. $2.4 \times 10^4$      | 2. $9.0 \times 10^3$      |
| 3. $4.385 \times 10^7$    | 4. $1.03 \times 10^8$     |
| 5. $3.05 \times 10^2$     | 6. $5.11 \times 10^{10}$  |
| 7. $6.000032 \times 10^6$ | 8. $1.0 \times 10^1$      |
| 9. $8.75 \times 10^5$     | 10. $8.49 \times 10^{-2}$ |
| 11. $7.1 \times 10^{-6}$  | 12. $1.0 \times 10^{-3}$  |
| 13. $4.39 \times 10^{-7}$ | 14. $1.25 \times 10^{-4}$ |

Express each number in scientific notation.

- |                       |             |
|-----------------------|-------------|
| 15. 40,000            | 16. 16      |
| 17. 876,000,000       | 18. 4500    |
| 19. 151               | 20. 0.00037 |
| 21. 83,000,000        | 22. 919,100 |
| 23. 5,000,000,000,000 | 24. 0.13    |
| 25. 0.0000007         | 26. 0.0067  |

**NIAGARA FALLS** For Exercises 27 and 28, use the following information.

Every minute, 840,000,000,000 drops of water flow over Niagara Falls.

27. Write this number in scientific notation.
28. How many drops flow over the falls in a day?

**5-1 Practice****Writing Fractions as Decimals**

Write each fraction or mixed number as a decimal. Use a bar to show a repeating decimal.

1.  $\frac{3}{5}$

2.  $\frac{1}{8}$

3.  $\frac{9}{11}$

4.  $-\frac{3}{16}$

5.  $\frac{3}{40}$

6.  $\frac{8}{11}$

7.  $\frac{5}{12}$

8.  $\frac{1}{3}$

9.  $\frac{7}{9}$

10.  $-\frac{11}{15}$

11.  $-\frac{12}{16}$

12.  $\frac{13}{60}$

13.  $\frac{1}{45}$

14.  $-\frac{5}{24}$

15.  $\frac{13}{20}$

16.  $\frac{17}{18}$

17.  $-11\frac{1}{4}$

18.  $23\frac{5}{11}$

19.  $-18\frac{2}{3}$

20.  $5\frac{7}{8}$

Replace each  $\bullet$  with  $<$ ,  $>$ , or  $=$  to make a true sentence.

21.  $-\frac{13}{2} \bullet -6.4$

22.  $\frac{6}{7} \bullet \frac{5}{6}$

23.  $-0.75 \bullet -\frac{15}{20}$

24.  $-4\frac{3}{8} \bullet -4.40$

25.  $\frac{7}{8} \bullet \frac{8}{9}$

26.  $-\frac{33}{100} \bullet -0.\bar{3}$

27. Order  $\frac{4}{9}$ ,  $\frac{444}{1000}$ , and  $0.4$  from least to greatest.

28. Order  $-\frac{8}{9}$ ,  $-\frac{8}{10}$ , and  $-0.\bar{80}$  from least to greatest.

29. **OPINION** In a school survey, 787 out of 1000 students preferred hip-hop music to techno. Is this figure more or less than  $\frac{7}{9}$  of those surveyed? Explain.

**5-2 Practice*****Rational Numbers*****Write each number as a fraction.**

1. 29

2. 0

3.  $3\frac{7}{8}$

4. -47

5.  $-5\frac{6}{7}$

6.  $4\frac{3}{20}$

7.  $-7\frac{2}{15}$

8.  $10\frac{2}{9}$

**Write each decimal as a fraction or mixed number in simplest form.**

9. 0.32

10. 0.42

11.  $0.\overline{8}$

12.  $-6.\overline{3}$

13. 0.91

14. 17.875

15. -0.666...

16. 0.07

17.  $9.\overline{7}$

18. 7.75

19. 0.525

20. -8.26

21.  $6.\overline{5}$

22. -4.12

23. 13.006

24.  $3.\overline{34}$

**Identify all sets to which each number belongs (W = whole numbers, I = integers, Q = rational numbers).**

25. 15

26.  $-3.\overline{8}$

27. -5.075

28.  $\frac{50}{25}$

29.  $\pi$

30.  $-\frac{4}{2}$

31. **BOTANY** The smallest flowering plant is the flowering aquatic duckweed found in Australia. It is 0.0236 inch long and 0.0129 inch wide. Write these dimensions as fractions in simplest form.

**5-3 Practice****Multiplying Rational Numbers**

Find each product. Write in simplest form.

1.  $\frac{3}{4} \cdot \frac{2}{3}$

2.  $\frac{3}{7} \cdot \frac{21}{39}$

3.  $-\frac{3}{4} \cdot \frac{10}{27}$

4.  $\frac{11}{14} \cdot \frac{7}{33}$

5.  $-\frac{18}{24} \cdot \frac{3}{4}$

6.  $\frac{9}{10} \cdot \frac{20}{21}$

7.  $-50 \cdot \frac{3}{1000}$

8.  $\frac{16}{17} \cdot \left(-\frac{5}{8}\right)$

9.  $-\frac{1}{2} \cdot \left(-\frac{20}{27}\right)$

10.  $-\frac{14}{15} \cdot \left(-\frac{10}{28}\right)$

11.  $4\frac{4}{7} \cdot 9\frac{1}{3}$

12.  $-2\frac{14}{25} \cdot 4\frac{3}{8}$

13.  $4\frac{1}{8} \cdot \left(-1\frac{5}{11}\right)$

14.  $-5 \cdot \frac{17}{25}$

15.  $2\frac{9}{10} \cdot 1\frac{1}{5}$

16.  $\frac{6m}{13} \cdot \frac{2}{mn}$

17.  $\frac{p}{3} \cdot \frac{1}{q}$

18.  $\frac{2u}{v^2} \cdot \frac{3}{u}$

19.  $\frac{4x}{3y} \cdot \frac{9y}{2x}$

20.  $\frac{2a}{b} \cdot \frac{c}{2d}$

21.  $\frac{rs}{9t} \cdot \frac{3}{s^2}$

22.  $2x \cdot \frac{1}{4x^2}$

23.  $\frac{x^2}{4y} \cdot \frac{16y^2}{3x}$

24.  $\frac{2}{r} \cdot \frac{3}{r}$

25. **WEIGHTS** How many ounces are in  $3\frac{3}{4}$  pounds?26. **FOOTBALL** The total length of 17.6 football fields equals 1 mile. How long is a mile?  
(Hint: length of a football field = 100 yd)27. **AIRPLANES** The fastest airliner, the Concorde, has the capability of cruising at speeds of up to 1450 mph. While cruising at this top speed, how far would the Concorde travel in  $2\frac{1}{2}$  hours?

**5-4 Practice*****Dividing Rational Numbers***

Find each quotient. Write in simplest form.

1.  $\frac{1}{2} \div \frac{1}{10}$

2.  $-\frac{3}{8} \div \frac{9}{24}$

3.  $-\frac{15}{16} \div \frac{7}{12}$

4.  $\frac{17}{20} \div \left(-\frac{3}{10}\right)$

5.  $-\frac{3}{8} \div \left(-\frac{3}{9}\right)$

6.  $\frac{25}{32} \div \frac{15}{56}$

7.  $0 \div \frac{17}{18}$

8.  $-1\frac{1}{2} \div \frac{1}{4}$

9.  $\frac{8}{9} \div \frac{22}{81}$

10.  $8\frac{4}{9} \div 2\frac{1}{9}$

11.  $4\frac{3}{5} \div \frac{2}{5}$

12.  $-\frac{100}{63} \div \frac{10}{81}$

13.  $18\frac{1}{3} \div \left(-4\frac{1}{6}\right)$

14.  $-3\frac{2}{9} \div \frac{4}{27}$

15.  $-2\frac{5}{6} \div \frac{3}{51}$

16.  $4\frac{11}{12} \div 4\frac{5}{6}$

17.  $\frac{2x}{3} \div \frac{1}{9}$

18.  $\frac{a}{4} \div \frac{a}{8}$

19.  $\frac{4k}{5} \div \frac{25}{2k}$

20.  $\frac{ab}{8} \div \frac{b}{a}$

21.  $\frac{2c}{b} \div \frac{4a}{b}$

22.  $\frac{y}{x} \div y^2$

23.  $\frac{3st}{r} \div \frac{4t}{r}$

24.  $\frac{a^2}{b^2} \div \frac{c^2}{b^2}$

25.  $-\frac{2x}{y} \div \frac{4}{y}$

26.  $\frac{m^2}{2np} \div \frac{n}{4p}$

27. Evaluate  $x \div y$  if  $x = 3\frac{1}{2}$  and  $y = \frac{3}{4}$ .

28. Evaluate  $w \div z$  if  $w = \frac{6}{7}$  and  $z = 3$ .

29. **TRAVEL** What is the average speed that Robin must drive to reach her friend's house 170 miles away in  $2\frac{1}{2}$  hours?

30. **SEWING** How many choir robes can be made from  $20\frac{1}{4}$  yards of fabric if each robe needs  $1\frac{1}{8}$  yards?



**5-5 Practice****Adding and Subtracting Like Fractions**

Find each sum or difference. Write in simplest form.

1.  $\frac{5}{7} + \frac{2}{7}$

2.  $\frac{5}{11} - \frac{1}{11}$

3.  $\frac{13}{20} - \frac{3}{20}$

4.  $\frac{5}{16} + \frac{15}{16}$

5.  $-\frac{19}{40} + \frac{21}{40}$

6.  $-\frac{7}{9} - \frac{4}{9}$

7.  $\frac{14}{23} - \frac{16}{23}$

8.  $\frac{25}{36} + \left(-\frac{7}{36}\right)$

9.  $\frac{21}{25} + \frac{9}{25}$

10.  $10\frac{4}{7} + 11\frac{5}{7}$

11.  $9\frac{3}{8} + 4\frac{1}{8}$

12.  $-8\frac{7}{10} + 2\frac{3}{10}$

13.  $23\frac{17}{20} - 4\frac{7}{20}$

14.  $22\frac{3}{8} - 18\frac{5}{8}$

15.  $7\frac{9}{10} + 3\frac{3}{10}$

16.  $6\frac{1}{6} - 3\frac{5}{6}$

17.  $5\frac{1}{4} + 3\frac{1}{4} + 9\frac{3}{4}$

18.  $6\frac{7}{8} + \left(-7\frac{3}{8}\right)$

19.  $\frac{h}{6} + \frac{4h}{6}$

20.  $\frac{5c}{22} + \frac{5c}{22}$

21.  $\frac{35}{d} - \frac{17}{d}, d \neq 0$

22.  $\frac{4r}{9} + \frac{5r}{9}$

23.  $\frac{6s}{t} + \frac{s}{t}$

24.  $\frac{5p}{9} - \frac{4p}{9}$

25.  $\frac{6r^2}{s^2} + \frac{5r^2}{s^2}$

26.  $4\frac{5}{7a} - 2\frac{3}{7a}$

27. **PICTURE FRAMING** Matt plans to paste a picture that is  $6\frac{7}{8}$  inches wide on a sheet of paper that is  $8\frac{4}{8}$  inches wide. If he wants to have at least  $\frac{5}{8}$  inch of margin on each side, will the picture fit? Explain.

**5-6 Practice****Least Common Multiple**

Find the least common multiple (LCM) of each pair of numbers or monomials.

1. 10, 12

2. 9, 15

3. 20, 24

4. 30, 45

5. 14, 15

6. 35, 75

7. 12, 63

8. 48, 20

9.  $15q$ ,  $3q^2t$

10. 9,  $18b$

11.  $8y$ ,  $10y^2$

12.  $20p$ ,  $100p^2$

Find the least common denominator (LCD) of each pair of fractions.

13.  $\frac{1}{2}$ ,  $\frac{2}{3}$

14.  $\frac{9}{14}$ ,  $\frac{3}{7}$

15.  $\frac{5}{12}$ ,  $\frac{8}{15}$

16.  $\frac{13}{18}$ ,  $\frac{6}{45}$

17.  $\frac{5}{32}$ ,  $\frac{17}{24}$

18.  $\frac{1}{x}$ ,  $\frac{3}{xy}$

19.  $\frac{3}{8m}$ ,  $\frac{1}{4mn^2}$

20.  $\frac{12}{25ab}$ ,  $\frac{3}{100b^2}$

Replace each  $\bullet$  with  $<$ ,  $>$ , or  $=$  to make a true sentence.

21.  $\frac{2}{5} \bullet \frac{7}{15}$

22.  $\frac{4}{9} \bullet \frac{8}{18}$

23.  $\frac{9}{36} \bullet \frac{4}{8}$

24.  $\frac{4}{8} \bullet \frac{5}{9}$

25.  $\frac{4}{18} \bullet \frac{3}{15}$

26.  $\frac{3}{28} \bullet \frac{5}{32}$

27. **VOTING** During a student council meeting,  $\frac{7}{12}$  of the members voted to hold a bake sale.If a  $\frac{2}{3}$  vote is required to pass, will a bake sale be held?

**5-7 Practice****Adding and Subtracting Unlike Fractions**

Find each sum or difference. Write in simplest form.

1.  $\frac{9}{10} + \frac{1}{2}$

2.  $\frac{7}{8} + \frac{1}{10}$

3.  $-\frac{3}{4} + \frac{5}{16}$

4.  $\frac{4}{5} - \frac{2}{6}$

5.  $\frac{5}{8} - \frac{3}{16}$

6.  $\frac{1}{3} + \frac{5}{36}$

7.  $\frac{7}{10} - \frac{14}{100}$

8.  $\frac{17}{21} - \frac{4}{6}$

9.  $\frac{11}{14} - \frac{1}{6}$

10.  $\frac{4}{15} - \left(-\frac{3}{12}\right)$

11.  $\frac{7}{15} + \frac{3}{6}$

12.  $-\frac{7}{8} + \frac{9}{10}$

13.  $10\frac{1}{2} + 7\frac{1}{3}$

14.  $7\frac{1}{2} - 2\frac{7}{10}$

15.  $8\frac{1}{6} + 5\frac{3}{4}$

16.  $7\frac{7}{12} - 5\frac{1}{3}$

17.  $6\frac{4}{5} + \left(-2\frac{3}{8}\right)$

18.  $16\frac{3}{5} + 3\frac{11}{15}$

19.  $18\frac{3}{5} - 7\frac{1}{4}$

20.  $12\frac{2}{7} - 3\frac{5}{6}$

21.  $2\frac{5}{8} + 6\frac{3}{4}$

22.  $29\frac{8}{33} + \left(-3\frac{1}{3}\right)$

23.  $-6\frac{2}{7} - 5\frac{3}{14}$

24.  $-16\frac{2}{7} - 3\frac{20}{21}$

25.  $-10\frac{1}{9} + 9\frac{7}{45}$

26.  $\frac{1}{3} + \frac{5}{6} + \frac{1}{2}$

27.  $9\frac{2}{7} - 11\frac{18}{21}$

28.  $-17\frac{2}{3} - \left(-5\frac{4}{18}\right)$

29.  $11\frac{3}{16} - 5\frac{1}{12}$

30.  $\frac{64}{143} - \frac{21}{208}$

31. **SEWING** The inseam on Juan's pants is  $34\frac{1}{4}$  inches. If he has them shortened by  $2\frac{7}{8}$  inches, what is the new length?

**5-8 Practice****Solving Equations With Rational Numbers**

Solve each equation. Check your solution.

1.  $y + 6.1 = 19.5$

2.  $m + 5.8 = 19.9$

3.  $8.7 + x = 9.6$

4.  $t - 4.82 = 5.36$

5.  $\frac{1}{2} + x = \frac{4}{7}$

6.  $-11 = x - 8$

7.  $\frac{11}{12} = \frac{3}{8} + v$

8.  $-2.9 = m - 3.6$

9.  $\frac{x}{5.09} = 0$

10.  $6 = \frac{3}{7} + u$

11.  $\frac{4}{5}x = \frac{16}{25}$

12.  $\frac{q}{3.2} = -20$

13.  $9\frac{3}{4} = r - 6\frac{2}{9}$

14.  $\frac{14}{25} = v + \frac{1}{2}$

15.  $0.8p = 6$

16.  $y + 2\frac{2}{5} = 5\frac{4}{15}$

17.  $10 = \frac{5}{9}u$

18.  $6\frac{2}{3} = n - 10\frac{1}{9}$

19.  $b - \frac{7}{10} = -\frac{1}{4}$

20.  $-5.2 = 20.8c$

21.  $\frac{3}{8} + g = \frac{7}{12}$

22.  $3\frac{3}{4} + h = -8\frac{1}{2}$

23.  $9 = -\frac{1}{4}w$

24.  $1\frac{1}{2} = 6q$

25. **ELECTRICITY** If a television uses  $\frac{3}{20}$  kilowatt-hours of electricity per hour, how long will it take to use 14 kilowatt-hours of electricity?

26. **COMPUTER DISKS** Mr. Rosenthal bought 15 computer disks and a carrying case for \$28.50. If the carrying case cost \$6.75, what was the cost of each disk?

# 5-9 Practice

## Measures of Central Tendency

Find the mean, median, and mode for each set of data. If necessary, round to the nearest tenth.

1. 4, 6, 12, 5, 8

2. 16, 18, 15, 16, 21, 16

3. 55, 46, 50, 42, 39

4. 17, 16, 13, 17, 17, 10, 10, 13, 10

5. 25, 25, 25, 20

6. 3.1, 4.5, 4.5, 4.3, 6.0, 3.2

Find the mean, median, and mode for each set of data. If necessary, round to the nearest tenth.

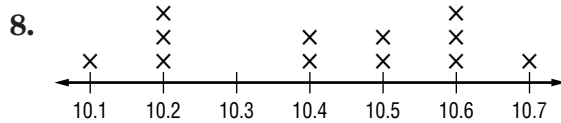
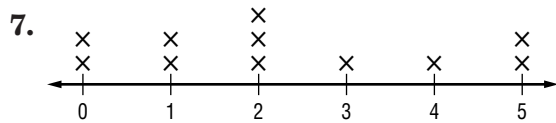

9. **TORNADOES** The table below shows the number of tornadoes reported in the United States from 1980–1990. Find the mean, median, and mode for the number of tornadoes.

Year	1980	1981	1982	1983	1984	1985	1986	1987	1988	1989	1990
Number of Tornadoes	866	783	1046	931	907	684	764	656	702	858	1132

Source: *The Universal Almanac*

**6-1 Practice*****Ratios and Rates***

Express each ratio as a fraction in simplest form.

1. 56 pencils out of 64 erasers
2. 25 calculators to 20 students
3. 36 cassettes to 60 CDs
4. 18 minnows to 27 fish
5. 6 pounds to 256 ounces
6. 5 hours to 720 minutes
7. 9 gallons to 48 quarts
8. 24 feet to 30 yards

Express each ratio as a unit rate. Round to the nearest tenth or nearest cent, if necessary.

9. \$4.60 for 5 cans of soup
10. \$51 for a box of 75 tiles
11. 652 miles in 9 days
12. 116 meters in 12 seconds
13. 176 new employees in 22 years
14. 34 yards for 6 costumes
15. 55 pages in 25 minutes
16. \$3015 from 36 people

Convert each rate using dimensional analysis.

17.  $18 \text{ m/min} = \underline{\quad? \quad} \text{ cm/s}$
18.  $5.7 \text{ gal/h} = \underline{\quad? \quad} \text{ c/min}$
19.  $264 \text{ yd/s} = \underline{\quad? \quad} \text{ mi/h}$
20.  $2 \text{ qt/min} = \underline{\quad? \quad} \text{ gal/h}$
21.  $99 \text{ in./s} = \underline{\quad? \quad} \text{ mi/day}$  (1 day = 24 h)
22.  $154 \text{ mi/h} = \underline{\quad? \quad} \text{ in./s}$

- 23. TRACK AND FIELD** Rita sprinted 77 feet in 10 seconds. How many miles per hour is this?

**6-2 Practice*****Proportional and Nonproportional Relationships***

Determine whether the set of numbers in each table are proportional.

1. 

<b>Cups of Rice</b>	1	2	2.5	3
<b>Cups of Water</b>	1.5	3	3.75	4.5

2. 

<b>Miles driven</b>	1	2	6	9
<b>Toll fare</b>	\$1.07	\$1.14	\$1.42	\$1.63

For Exercises 3 and 4, write and solve an equation.

3. **JOBS** Sharif started a new job working 15 hours a week. After how many weeks will he have worked a total of 75 hours?

4. **GARDENING** During its first 50 days of growth, a sunflower grows about 4 cm per day. Using this rate, after how many days will a sunflower be 60 cm tall?

For Exercises 5–6, complete each table. Determine whether the pattern forms a proportion.

5. **TEXT MESSAGING** It costs Victoria \$0.10 to send a text message.

<b>Number of Messages</b>	4				
<b>Cost</b>					

6. **WATER CONSUMPTION** Water flows out of a kitchen faucet at about 1.5 gallons per minute.

<b>Minutes</b>	0.5				
<b>Gallons of Water</b>					

7. **COOKING** The amount of time it takes to cook a turkey increases with the weight of the turkey. It is recommended that you cook a 10 lb turkey for 3 hours. An extra 12 minutes of cooking time is necessary for each additional pound of turkey. Is the cooking time proportional to the weight of the turkey? Explain your reasoning.

**6-3 Practice****Using Proportions**

Determine whether each pair of ratios forms a proportion.

1.  $\frac{5}{8}, \frac{20}{32}$

2.  $\frac{12}{28}, \frac{27}{63}$

3.  $\frac{8}{50}, \frac{1}{43}$

4.  $\frac{40}{48}, \frac{56}{42}$

5.  $\frac{6.4}{16}, \frac{32}{80}$

6.  $\frac{12}{18}, \frac{90}{135}$

7.  $\frac{21}{24}, \frac{56}{64}$

8.  $\frac{9}{16}, \frac{3}{4}$

9.  $\frac{12}{32}, \frac{8}{3}$

10.  $\frac{2.6}{4}, \frac{4.6}{8}$

11.  $\frac{5.1}{1.7}, \frac{7.5}{2.5}$

12.  $\frac{8.5}{25}, \frac{17}{50}$

**ALGEBRA** Solve each proportion.

13.  $\frac{n}{12} = \frac{6}{18}$

14.  $\frac{8}{v} = \frac{56}{105}$

15.  $\frac{15}{35} = \frac{s}{7}$

16.  $\frac{24}{30} = \frac{8}{w}$

17.  $\frac{c}{28} = \frac{5}{7}$

18.  $\frac{3}{r} = \frac{39}{65}$

19.  $\frac{9}{15} = \frac{m}{25}$

20.  $\frac{7.5}{6.0} = \frac{3.6}{x}$

21.  $\frac{12}{25} = \frac{u}{40}$

22.  $\frac{1}{a} = \frac{33}{132}$

23.  $\frac{f}{5} = \frac{16}{40}$

24.  $\frac{r}{6.5} = \frac{0.2}{1.3}$

25.  $\frac{30}{14} = \frac{k}{1.54}$

26.  $\frac{3.5}{7.2} = \frac{k}{57.6}$

27.  $\frac{2.1}{42} = \frac{7}{t}$

28. **FOOD** Gayle is making fruit punch that consists of 2 quarts of juice and 1 quart of soda water. How much soda water does she need if she has 5 quarts of juice?



**6-4 Practice****Scale Drawings and Models**

On a map, the scale is 5 centimeters = 2 kilometers. Find the missing distances.

	Location	Map Distance	Actual Distance
1.	Town A to Town B	10 cm	
2.	Town A to Town C		10 km
3.	Town A to Town D		5.6 km
4.	Town A to Town E	2 cm	
5.	Town A to Town F	0.5 cm	
6.	Town A to Town G		3.2 km
7.	Town A to Town H	0.25 cm	
8.	Town A to Town I		2.4 km
9.	Town A to Town J		0.04 km
10.	Town A to Town K	1 cm	
11.	Town A to Town L	2.5 cm	
12.	Town A to Town M		0.48 km

13. Refer to Exercises 1–12. What is the scale factor?
14. What is the scale factor if the scale is 15 inches = 1 yard?
15. **STRUCTURES** A barn is 50 feet wide by 80 feet long. Make a scale drawing of the barn that has a scale of  $\frac{1}{2}$  inch = 10 feet.
16. **PHOTOGRAPHY** A man in a photograph is 1.5 inches in height. If the man is 6 feet tall, what is the scale?

**6-5 Practice*****Fractions, Decimals, and Percents***

Express each percent as a fraction or mixed number in simplest form and as a decimal.

1. 35%

2.  $8\frac{5}{6}\%$

3.  $10\frac{1}{2}\%$

4. 8.4%

5. 500%

6. 32%

7. 80%

8.  $\frac{1}{8}\%$

9. 65%

10. 48.5%

11. 0.15%

12. 0.9%

13. 2.5%

14.  $25\frac{1}{3}\%$

15.  $\frac{1}{20}\%$

16. 820%

Express each decimal or fraction as a percent. Round to the nearest tenth percent, if necessary.

17. 0.95

18. 0.255

19. 0.7

20. 8.75

21. 0.0048

22. 0.06

23. 19.8

24. 0.54

25. 0.27

26. 0.802

27. 0.0007

28. 71

29.  $\frac{33}{40}$

30.  $\frac{9}{32}$

31.  $\frac{3}{8}$

32.  $\frac{11}{4}$

33.  $\frac{35}{8}$

34.  $\frac{1}{5}$

35.  $\frac{14}{25}$

36.  $\frac{4}{11}$

**37. SURVEYS** In a survey, 44% of the people said they voted for Mr. Johnson, while  $\frac{2}{5}$  of the people said they voted for Ms. Smith. Which group is larger? Explain.

**6-6 Practice*****Using the Percent Proportion***

Use the percent proportion to solve each problem. Round to the nearest tenth.

1. 128 is what percent of 640?
2. What percent of 21 is 28?
3. 3.4 is what percent of 5?
4. What percent of 930 is 720?
5. 15 is what percent of 120?
6. What percent of 24 is 21?
7. 36 is what percent of 40?
8. What percent of 48 is 0.6?
9. 12 is 80% of what number?
10. 15 is 4% of what number?
11. 33 is 90% of what number?
12. 0.24 is 36% of what number?
13. 19 is 10% of what number?
14. 49 is 77% of what number?
15. 42 is 7.5% of what number?
16. 65 is 5% of what number?
17. 27.5 is 2% of what number?
18. What is 15.8% of 21?
19. What is 65% of 441.1?
20. What is 0.4% of 82?
21. What is 7% of 329.8?
22. What is 88% of 1?
23. What is 35% of 20?
24. What is 20% of 35?
25. **PAINT** About 42% of a paint mix is white. A painter orders 18 gallons of the paint mix. How much of it is white?

**6-7 Practice*****Finding Percents Mentally*****Find the percent of each number mentally.**

- |                              |                            |                             |
|------------------------------|----------------------------|-----------------------------|
| 1. 10% of 812                | 2. 50% of 1044             | 3. 40% of 25                |
| 4. 20% of 45                 | 5. $62\frac{1}{2}\%$ of 80 | 6. 80% of 15                |
| 7. 30% of 400                | 8. 75% of 880              | 9. $16\frac{2}{3}\%$ of 72  |
| 10. $33\frac{1}{3}\%$ of 150 | 11. 60% of 2500            | 12. $37\frac{1}{2}\%$ of 48 |
| 13. 25% of 244               | 14. 900% of 3              | 15. 150% of 260             |

**Estimate.**

- |                            |                            |                            |
|----------------------------|----------------------------|----------------------------|
| 16. 31% of 62              | 17. 65% of 83              | 18. 87% of 850             |
| 19. 32% of 26              | 20. 47% of 213             | 21. 22% of 536             |
| 22. 68% of 12              | 23. 11% of 29              | 24. 78% of 4               |
| 25. $\frac{1}{2}\%$ of 381 | 26. $\frac{1}{6}\%$ of 567 | 27. $\frac{2}{3}\%$ of 856 |
| 28. 210% of 425            | 29. 153% of 801            | 30. 689% of 2981           |
31. **MONEY** Last week a waitress made \$204 in tips. This week she made 135% of that. How much did she make this week?

**6-8 Practice*****Using Percent Equations***

Solve each problem using the percent equation.

1. What is 5% of 224?
2. What is 18% of 65?
3. What is 63% of 300?
4. What is 40% of 980?
5. What is 18% of 650?
6. Find 2% of 820.
7. Find 75% of 312.
8. Find 312% of 75.
9. Find 5.6% of 1050.
10. Find 21.4% of 855.
11. 52.3 is what percent of 1046?
12. 48 is what percent of 75?
13. 100 is what percent of 250?
14. 96 is what percent of 400?
15. 10 is what percent of 625?
16. 49.8 is what percent of 415?
17. 0.4 is what percent of 5?
18. 157 is what percent of 2512?
19. 1206 is what percent of 8040?
20. 63 is what percent of 60?
21. 13 is 50% of what number?
22. 121 is 22% of what number?
23. 11 is 4% of what number?
24. 438 is 24% of what number?
25. 612 is 25% of what number?
26. 960 is 30% of what number?
27. 3570 is 42% of what number?
28. 8 is 1% of what number?
29. **SHOPPING** A jacket is on sale at 15% off the original price of \$68.00. What is the sale price?

**6-9 Practice*****Percent of Change***

State whether each change is a *percent of increase* or a *percent of decrease*. Then find the percent of change. Round to the nearest tenth, if necessary.

1. from 4 m to 5 m
2. from 75 minutes to 100 minutes
3. from \$9.25 to \$6.50
4. from 45 quarts to 8 quarts
5. from 21 mm to 13 mm
6. from \$457 to \$1000
7. from \$39.50 to \$40.00
8. from 9 students to 856 students
9. from 24 kittens to 7 kittens
10. from 15 songs to 105 songs
11. from 31 mph to 25 mph
12. from 4 paintings to 13 paintings
13. from 55 teachers to 41 teachers
14. from 9780 birds to 8011 birds
15. from 524 sales to 315 sales
16. from 28 houses to 460 houses
17. from 2 miles to 10 miles
18. from 1000 voters to 840 voters
19. from 3 lizards to 21 lizards
20. from 300 horses to 2100 horses
21. from 25 disks to 22 disks
22. from 250 movies to 220 movies
23. from \$34 to \$31
24. from \$3400 to \$3100
25. **COOKIES** On Tuesday, a baker sold 132 cookies. On Wednesday, she sold 108 cookies. Find the percent of change to the nearest tenth of a percent.

**6-10 Practice*****Using Sampling to Predict***

Identify each sample as *biased* or *unbiased* and describe its type. Explain your reasoning.

- To determine how many people in a town support a new tax levy, 200 people are randomly selected from a phone book and then surveyed over the phone.
- To determine the number of households in a town that recycle, 40 households from the same street are polled.
- To determine the usual demand of a Web site, the number of users currently visiting the Web site is recorded every hour.

- ANALYZE GRAPHS** The yearbook staff wanted to find out how many students would buy a yearbook. So, the staff surveyed 15 students who were in the school library after school. The results are in the graph. Is this sampling method valid? If so, about how many of the 1287 students in the school will buy yearbooks?

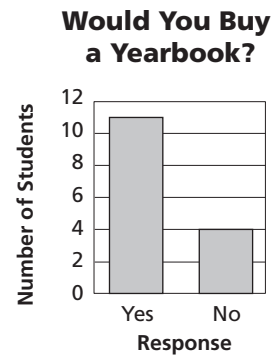

- LIBRARIES** A library would like to see how many of its patrons would be interested in regularly checking out books from an enlarged print section. They randomly surveyed 200 patrons and 6 patrons responded that they would regularly check out books from an enlarged print section. If the library has a total of 3200 patrons, how many people can they expect to regularly check out books from an enlarged print section?

# 7-1

## Practice Functions

Determine whether each relation is a function. Explain.

1.  $\{(4, -5), (0, -9), (1, 0), (7, 0)\}$                       2.  $\{(5, -12), (-1, -2), (8, -5), (4, -2), (3, -5)\}$
3.  $\{(-2, -3), (6, -8), (4, 2), (6, -5), (2, -5)\}$                       4.  $\{(5, 2), (-2, 15), (-7, 15), (1, 5), (4, 15), (-7, 2)\}$

5.

<b>x</b>	4	-5	11	-5	23
<b>y</b>	-3	1	1	0	6

6.

<b>x</b>	7	14	11	-10	-1
<b>y</b>	-3	-9	-4	-3	15

7.

<b>x</b>	-3.0	3.5	4.1	-3.0	3.4
<b>y</b>	4.2	3.7	-3.8	3.7	4.0

8.

<b>x</b>	11	4	-2	4	-7
<b>y</b>	-7	-2	2	2	6

**EMPLOYMENT** For Exercises 9–12, use the table, which shows the percent of employed men and women in the U.S. labor force every five years from 1980 to 2000.

9. Is the relation (year, percent of men) a function? Explain.
10. Describe how the percent of employed men is related to the year.

Employed Members of Labor Force		
Year	Men (% of male population)	Women (% of female population)
1980	77.4	51.5
1985	76.3	54.5
1990	76.4	57.5
1995	75.0	58.9
2000	78.9	67.3

Source: U.S. Census Bureau

11. Is the relation (year, percent of women) a function? Explain.
12. Describe how the percent of employed women is related to the year.



# 7-2 Practice

## Representing Linear Functions

Find four solutions of each equation. Write the solutions as ordered pairs.

1.  $y = x - 5$

2.  $y = -7$

3.  $y = -3x + 1$

4.  $x - y = 6$

5.  $y = 2x + 4$

6.  $7x - y = 14$

Graph each equation by plotting ordered pairs.

7.  $y = 2x - 1$

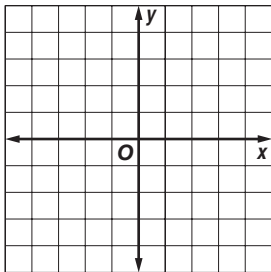

8.  $y = -6x + 2$

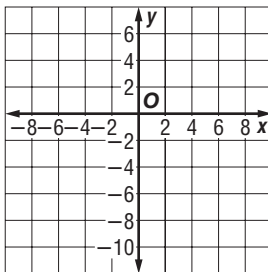

9.  $y = x + 4$

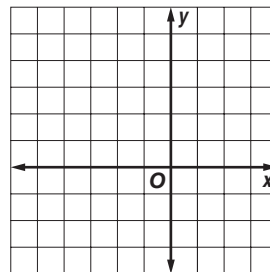

10.  $y = 7$

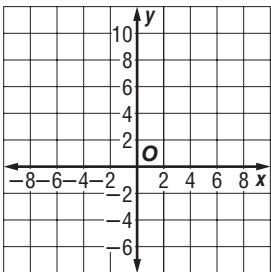

11.  $y = 3x - 9$

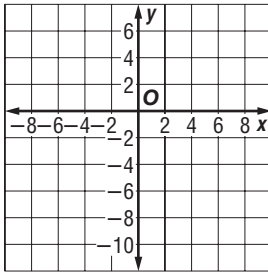

12.  $y = \frac{1}{2}x - 6$

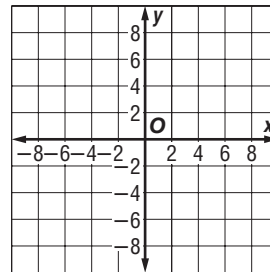

**COOKING** For Exercises 13–15, use the following information.

Kirsten is making gingerbread cookies using her grandmother’s recipe and needs to convert grams to ounces. The equation  $y = 0.04x$  describes the approximate number of ounces  $y$  in  $x$  grams.

13. Find three ordered pairs of values that satisfy this equation.

14. Draw the graph that contains these points.

15. Do negative values of  $x$  make sense in this case? Explain.

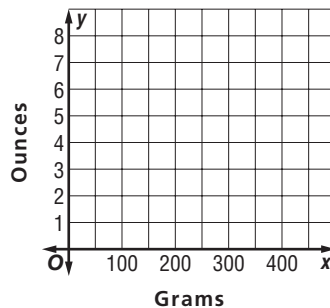

# 7-3

## Practice Rate of Change

Find the rate of change for each linear function.

1.

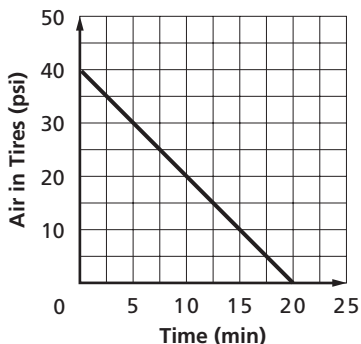

2.

Time (h)	Distance (km)
$x$	$y$
0	0
5	510
10	1020
15	1530

**TRADE** The graph shows the total U.S. exports from 1970 to 2000.

- Find the approximate rate of change between 1970 and 1975.
- Find the approximate rate of change between 1995 and 2000.
- Between which two years was the rate of change the least?

**U.S. Exports**

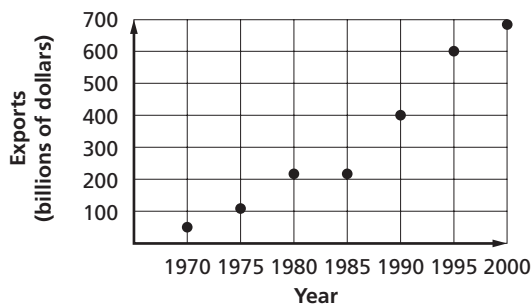

Source: *World Almanac*

**TRAFFIC MANAGEMENT** For Exercises 6 and 7, use the following information.

San Diego reserves express lanes on the freeways for the use of carpoolers. In order to increase traffic flow during rush hours, other drivers may use the express lanes for a fee. The toll increases with the number of cars on the road. The table shows a sample of possible tolls.

- Find the rate of change in the toll between 521 vehicles/h and 1122 vehicles/h.
- Find the rate of change in the toll between 2204 vehicles/h and 1551 vehicles/h.

Toll (\$)	Traffic Volume (vehicles/h)
1.00	521
2.00	1122
3.00	1551
4.00	2204

# 7-4

## Practice

### Constant Rate of Change and Direct Variation

Find the constant rate of change for each linear function and interpret its meaning.

1. **Fundraiser Profits**

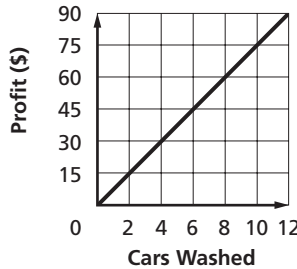

2.

Time (seconds)	Distance (yards)
$x$	$y$
1.2	6
2.4	8
3.6	10
4.8	12

Determine whether a proportional linear relationship exists between the two quantities shown in each of the functions indicated. Explain your reasoning.

5. Exercise 1

6. Exercise 2

**PAPER COSTS** The cost of paper varies directly with the number of reams bought. Suppose 2 reams cost \$5.10.

7. Write an equation that could be used to find the cost of  $x$  reams of paper.

8. Find the cost of 15 reams of paper.

**PHYSICAL SCIENCE** Recall that the length spring stretches varies directly with the amount of weight attached to it. A certain spring stretches 5 cm when a 10-gram weight is attached.

9. Write a direct variation equation relating the weight  $x$  and the amount of stretch  $y$ .

10. Estimate the stretch of the spring when it has a 42-gram weight attached.

# 7-5

## Practice

### Slope

Find the slope of each line.

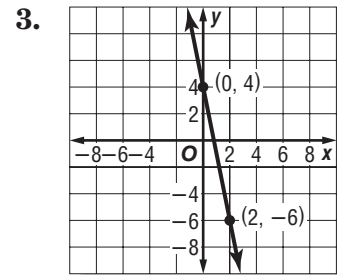
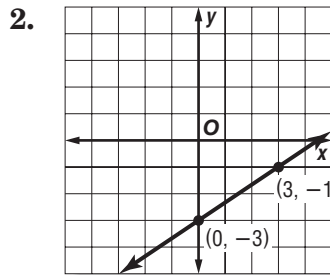
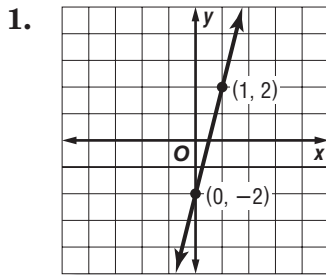

Find the slope of the line that passes through each pair of points.

4.  $A(-10, 6), B(-5, 8)$       5.  $C(7, -3), D(11, -4)$       6.  $E(5, 2), F(12, -3)$

7.  $G(-15, 7), H(-10, 6)$       8.  $J(13, 0), K(-3, -12)$       9.  $L(-5, 3), M(-4, 9)$

10.  $P(12, 2), Q(18, -2)$       11.  $R(-2, -3), S(-2, -5)$       12.  $T(-13, 8), U(21, 8)$

13. **CAKES** A wedding cake measures 2 feet high in the center and the diameter of the bottom tier is 12 inches. What is the slope of the cake?
14. **INSECTS** One particularly large ant hill found in 1997 measured 40 inches wide at the base and 18 inches high. What was the slope of the ant hill?
15. **ARCHAEOLOGY** Today, the Great Pyramid at Giza near Cairo, Egypt, stands 137 meters tall, coming to a point. Its base is a square with each side measuring 230 meters wide. What is the slope of the pyramid?
16. **BUSINESS** One warehouse uses 7-foot long ramps to load its forklifts onto the flat beds of trucks for hauling. If the bed of a truck is 2 feet above the ground and the ramp is secured to the truck at its end, what is the slope of the ramp while in operation? Round to the nearest hundredth.

# 7-6

## Practice

### Slope-Intercept Form

Given the slope and y-intercept, graph each line.

1. slope =  $\frac{3}{4}$ ,

y-intercept = -3

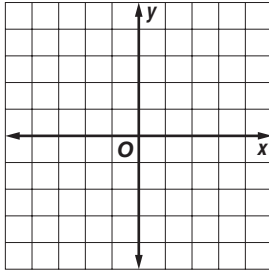

2. slope =  $\frac{5}{6}$ ,

y-intercept = 1

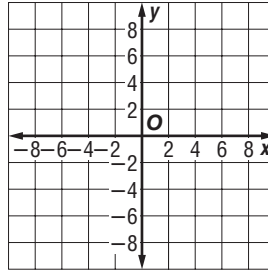

3. slope = 1,

y-intercept = 5

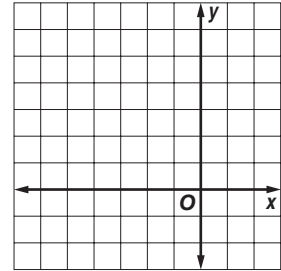

Graph each equation using the slope and y-intercept.

4.  $y = -\frac{1}{2}x - 4$

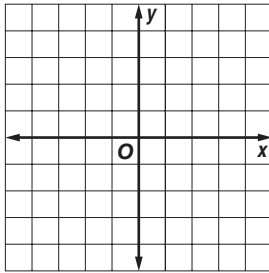

5.  $y = x - 4$

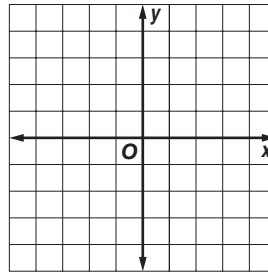

6.  $y = -6x + 3$

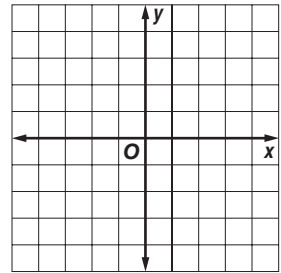

**EXERCISE** For Exercises 7 and 8, use the following information.

A person weighing 150 pounds burns about 320 Calories per hour walking at a moderate pace. Suppose that the same person burns an average of 1500 Calories per day through basic activities. The total Calories  $y$  burned by that person can be represented by the equation  $y = 320x + 1500$ , where  $x$  represents the number of hours spent walking.

7. Graph the equation using the slope and y-intercept.

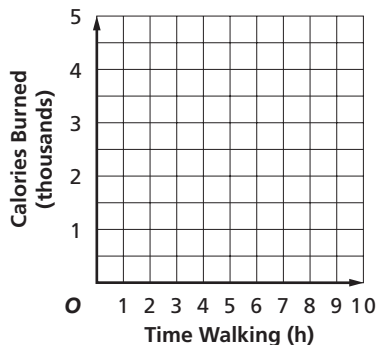

8. State the slope and y-intercept of the graph of the equation and describe what they represent.

# 7-7

## Practice

### Writing Linear Functions

Write an equation in slope-intercept form for each line.

1. slope = 3,  
y-intercept = -2

2. slope = 0,  
y-intercept = 7

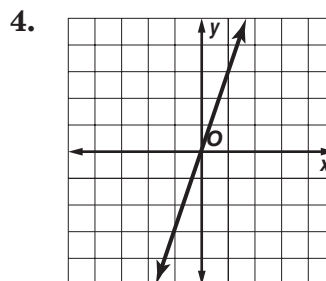
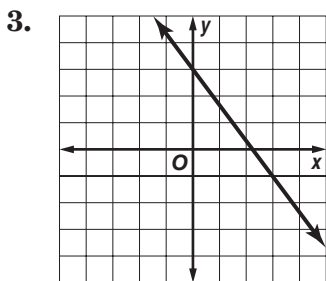

Write an equation in slope-intercept form for the line passing through each pair of points.

5. (9, 0) and (6, -1)      6. (8, 6) and (-8, 2)      7. (7, -5) and (-4, -5)
8. (2, 7) and (-1, 4)      9. (4, 4) and (-8, 10)      10. (0, 2) and (-3, 14)

**BUSINESS** For Exercises 11 and 12, use the following information.

Flourishing Flowers charges \$125 plus \$60 for each standard floral arrangement to deliver and set up flowers for a banquet.

11. Write an equation in slope-intercept form that shows the cost  $y$  for flowers for  $x$  number of arrangements.
12. Find the cost of providing 20 floral arrangements.

**INSULATION** For Exercises 13 and 14, use the following information.

Renata González wants to increase the energy efficiency of her house by adding to the insulation previously installed. The better a material protects against heat loss, the higher its R-value, or resistance to heat flow. The table shows the R-value of fiberglass blanket insulation per inch of thickness. The existing insulation in Renata's attic has an R-value of 10.

R-value	Thickness (in.)
0.0	0
3.2	1
6.4	2
9.6	3

Source: Oak Ridge National Laboratory

13. Write an equation in slope-intercept form that shows the total R-value  $y$  in the attic if she adds  $x$  number of inches of additional insulation.
14. Estimate the total R-value in the attic if she adds 6 inches of insulation.

# 7-8

## Practice

### Prediction Equations

**BEVERAGES** For Exercises 1 and 2, use the table that shows the amount of whole milk consumed per person in the United States.

Year	Gallons per Person
1990	10.2
1995	8.3
2000	7.7
2001	7.4
2002	7.3

Source: U.S. Census Bureau

1. Make a scatter plot and draw a best-fit line.

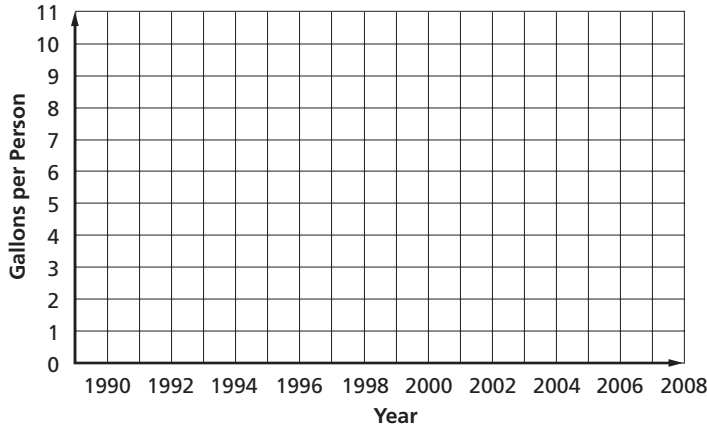

2. Use the best-fit line to predict the amount of whole milk consumed per person in 2008.

**EDUCATION** For Exercises 3 and 4, use the table that shows the number of students graduating from medical school in the United States from 1980 to 2000.

Year	Graduates
1980	15,113
1985	16,318
1990	15,398
1995	15,888
2000	16,112

Source: U.S. Census Bureau

3. Make a scatter plot and draw a best-fit line.

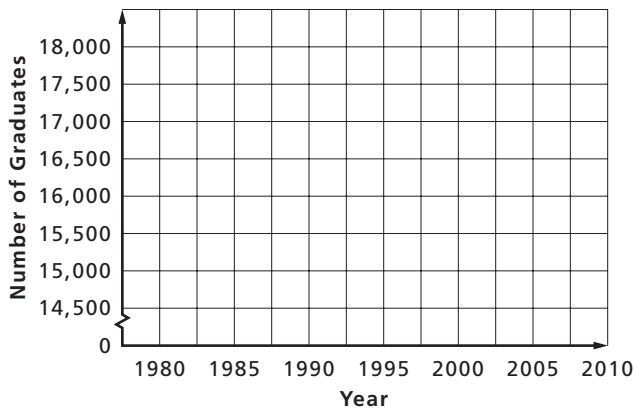

Source: U.S. Census Bureau

4. Write an equation for the best-fit line and use it to predict the number of medical school graduates in 2010.

**8-1 Practice*****Solving Equations with Variables on Each Side***

Solve each equation. Check your solution.

1.  $3g - 12 = 9g$

2.  $14m = 18 + 12m$

3.  $7c - 7 = 4c + 17$

4.  $-11t = 15 - 6t$

5.  $20s + 4 = 13s - 10$

6.  $-2h - 16 = 3h - 6$

7.  $27j - 6 = 14j + 7$

8.  $-1 + 19w = 11w + 23$

9.  $8 - p = -12 - 3p$

10.  $9k - 26 = 6k - 8$

11.  $28 - 4d = 5d - 17$

12.  $2y + 7 = y$

13.  $11.7 - 2x = x$

14.  $3b + 4.4 = 2.6 - 6b$

15.  $\frac{3}{4}y - 6 = \frac{1}{4}y + 10$

16.  $2c + 7.5 = 6.2 - 3c$

17.  $5d - 11 = 2d + 2$

18.  $6a - 10 = 2a - 7$

19.  $8n - 6 = -9n + 11$

20.  $2f - 9 = 14f + 1$

Define a variable and write an equation to find each number. Then solve.

21. Twice a number is 60 more than five times the number. What is the number?

22. Four times a number is 21 more than the number. What is the number?

23. Eight less than three times a number equals the number. What is the number?

24. A number equals six less than four times a number. What is the number?

25. **TENNIS** The area of a tennis court is  $2808 \text{ ft}^2$ , or 8 square feet more than 3.5 times the size of the area of a racquetball court. What is the area of a racquetball court?

26. **CELLULAR PHONES** One cellular phone carrier charges \$26.50 a month plus \$0.15 a minute for local calls. Another carrier charges \$14.50 a month and \$0.25 a minute for local calls. For how many minutes is the cost of the plans the same?



**8-2 Practice****Solving Equations with Grouping Symbols**

Solve each equation. Check your solution.

1.  $4(j - 7) = 12$

2.  $5(2k + 10) = 40$

3.  $7(2p + 3) - 8 = 6p + 29$

4.  $7(g - 4) = 3$

5.  $3(4c + 5) = 24$

6.  $2(a - 1) = 3(a + 1)$

7.  $3(x - 3) = 5(1.5 + x)$

8.  $2(1.5m + 3) = 3.5m - 1$

9.  $a - \frac{5}{10} = 2a - \frac{3}{5}$

10.  $2.2x - 5 = 2(1.4x + 3)$

11.  $\frac{d}{0.2} = 3d + 2.1$

12.  $5n + 3 = 2(n + 2) - 3n$

13.  $\frac{2}{3}a + 2 = \frac{1}{3}(4a + 1)$

14.  $y - 7 = \frac{1}{4}(y + 2)$

15.  $5(f + 2) = 9 + 5f$

Find the dimensions of each rectangle. The perimeter is given.

16.  $P = 122$  m

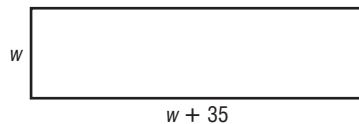

17.  $P = 244$  yd

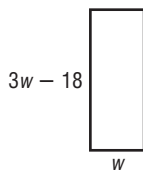

18.  $P = 698$  cm

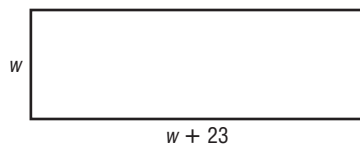

19.  $P = 86$  in.

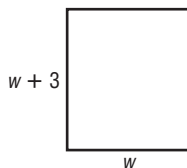

20. **GEOMETRY** The perimeter of a rectangle is 80 feet. Find the dimensions if the length is 5 feet longer than four times the width. Then find the area of the rectangle.

21. **NUMBER THEORY** Five times the sum of three consecutive integers is 150. What are the integers?

# 8-3 Practice

## Inequalities

Write an inequality for each sentence.

- More than 3400 people attended the flea market.
- Her earnings at \$11 per hour were no more than \$121.
- The 10-km race time of 84 minutes was at least twice as long as the winner's time.
- A savings account increased by \$70 is now more than \$400.

For the given value, state whether each inequality is true or false.

- |                                 |                                          |
|---------------------------------|------------------------------------------|
| 5. $9 - x > 3, x = 6.5$         | 6. $9.5 + n < 19, n = 10$                |
| 7. $3k < 27 \frac{1}{2}, k = 8$ | 8. $21 \leq 4c, c = 5.2$                 |
| 9. $\frac{x}{4} \leq 8, x = 32$ | 10. $\frac{9}{c} > 2, c = 3 \frac{1}{2}$ |

Graph each inequality on a number line.

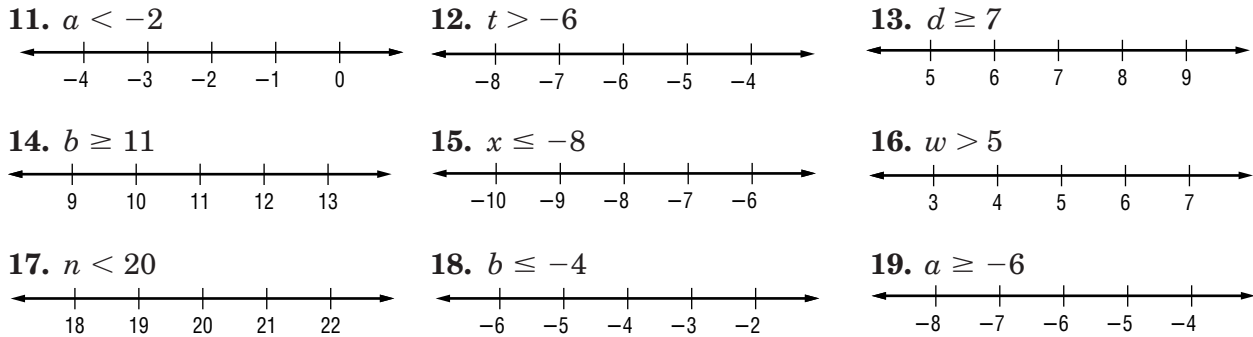

Write the inequality for each graph.



**8-4 Practice****Solving Inequalities by Adding or Subtracting**

Solve each inequality. Check your solution.

1.  $h + 1 < 7$

2.  $c + 3 > -4$

3.  $22 \leq m - 9$

4.  $-6 \geq g + 4$

5.  $15 + d > 10$

6.  $p + (-8) \leq -12$

7.  $-13 < k - (-16)$

8.  $-1 + s \leq 5$

9.  $12 > w - (-0.3)$

10.  $-1\frac{7}{8} < d + (-2)$

11.  $z - 0.9 > -4.8$

12.  $b - \frac{1}{5} < 3\frac{1}{10}$

Solve each inequality. Then graph the solution on a number line.

13.  $5 + a > 16$

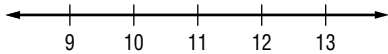

14.  $c + 12 \leq 14$

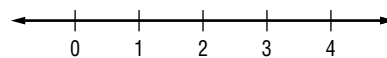

15.  $-20 > h - 3$

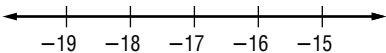

16.  $16 \geq k + (-17)$

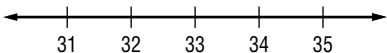

17.  $p - (-2) \geq -4\frac{1}{2}$

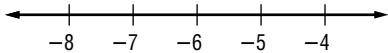

18.  $-2 + z < 3\frac{3}{4}$

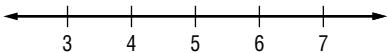

**19. TRANSPORTATION** A certain minivan has a maximum carrying capacity of 1200 pounds. If the luggage weighs 150 pounds, what is the maximum weight allowable for passengers?

**20. DRINKS** A large punch bowl holds 12 gallons of liquids. If five gallons of ginger ale have already been poured into the bowl, what is the most fruit juice that can be added?

**21. FUND-RAISING** A neighborhood association wants to replace the playground equipment at a park. The playground equipment they would like to buy starts at \$4500. If they have already raised \$2700, what is the least they must still collect?

**8-5**

**Practice**

***Solving Inequalities by Multiplying or Dividing***

Solve each inequality and check your solution. Then graph the solution on a number line.

1.  $9x > 18$

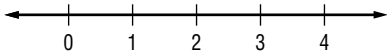

2.  $10d \leq 80$

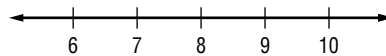

3.  $25 \leq 5c$

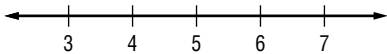

4.  $\frac{t}{13} > 3$

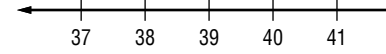

5.  $24 \geq \frac{g}{-4}$

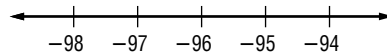

6.  $-78 > 6h$

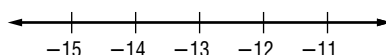

7.  $\frac{f}{-5} < -12$

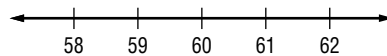

8.  $100 \geq -4s$

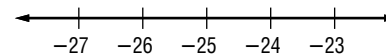

9.  $\frac{p}{-36} < 6$

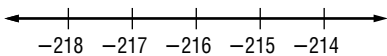

10.  $-4 > \frac{c}{-3.5}$

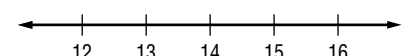

11.  $-24 < \frac{1}{2}b$

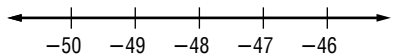

12.  $-3 \leq \frac{c}{-1.5}$

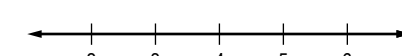

**13. DISCOUNTS** To qualify for a store discount, Jorge's soccer team must spend at least \$560 for new jerseys. The team needs 20 jerseys.

- a. Write an inequality to represent how much the team should spend on each jersey to qualify for the discount.
- b. How much should the team spend for each jersey?

**14. POLITICS** Mi-Ling wants to mail at least 850 fliers encouraging voters to vote for the upcoming school levy. She has five days to get them all in the mail.

- a. Write an inequality to represent how many fliers Mi-Ling must mail every day.
- b. How many fliers should Mi-Ling mail each day?

**8-6 Practice****Solving Multi-Step Inequalities**

Solve each inequality and check your solution. Then, graph the solution on a number line.

1.  $2x + 12 < -12$

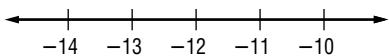

2.  $6 + 2p \leq 16$

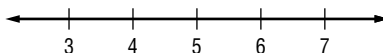

3.  $5 - 4k \leq 21$

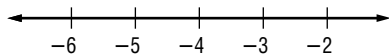

4.  $3(d + 2) > 6$

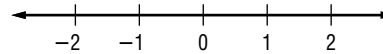

5.  $\frac{m}{2} - 7 > 4$

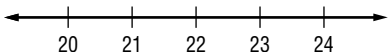

6.  $0.5c - 2 \leq 4.5$

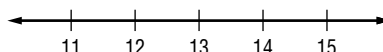

7.  $\frac{2}{3}(12 - x) > 4$

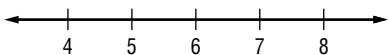

8.  $\frac{1}{2}(8 - c) < 7.5$

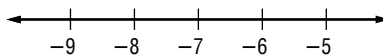

9.  $\frac{c}{3} + 7 > 5\frac{1}{2}$

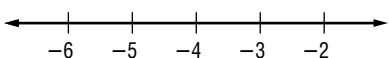

10.  $7 + 2p < -14$

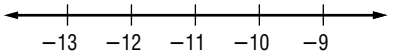

11.  $-3(x + 3) > 7.5$

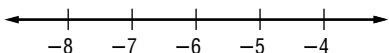

12.  $5 - 3c \leq c + 17$

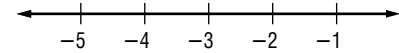

13.  $2(n - 5) \leq -7$

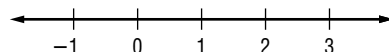

14.  $\frac{18 - n}{2} \leq 6$

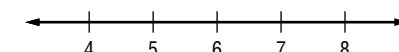

15. Two times a number less 10 is greater than five times the same number plus 2. For what number or numbers is this true?

16. One-half of the sum of a number and 12 is less than 27. What is the number?

17. **STATE FAIR** Admission to the state fair costs \$5 and each ride costs \$0.75. If Ahmed wants to spend no more than \$14 at the fair, how many rides can he ride?

18. **GIFTS** Yuko wants to buy teddy bears that cost \$8.50 each for her eight nieces and nephews. She would like to get a hat for each teddy bear, also. If Yuko wants to spend no more than \$94, how much can she spend on each hat?

**9-1 Practice****Squares and Square Roots**

Find each square root, if possible.

- |                  |                  |                   |
|------------------|------------------|-------------------|
| 1. $\sqrt{100}$  | 2. $\sqrt{144}$  | 3. $\sqrt{-36}$   |
| 4. $\sqrt{121}$  | 5. $\sqrt{-148}$ | 6. $-\sqrt{4}$    |
| 7. $-\sqrt{9}$   | 8. $-\sqrt{49}$  | 9. $\sqrt{256}$   |
| 10. $\sqrt{529}$ | 11. $\sqrt{361}$ | 12. $-\sqrt{196}$ |

Use a calculator to find each square root to the nearest tenth.

- |                     |                     |                     |
|---------------------|---------------------|---------------------|
| 13. $-\sqrt{2.25}$  | 14. $\sqrt{38}$     | 15. $\sqrt{249}$    |
| 16. $\sqrt{131}$    | 17. $\sqrt{7}$      | 18. $\sqrt{52}$     |
| 19. $\sqrt{168}$    | 20. $\sqrt{499}$    | 21. $-\sqrt{217}$   |
| 22. $\pm\sqrt{218}$ | 23. $\pm\sqrt{42}$  | 24. $\pm\sqrt{94}$  |
| 25. $\pm\sqrt{50}$  | 26. $\pm\sqrt{137}$ | 27. $\pm\sqrt{208}$ |

28. Find the negative square root of 840 to the nearest tenth.
29. If  $x^2 = 476$ , what is the value of  $x$  to the nearest tenth?
30. The number  $\sqrt{22}$  lies between which two consecutive whole numbers?  
Do not use a calculator.

Estimate each square root to the nearest whole number. Do not use a calculator.

- |                 |                  |                  |
|-----------------|------------------|------------------|
| 31. $\sqrt{76}$ | 32. $\sqrt{123}$ | 33. $\sqrt{300}$ |
| 34. $\sqrt{90}$ | 35. $\sqrt{19}$  | 36. $\sqrt{248}$ |

37. **GEOMETRY** A square tarpaulin covering a softball field has an area of  $441 \text{ m}^2$ .  
What is the length of one side of the tarpaulin?
38. **MONUMENTS** Refer to Example 4 on page 466 of your textbook. The highest observation deck on the Eiffel Tower in Paris is about 899 feet above the ground.  
About how far could a visitor see on a clear day?

**9-2 Practice*****The Real Number System***

Name all of the sets of numbers to which each real number belongs. Let **N** = natural numbers, **W** = whole numbers, **Z** = integers, **Q** = rational numbers, and **I** = irrational numbers.

- |                  |                   |                    |
|------------------|-------------------|--------------------|
| 1. 15            | 2. -41            | 3. $\frac{1}{4}$   |
| 4. $\frac{1}{3}$ | 5. 0.212121...    | 6. $\sqrt{8}$      |
| 7. $\sqrt{45}$   | 8. $\frac{36}{9}$ | 9. $-\frac{28}{7}$ |
| 10. 2.31         | 11. 45.6          | 12. 0.090090009... |

Determine whether each statement is *sometimes*, *always*, or *never* true.

13. A decimal number is an irrational number.
14. An integer is a whole number.
15. A natural number is an integer.
16. A negative integer is a natural number.

Replace each  $\bullet$  with  $<$ ,  $>$ , or  $=$  to make a true statement.

- |                                          |                                     |
|------------------------------------------|-------------------------------------|
| 17. $3.2 \bullet \sqrt{9.5}$             | 18. $1\frac{1}{2} \bullet \sqrt{3}$ |
| 19. $\sqrt{17} \bullet 4.1$              | 20. $\sqrt{7.84} \bullet 2.8$       |
| 21. $1\frac{3}{4} \bullet \sqrt{3.0625}$ | 22. $3.67 \bullet \sqrt{12}$        |

Order each set of numbers from least to greatest.

23.  $\sqrt{49}$ ,  $6.\overline{91}$ ,  $7\frac{1}{8}$ ,  $\frac{15}{2}$
24.  $4\frac{1}{3}$ ,  $\sqrt{43}$ ,  $\frac{12}{3}$ , 4.13
25. -2, -1.5,  $-1\frac{8}{10}$ ,  $-\sqrt{6}$

**ALGEBRA** Solve each equation. Round to the nearest tenth, if necessary.

- |                 |                   |                    |
|-----------------|-------------------|--------------------|
| 26. $h^2 = 361$ | 27. $k^2 = 10.24$ | 28. $c^2 = 111$    |
| 29. $330 = t^2$ | 30. $0.089 = u^2$ | 31. $w^2 = 0.0144$ |
32. **GARDENING** Ray planted a square garden that covers an area of 200 ft<sup>2</sup>. How many feet of fencing does he need to surround the garden?

**9-3**

**Practice  
Triangles**

Classify each angle as *acute*, *obtuse*, *right*, or *straight*.

- 1.  $\angle MTN$
- 2.  $\angle MTO$
- 3.  $\angle MTP$
- 4.  $\angle MTQ$
- 5.  $\angle MTR$
- 6.  $\angle NTO$

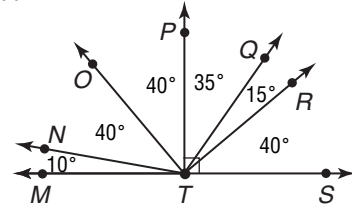

Find the value of  $x$  in each triangle. Then classify each triangle as *acute*, *right*, or *obtuse*.

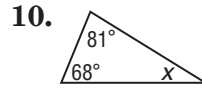
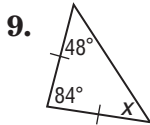
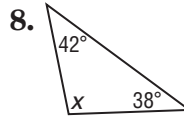
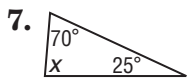

- 11. **ALGEBRA** The measures of the angles of a triangle are in the ratio 5:6:9. What is the measure of each angle?
- 12. **ALGEBRA** Determine the measures of the angles of  $\triangle MNO$  if the measures of the angles are in the ratio 2:4:6.

Classify each triangle by its angles and by its sides.

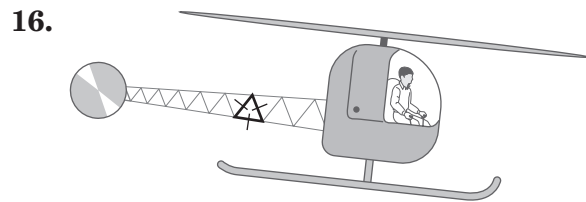
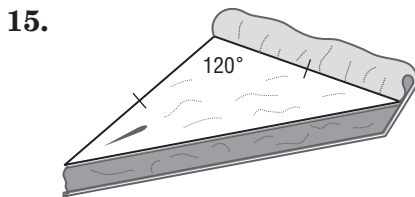
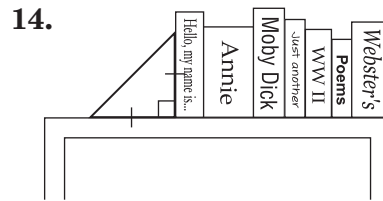
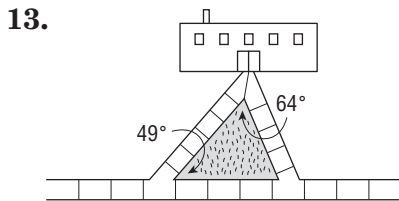



**9-4**

**Practice**

*The Pythagorean Theorem*

Find the length of the hypotenuse in each right triangle. Round to the nearest tenth, if necessary.

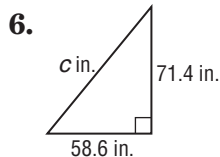
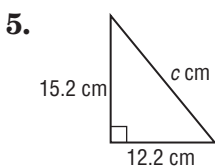
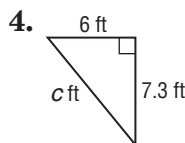
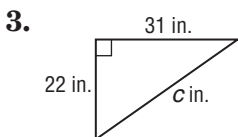
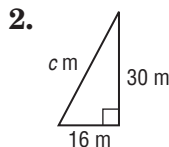
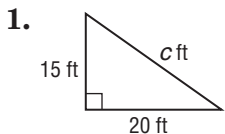

If  $c$  is the measure of the hypotenuse, find each missing measure. Round to the nearest tenth, if necessary.

- 7.  $a = ?$ ,  $b = 15$ ,  $c = 31$
- 8.  $a = 8$ ,  $b = ?$ ,  $c = 16$
- 9.  $a = 11$ ,  $b = 16$ ,  $c = ?$
- 10.  $a = ?$ ,  $b = 13$ ,  $c = 19$
- 11.  $a = 10$ ,  $b = ?$ ,  $c = 18$
- 12.  $a = 21$ ,  $b = 23$ ,  $c = ?$
- 13.  $a = ?$ ,  $b = 27$ ,  $c = 35$
- 14.  $a = 48$ ,  $b = ?$ ,  $c = 61$
- 15.  $a = 26$ ,  $b = \sqrt{596}$ ,  $c = ?$
- 16.  $a = ?$ ,  $b = 12$ ,  $c = \sqrt{318}$

The lengths of three sides of a triangle are given. Determine whether each triangle is a right triangle.

- 17. 5 m, 5 m, 10 m
- 18. 9 in., 12 in., 15 in.
- 19. **ARCHITECTURE** The diagonal distance covered by a flight of stairs is 21 ft. If the stairs cover 10 ft horizontally, how tall are they?
- 20. **KITES** A kite is flying at the end of a 300-foot string. It is 120 feet above the ground. About how far away horizontally is the person holding the string from the kite?

# 9-5

## Practice

### The Distance Formula

Find the distance between each pair of points. Round to the nearest tenth, if necessary.

1.  $A(5, 2), B(3, 4)$
2.  $C(-2, -4), D(1, 3)$
3.  $E(-3, 4), F(-2, 1)$
4.  $G(0, 0), H(-7, 8)$
5.  $R(-4, -8), S(2, -3)$
6.  $G(9, 9), H(-9, -9)$
7.  $M(1, 1), N(-10, -10)$
8.  $P\left(1\frac{1}{2}, 3\right), Q\left(5, 6\frac{1}{4}\right)$
9.  $R\left(7, 4\frac{1}{2}\right), S\left(6\frac{1}{2}, 3\frac{1}{4}\right)$
10.  $T\left(-3\frac{1}{2}, -4\frac{1}{4}\right), U\left(5\frac{1}{2}, 1\frac{1}{2}\right)$
11.  $A(5, 1), B(-4, -3)$
12.  $V(4, 6), W(-8, -12)$
13.  $C(-2, -4), D(-5, 6)$
14.  $X(1, -7), Y(-1, 7)$
15.  $E(5, -3), F(-7, 8)$
16.  $A(8, 8), B(-8, -8)$

**GEOMETRY** Find the perimeter of each figure.

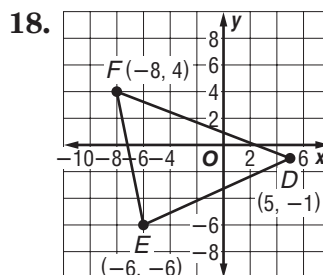
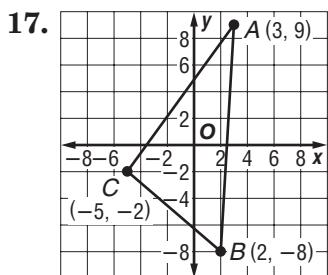

19. **MAPS** On a map of the school, the baseball field is located at the coordinates (1, 7). The front entrance of the school is located at (5, 2). If each coordinate unit corresponds to 10 yards, how far is it from the front entrance to the baseball field?
20. Determine whether  $\triangle XYZ$  with vertices  $X(3, 4)$ ,  $Y(2, -3)$ , and  $Z(-5, -2)$  is isosceles. Explain your answer.
21. Is  $\triangle DEF$  with vertices  $D(1, 4)$ ,  $E(6, 2)$ ,  $F(-1, 3)$  a scalene triangle? Explain.

# 9-6

## Practice

### Similar Polygons and Indirect Measurement

In Exercises 1-8, the triangles are similar. Find each value of  $x$ .

1.

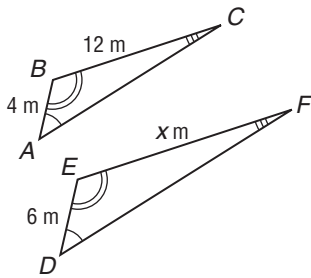

2.

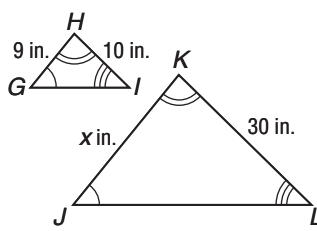

3.

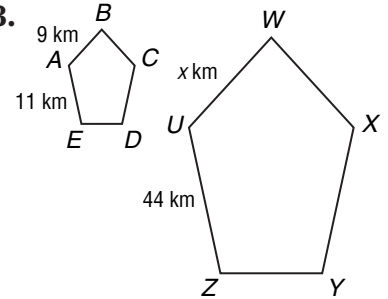

4.

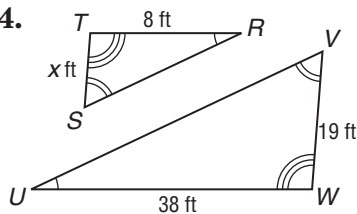

5.

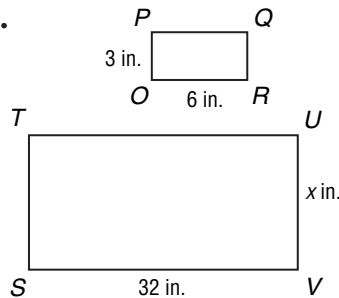

6.

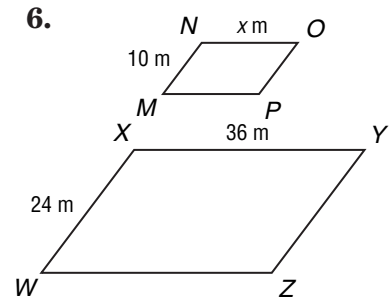

7.

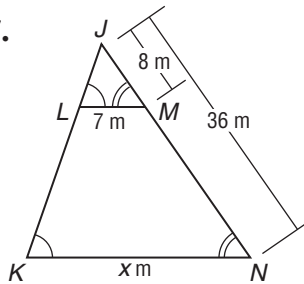

8.

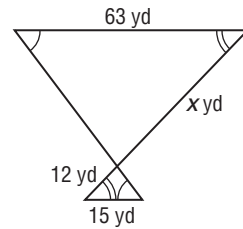

For Exercises 9-12, write a proportion. Then determine the missing measure.

9. **CHIMNEYS** A 6-ft observer casts a 4-ft shadow at the same time a chimney casts a 238-foot shadow. How tall is the chimney?

10. **BUILDINGS** The May Road Apartments in Hong Kong cast a 90-meter shadow at the same time a 1.5-meter tall tenant casts a 0.75-meter shadow. How tall is the apartment building?

11. **WORLD RECORDS** The world's tallest man lived from 1918 to 1940. He cast a 4-foot  $5\frac{1}{2}$  inch shadow when a 6-foot pole cast a 3-foot shadow. How tall was he?

12. **SHADOWS** A man casts a 14-foot shadow. A 4-foot child casts a 9-foot 4-inch shadow at the same time. How tall is the man?

# 10-1 Practice

## Line and Angle Relationships

In the figure at the right,  $m \parallel n$  and  $r$  is a transversal. If  $m\angle 2 = 45^\circ$ , find the measure of each angle.

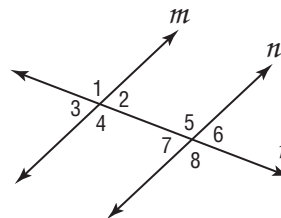

- |               |               |
|---------------|---------------|
| 1. $\angle 4$ | 2. $\angle 5$ |
| 3. $\angle 7$ | 4. $\angle 8$ |
| 5. $\angle 6$ | 6. $\angle 3$ |

In the figure at the right,  $d \parallel e$  and  $a$  is a transversal. If  $m\angle 5 = 143^\circ$ , find the measure of each angle.

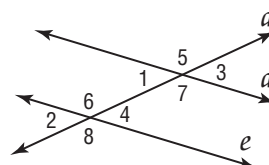

- |                |                |
|----------------|----------------|
| 7. $\angle 7$  | 8. $\angle 6$  |
| 9. $\angle 4$  | 10. $\angle 2$ |
| 11. $\angle 1$ | 12. $\angle 8$ |

Find the value of  $x$  in each figure.

13.

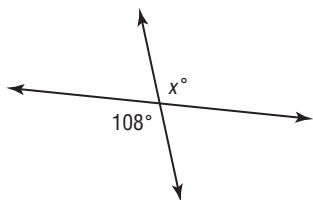

14.

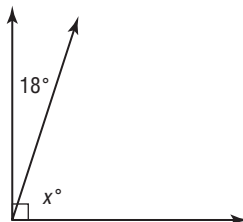

15.



16.

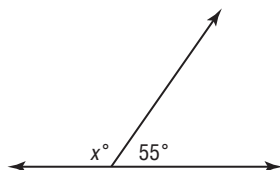

17.

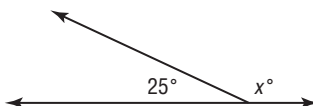

18.

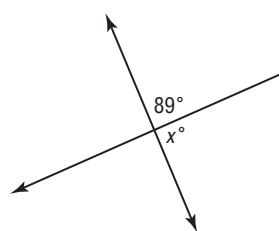

19. Angles  $Q$  and  $R$  are complementary. Find  $m\angle R$  if  $m\angle Q = 24^\circ$ .
20. Find  $m\angle J$  if  $m\angle K = 29^\circ$  and  $\angle J$  and  $\angle K$  are supplementary.
21. The measures of angles  $A$  and  $B$  are equal and complementary. What is the measure of each angle?
22. **ALGEBRA** Angles  $G$  and  $H$  are complementary. If  $m\angle G = 3x + 6$  and  $m\angle H = 2x - 11$ , what is the measure of each angle?

# 10-2 Practice

## Congruent Triangles

Complete the congruence statement if  $\triangle CMH \cong \triangle PLF$  and  $\triangle DNO \cong \triangle AET$ .

1.  $\angle M \cong$  ?      2.  $\overline{MC} \cong$  ?      3.  $\overline{DN} \cong$  ?      4.  $\angle A \cong$  ?  
 5.  $\overline{FL} \cong$  ?      6.  $\angle C \cong$  ?      7.  $\overline{TE} \cong$  ?      8.  $\angle O \cong$  ?

Find the value of  $x$  for each pair of congruent triangles.

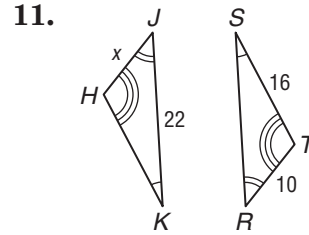
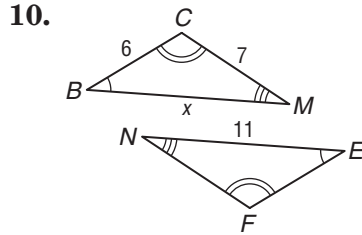
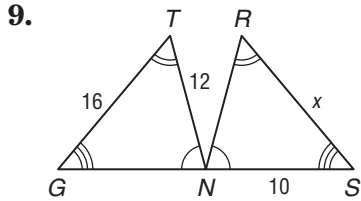

12. ALGEBRA If  $\triangle DEC \cong \triangle PRM$ , what is the value of  $x$ ?

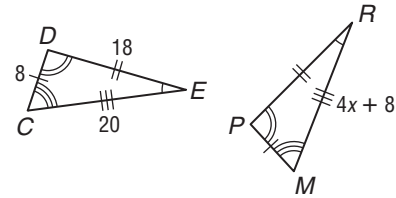

13. ALGEBRA If  $\triangle AHB \cong \triangle KJP$ , what is the value of  $x$ ?

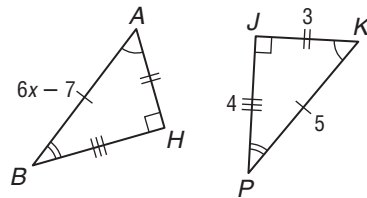

**KALEIDOSCOPE** For Exercises 14–19, use the kaleidoscope pattern at the right. Name a triangle that appears to be congruent to each triangle listed.

14.  $\triangle GEH$       15.  $\triangle FCH$   
 16.  $\triangle DEC$       17.  $\triangle ABD$   
 18.  $\triangle HEF$       19.  $\triangle CBE$

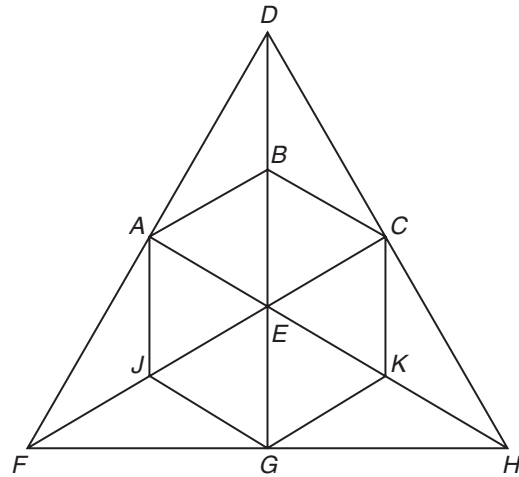

# 10-3 Practice

## Transformations on the Coordinate Plane

Find the coordinates of the vertices of each figure after a reflection over the given axis. Then graph the reflection image.

1.  $y$ -axis

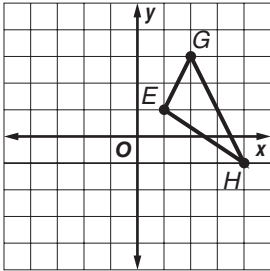

2.  $x$ -axis

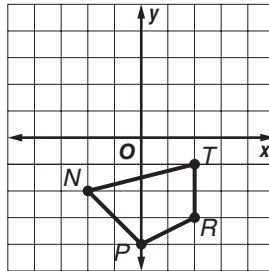

3.  $x$ -axis

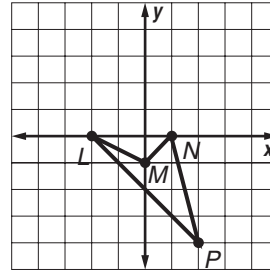

For Exercises 4–6, use the graph shown.

4. Graph the image of the figure after a dilation centered at the origin with a scale factor of 2.
5. Graph the image of the figure after a dilation centered at the origin with a scale factor of 1.5.
6. Find the coordinates of the vertices of the figure after a dilation centered at the origin with a scale factor of  $\frac{1}{2}$ .

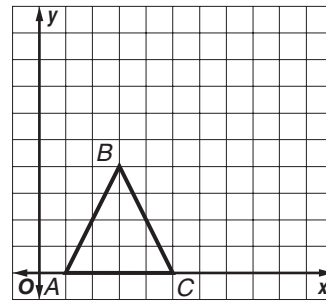

For Exercises 7–9, use the graph shown.

7. Graph the image of the figure after a dilation centered at the origin with a scale factor of  $\frac{1}{3}$ .
8. Find the coordinates of the vertices of the figure after a dilation centered at the origin with a scale factor of 4.
9. Graph the image of the figure after a dilation centered at the origin with a scale factor of  $\frac{4}{3}$ .

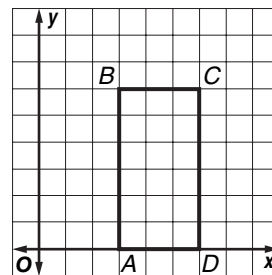

# 10-4 Practice

## Quadrilaterals

**ALGEBRA** Find the value of  $x$ . Then find the missing angle measures.

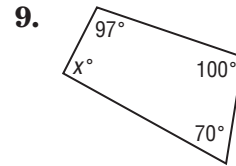
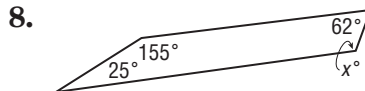
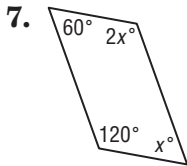
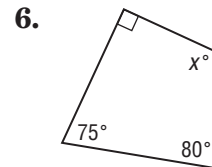
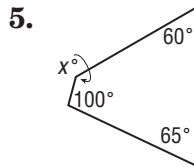
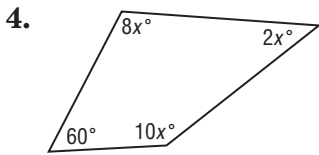
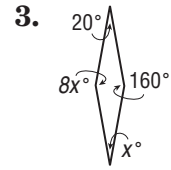
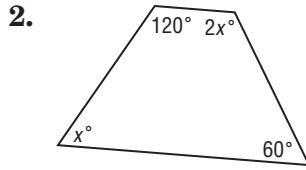
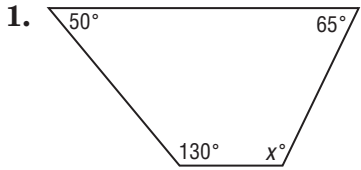

Tell whether each statement is *sometimes*, *always*, or *never* true.

10. A parallelogram is a trapezoid.
11. A square is a quadrilateral.
12. A rhombus is a rectangle.
13. A quadrilateral is a rectangle.

Make a drawing of each quadrilateral. Then classify each quadrilateral using the name that *best* describes it.

14. In quadrilateral  $ACFG$ ,  $m\angle A = 60^\circ$ ,  $m\angle C = 120^\circ$ ,  $m\angle F = 115^\circ$ , and  $m\angle G = 65^\circ$ .
  
15. In quadrilateral  $EMNP$ ,  $m\angle E = 90^\circ$ ,  $m\angle M = 80^\circ$ ,  $m\angle N = 60^\circ$ , and  $m\angle P = 130^\circ$ .

# 10-5 Practice

## Polygons

Find the sum of the measures of the interior angles of each polygon.

- |                  |             |            |
|------------------|-------------|------------|
| 1. quadrilateral | 2. decagon  | 3. 12-gon  |
| 4. heptagon      | 5. pentagon | 6. hexagon |
| 7. 25-gon        | 8. 100-gon  |            |

Find the measure of an interior angle of each polygon.

- |                    |                           |                     |
|--------------------|---------------------------|---------------------|
| 9. regular nonagon | 10. regular octagon       | 11. regular hexagon |
| 12. regular 12-gon | 13. regular quadrilateral | 14. regular decagon |

**TESSELLATIONS** For Exercises 15 and 16, identify the polygons used to create each tessellation.

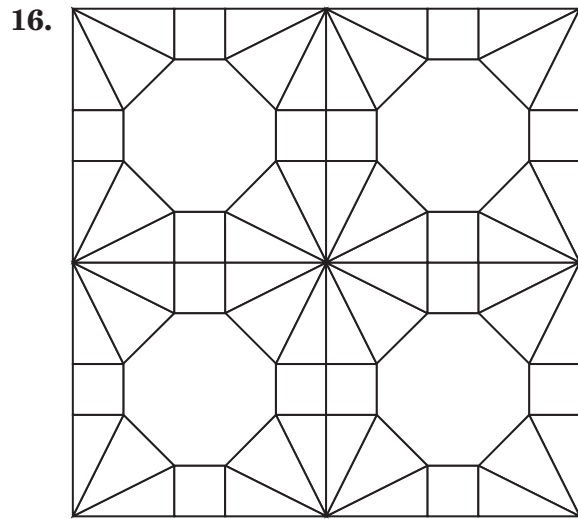
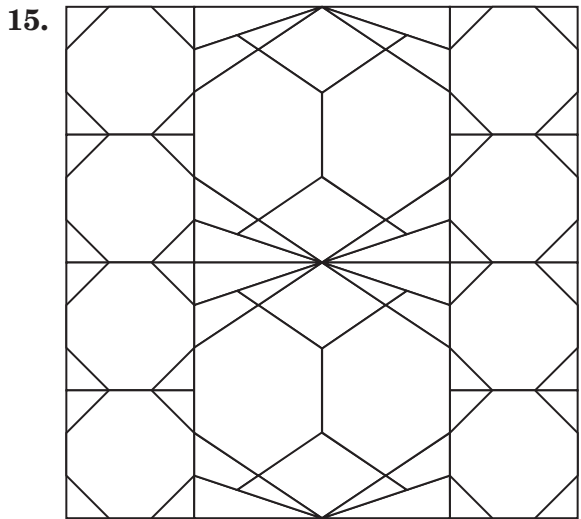

17. Which figure best represents a regular polygon?

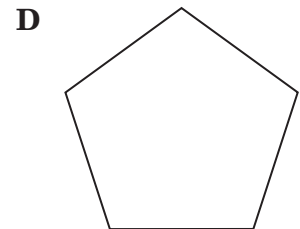
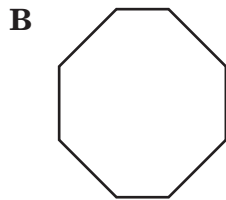
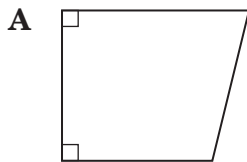



# 10-6 Practice

## Area: Parallelograms, Triangles, and Trapezoids

Find the area of each figure described.

1. parallelogram: base, 12 m; height, 10 m
2. trapezoid: height, 13 cm; bases, 3 cm, 7 cm
3. triangle: base, 9.4 ft; height, 5 ft
4. triangle: base, 8.5 km; height, 14 km
5. parallelogram: base, 15 yd; height, 7 yd
6. trapezoid: height, 7 m; bases, 6 m, 9 m

Find the area of each figure.

7.

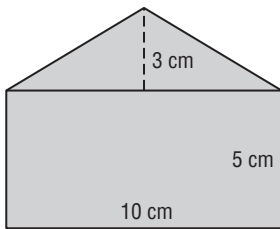

8.

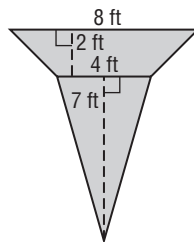

9.

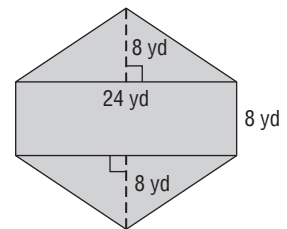

**GEOGRAPHY** For Exercises 10–12, use the approximate measurements to estimate the area of each state.

10. Maine

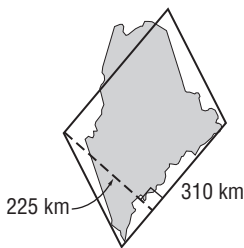

11. Idaho

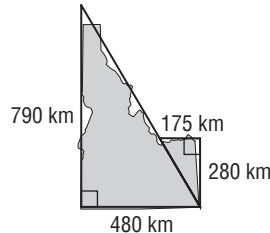

12. North Carolina

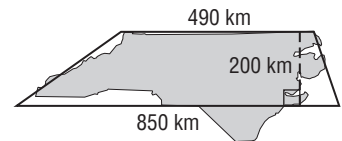

13. Suppose a triangle has an area of 220 square meters. What is the measure of the height if the base measures 20 meters?
14. A trapezoid has an area of 27.5 square centimeters. What is the measure of the height if the bases measure 7 centimeters and 4 centimeters?
15. Find the base of a parallelogram with a height of 10.5 feet and an area of 189 square feet.

**10-7 Practice*****Circumference and Area: Circles***

Find the circumference and area of each circle. Round to the nearest tenth.

1. The diameter is 18 yards.
2. The radius is 4 meters.
3. The diameter is 4.2 meters.
4. The radius is 4.5 feet.
5. The radius is  $9\frac{3}{4}$  miles.
6. The diameter is 6 kilometers.

Match each circle described in the column on the left with its corresponding measurement in the column on the right.

- |                        |                                  |
|------------------------|----------------------------------|
| 7. radius: 8.5 units   | a. circumference: 53.4 units     |
| 8. diameter: 9 units   | b. area: 33.2 units <sup>2</sup> |
| 9. diameter: 6.5 units | c. area: 63.6 units <sup>2</sup> |
| 10. radius: 12 units   | d. circumference: 75.4 units     |
11. **SPORTS** A baseball has a radius of about 1.5 inches. Home plate is 16 inches wide. If a baseball were rolled across home plate, how many complete rotations would it take to cover the distance?
  12. **SPORTS** A soccer ball has a circumference of about 28 inches, while the goal is 24 feet wide. How many soccer balls would be needed to cover the distance between the goalposts?
  13. **HISTORY** Chariot races reached their peak in popularity in ancient Rome around the 1st and 2nd centuries A.D. A chariot wheel had a radius of about one foot. One lap around the track in the Circus Maximus was approximately 2,300 feet. How many chariot-wheel revolutions did it take to complete one lap?
  14. **CULTURE** One of the artistic traditions of Tantric Buddhism is *dul-tson-kyil-khor*, which is the creation of intricately designed prayer circles (called mandalas) using colored sand. The sand is funneled through a hollow metal tube about 0.5 centimeter in diameter. If the prayer circle were a meter across, approximately how many funnel-tips of sand would be needed to cover its surface?

# 10-8 Practice

## Area: Composite Figures

Find the area of each figure to the nearest tenth, if necessary.

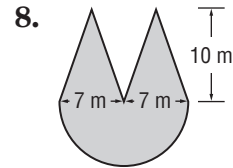
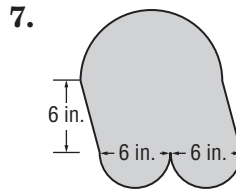
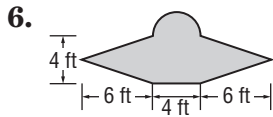
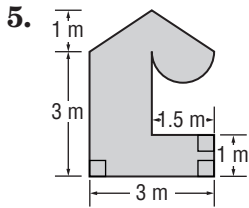
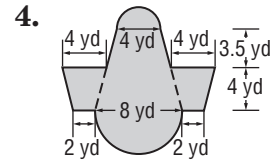
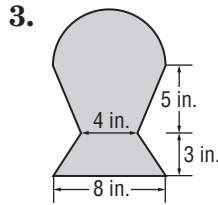
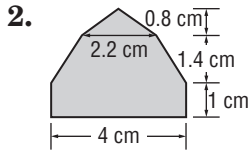
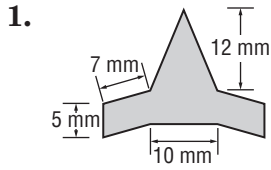

9. What is the area of a figure formed using a square with sides of 15 centimeters and four attached semicircles?

10. Find the area of a figure formed using a parallelogram with a base of 10 yards and a height of 12 yards and two triangles with bases of 10 yards and heights of 5 yards.

Find the area of each shaded area. Round to the nearest tenth, if necessary. (Hint: Find the total area and subtract the non-shaded area.)

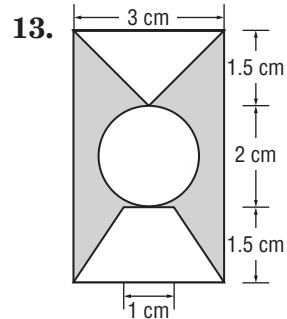
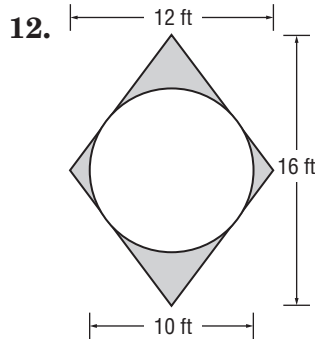
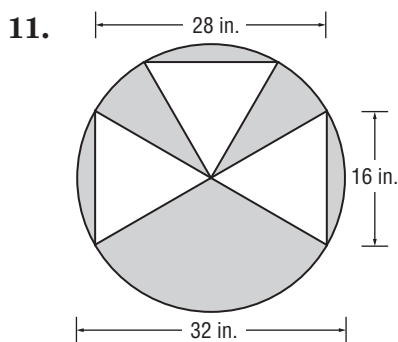

14. **HISTORY** What is the area of the track in the Circus Maximus as represented below? The center barrier was named the *spina*.

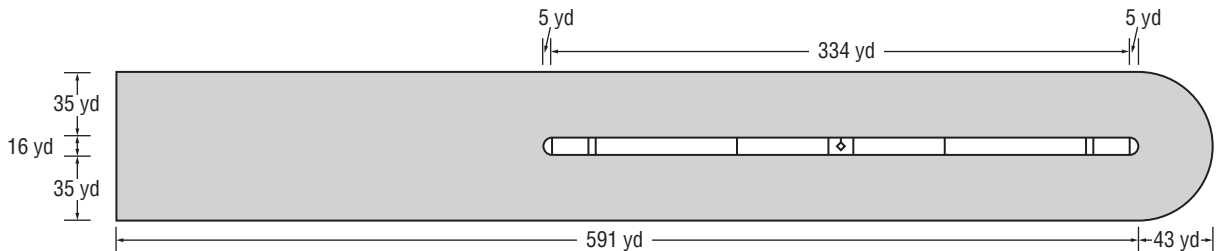

# 11-1 Practice

## Three-Dimensional Figures

Identify each solid. Name the bases, faces, edges, and vertices.

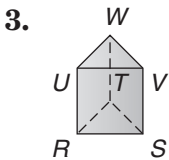
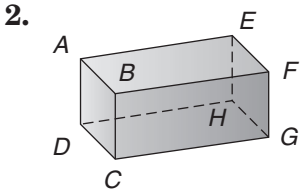
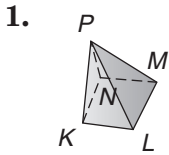

For Exercises 4–7, use the rectangular prism below.

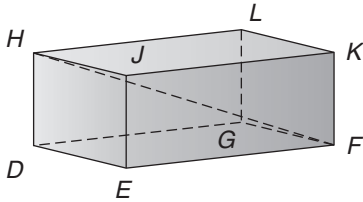

4. Identify a diagonal.
5. Name four segments skew to  $\overline{JK}$ .
6. State whether  $\overline{HJ}$  and  $\overline{FG}$  are *parallel*, *skew*, or *intersecting*.
7. Name a segment that does *not* intersect plane  $DGLH$ .
8. **ARCHITECTURE** A sketch shows the plans for a new observation tower at an amusement park. Each unit on the drawing represents 10 feet.

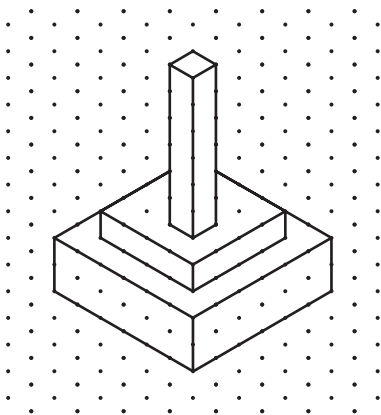

- a. Draw a top view and find the area of the bottom section.
- b. At the center of the tower, there is a staircase landing every 15 feet. How many landings are in the tower?

**11-2 Practice*****Volume: Prisms and Cylinders***

Find the volume of each solid shown or described. If necessary, round to the nearest tenth.

1.

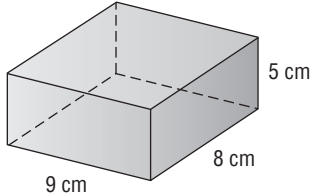

2.

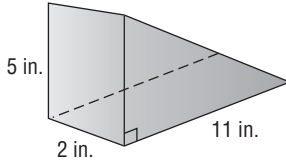

3.

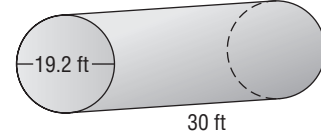

4.

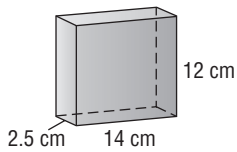

5.

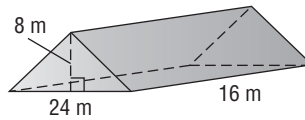

6.

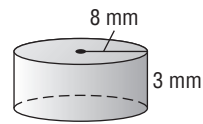

7.

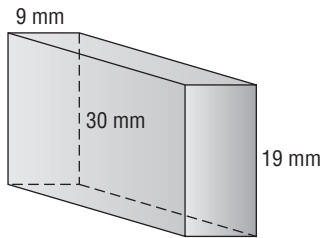

8.

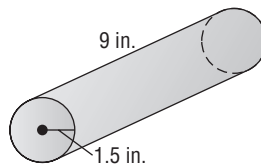

9.

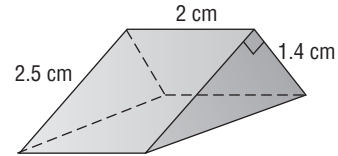

10. rectangular prism: length 22.5 ft, width 12.5 ft, height 1.2 ft
11. triangular prism: base of triangle 17 cm, altitude of triangle 3 cm, height of prism 10.2 cm
12. Find the height of a rectangular prism with a length of 11 meters, a width of 0.5 meter, and a volume of  $23.1 \text{ m}^3$ .
13. Find the height of a cylinder with a radius of 8.4 inches and a volume of  $3546.7 \text{ in}^3$ . Round to the nearest tenth.
14. A cube is 8 inches on each side. What is the height of a cylinder having the same volume, if its radius is 4 inches? Round to the nearest tenth.

# 11-3 Practice

## Volume: Pyramids, Cones, and Spheres

Find the volume of each solid. If necessary, round to the nearest tenth.

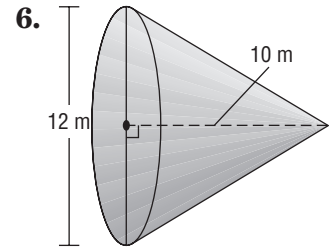
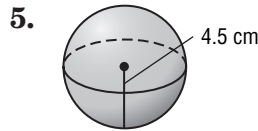
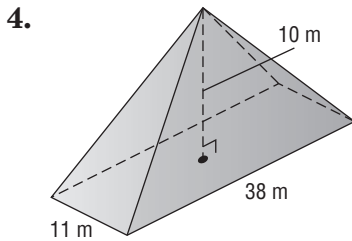
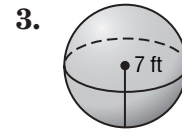
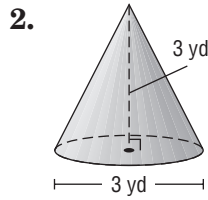
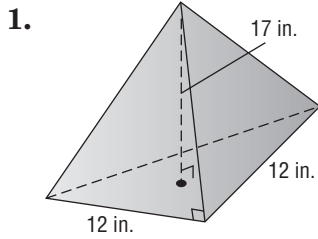

7. Find the volume of a rectangular pyramid with a length of 14 feet, a width of 12 feet, and a height of 9 feet.
8. Find the radius of a sphere with a volume of  $972\pi \text{ cm}^3$ .
9. Find the height of a cone with a radius of 12 in. and a volume of  $408\pi \text{ in}^3$ .
10. **CONTAINERS** A cone with a diameter of 3 inches has a height of 4 inches. A 2-inch square pyramid is being designed to hold nearly the same amount of ice cream. What will be the height of the square pyramid? Round to the nearest tenth.

# 11-4 Practice

## Surface Area: Prisms and Cylinders

Find the lateral area and surface area of each solid shown or described. If necessary, round to the nearest tenth.

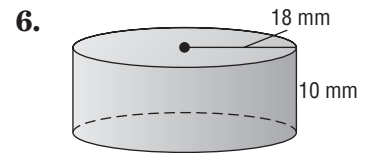
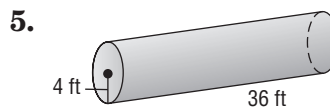
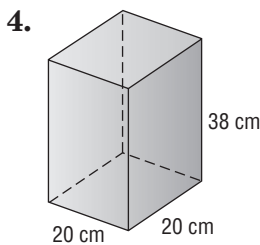
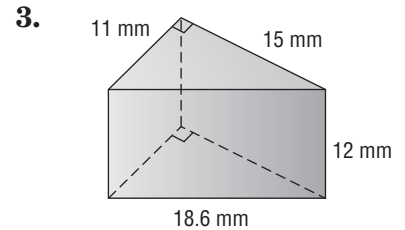
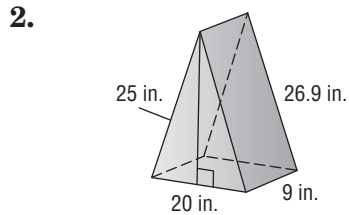
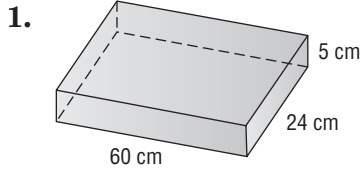

7. rectangular prism: length 10.2 m, width 8.5 m, height 9.1 m

8. rectangular prism: length 15.4 cm, width 14.9 cm, height 0.8 cm

9. cylinder: radius 28 mm, height 32 mm

10. cylinder: diameter 1.6 ft, height 4.2 ft

11. **DECORATING** A door that is 30 inches wide, 84 inches high, and 1.5 inches thick is to be decoratively wrapped in gift paper. How many square inches of gift paper are needed?

**PACKAGING** For Exercises 12 and 13, use the following information. A cardboard shipping container is in the form of a cylinder, with a radius of 6 centimeters and a volume of 8595.4 cubic centimeters.

12. Find the length of the shipping container. Round to the nearest tenth.

13. Find the surface area of the shipping container. Round to the nearest tenth.

# 11-5 Practice

## Surface Area: Pyramids and Cones

Find the surface area of each solid. If necessary, round to the nearest tenth.

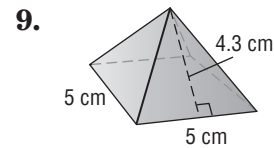
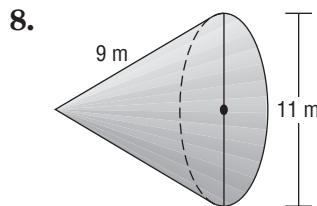
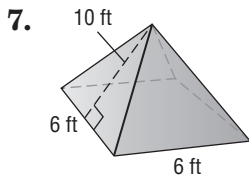
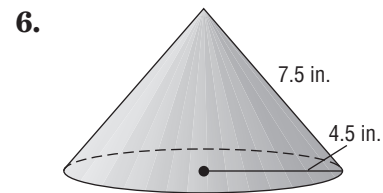
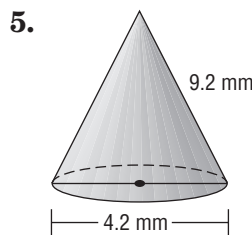
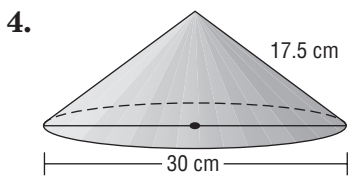
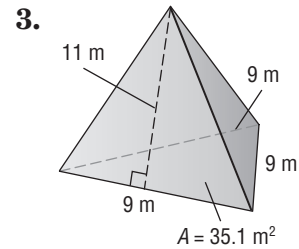
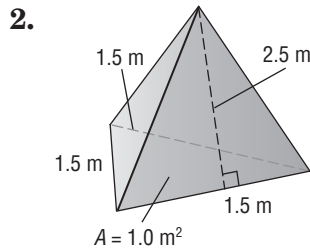
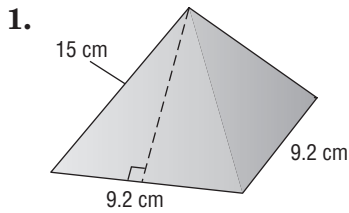

10. square pyramid: base side length 8.4 in., slant height 8.4 in.
11. cone: radius 9 ft, slant height 22 ft
12. cone: diameter 26 cm, slant height 15 cm
13. **PAINTING** A wooden structure at a miniature golf course is a square pyramid whose base is 5 feet on each side. The slant height is 4.75 feet. Find the lateral area to be painted.
14. **BAKING** A cone-shaped icicle on a gingerbread house will be dipped in frosting. The icicle is 1 centimeter in diameter and the slant height is 7 centimeters. What is its total surface area?
15. **HISTORY** The Great Pyramid in Egypt was built for the Pharaoh Khufu. The base of each side is 230 meters. The height from the base along the face to the top is 187 meters. Find the total surface area.



# 11-6 Practice

## Similar Solids

Determine whether each pair of solids is similar.

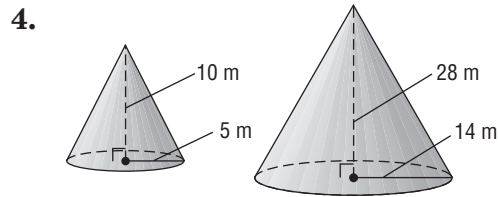
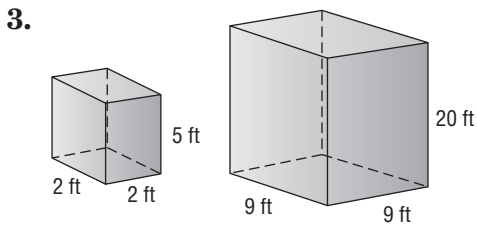
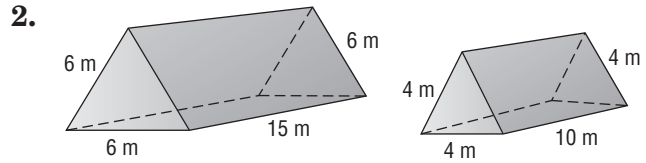
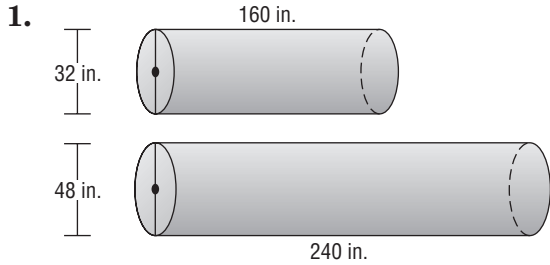

Find the missing measure for each pair of similar solids.

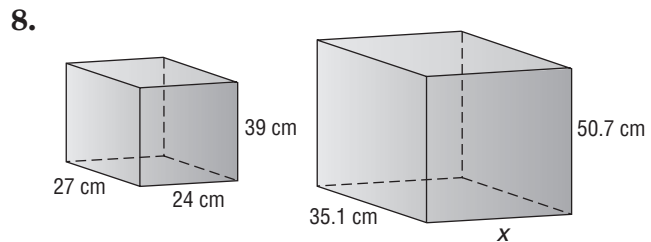
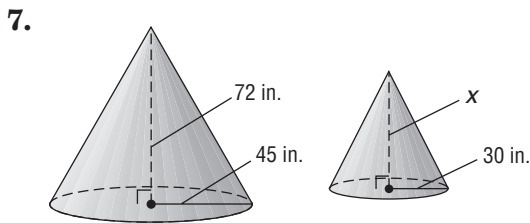
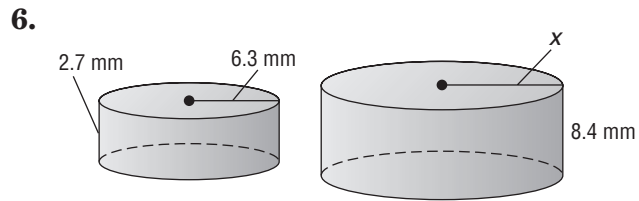
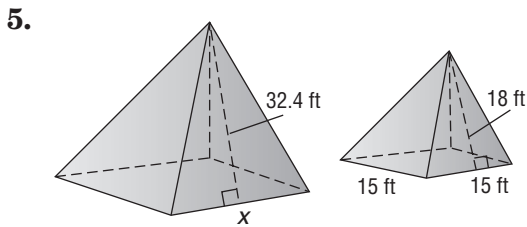

**PLAYGROUNDS** For Exercises 9 and 10, use the following information.

In the miniature village at the playground, the model of the old school building is 6.6 feet long, 3.3 feet wide, and 4.6 feet high.

9. If the real building was 80 feet long and 40 feet wide, how high was it?

10. What was the volume of the old school building in cubic feet?

# 12-1 Practice

## Stem-and-Leaf Plots

Display each set of data in a stem-and-leaf plot.

- {68, 63, 70, 59, 78, 64, 68, 73, 61, 66, 70}
- {27, 32, 42, 31, 36, 37, 47, 23, 39, 31, 41, 38, 30, 34, 29, 42, 37}

3.

Major League Baseball Leading Pitchers, 2005	
Player and Team	Wins
C. Capuano	18
C. Carpenter	21
B. Colon	21
J. Garland	18
R. Johnson	17
C. Lee	18
J. Lieber	17
R. Oswalt	20
A. Pettitte	17
D. Willis	22

Source: sports.espn.go.com

4.

Average Prices Received by U.S. Farmers, 2004	
Commodity	Price (dollars per 100 pounds)
Beef Cattle	86
Hogs	49
Lambs	101
Milk	16
Veal Calves	119

Source: U. S Department of Agriculture

**RECREATION** For Exercises 5–7, use the information in the back-to-back stem-and-leaf plot shown at the right.

- The category with the lowest total expenditure in 1992 was motion pictures. What was its total?
- What is the median total recreational spending for 1992? For 2002?
- Compare the total spending on recreation in 1992 with that in 2002.

Total U.S. Spending on Personal Recreation (by Category)

1992	2002
7 5 5	0 9
8 7 2 0	1 0 2 8
7 2	2 2
4 0	3 4 5 7
	4 4
	5 6
1	6 0
	7
	8 4
	9

7 | 2 = \$27 billion

3 | 5 = \$35 billion

# 12-2 Practice

## Measures of Variation

Find the range, interquartile range, and any outliers for each set of data.

1. {3, 9, 11, 8, 6, 12, 5, 4}
2. {8, 3, 9, 14, 12, 11, 20, 23, 5, 26}
3. {42, 50, 46, 47, 38, 41}
4. {10.3, 9.8, 10.1, 16.2, 18.0, 11.4, 16.0, 15.8}
5. {107, 82, 93, 112, 120, 95, 98, 56, 109, 110}
6. {106, 103, 112, 109, 115, 118, 113, 108}

7. Stem | Leaf

1	7 8
2	2 3 5 6 8
3	0

2 | 2 = 22

8. Stem | Leaf

5	6 7
6	0 1 1 4 8 8 9
7	0 2 3 5 6 7

6 | 1 = 61

9. Stem | Leaf

4	0 0 0 2 5 7
5	2 6
6	1 8 8
7	0 1 9

5 | 2 = 52

10. Stem | Leaf

6	4 7 9
7	9
8	1 1 3 3 4 6
9	0 1 2 5

7 | 9 = 79

11. Stem | Leaf

3	0 1 6 8
4	4
5	2
6	
7	3 3
8	9

5 | 2 = 52

12. Stem | Leaf

4	3 3 5 7 9
5	0 0 1
6	2
7	4 4 6 8
8	
9	0 1 1 2 2 5

5 | 1 = 51

**POPULATION** For Exercises 13–15, use the data in the table at the right.

13. What is the range of populations shown?
14. What is the interquartile range for the annual growth rate?
15. Where does the city with the fastest growth rate fall in terms of population? The city with the slowest growth rate?

Populations of the World's Largest Cities 2000		
City	Population (millions)	Annual Growth Rate (%)
Tokyo, Japan	26.4	0.51
Mexico City, Mexico	18.1	1.81
Mumbai, India	18.1	3.54
Sao Paulo, Brazil	17.8	1.43
New York City, U.S.	16.6	0.37
Lagos, Nigeria	13.4	5.33
Los Angeles, U.S.	13.1	1.15
Calcutta, India	12.9	1.60
Shanghai, China	12.9	-0.35
Buenos Aires, Argentina	12.6	1.14

Source: World Almanac

# 12-3 Practice

## Box-and-Whisker Plots

Draw a box-and-whisker plot for each set of data.

- {14, 30, 35, 8, 29, 28, 31, 42, 20, 36, 32}
- {\$105, \$98, \$83, \$127, \$115, \$114, \$132, \$93, \$107, \$101, \$119}
- {211, 229, 196, 230, 240, 212, 231, 233, 243, 214, 239, 238, 228, 237, 230, 234, 239, 240, 212, 232, 239, 240, 237}
- {3.7, 6.2, 4.1, 2.4, 1.0, 1.5, 1.4, 2.1, 2.6, 3.0, 1.3, 1.7}

For Exercises 5–7, use the box-and-whisker plot shown.

- How tall is the highest peak of the Hindu Kush?
- What is the median height of the major peaks?
- Write a sentence describing what the box-and-whisker plot tells about the major peaks of the Hindu Kush.

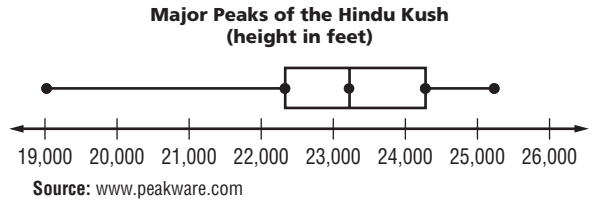

For Exercises 8–10, use the box-and-whisker plot shown.

- In which year was the corn yield more varied? Explain.
- How does the median yield in 2003 compare with the median yield in 1999?

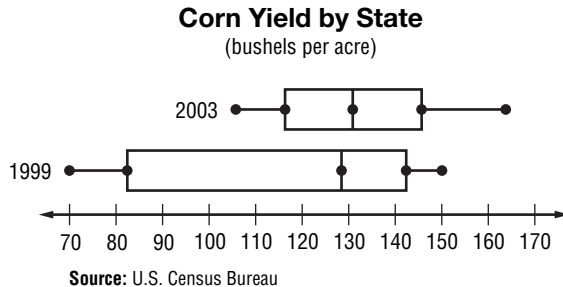

- Write a few sentences that compare the 1999 yields with the 2003 yields.

# 12-4 Practice

## Histograms

Display each set of data in a histogram.

1.

Ages of Zoo Volunteers		
Age	Tally	Frequency
18–27		3
28–37		8
38–47		16
48–57		12
58–67		5
68–77		2

2.

Crossword Puzzle Solving Times		
Time (min)	Tally	Frequency
0–4		3
5–9		1
10–14		6
15–19		14
20–24		0
25–29		2

For Exercises 3–6, use the histogram at the right.

- What size are the intervals?
- How many countries have nine or fewer threatened species?
- Which interval contains the median number of endangered species?
- Can you tell from the histogram whether any of the countries have zero threatened species? Explain.

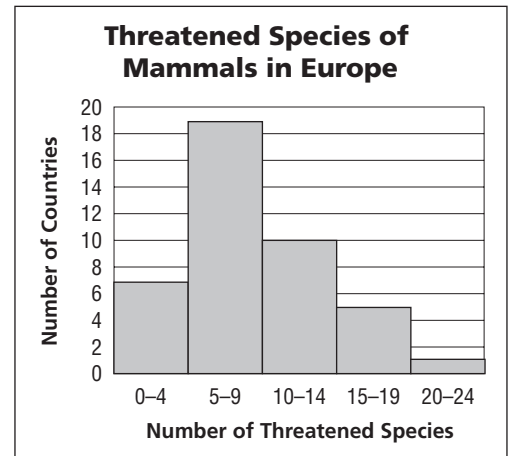

Source: www.redlist.org

**12-5 Practice*****Choosing an Appropriate Display***

**Choose an appropriate style of display for each data set. Justify your choice.**

1. the monthly price of apples over a two year period.
2. results of a poll of 30 students favorite type of candy
3. the income of the middle 50% of U.S. households
4. the number of terms served by current senators
5. the number of runners who finished a marathon in each ten-minute interval

**Choose an appropriate style of display for each data set. Then make a display.**

6. Winning times for the 200-Meter backstroke event at the Olympics.

Year	Winning Time
1976	1:59.19
1980	2:01.93
1984	2:00.23
1988	1:59.37
1992	1:58.47
1996	1:58.54
2000	1:56.76
2004	1:54.95

Source: *World Almanac*

7. 

Monthly Park Visitors (in thousands)		
6	7	12
15	25	40
46	46	37
22	19	8

# 12-6 Practice

## Misleading Graphs

For Exercises 1–3, refer to the graphs below.

**U.S. Consumption of Hydroelectric Power, 1960–2002 Graph A**

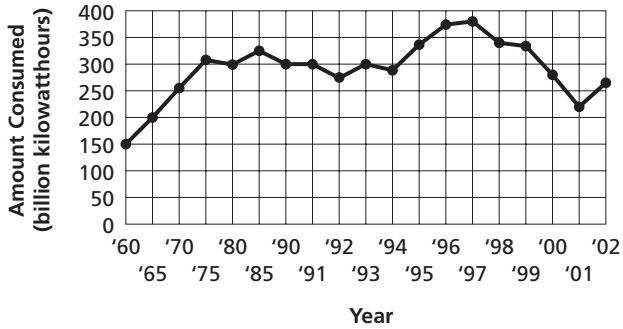

**U.S. Consumption of Hydroelectric Power, 1960–2002 Graph B**

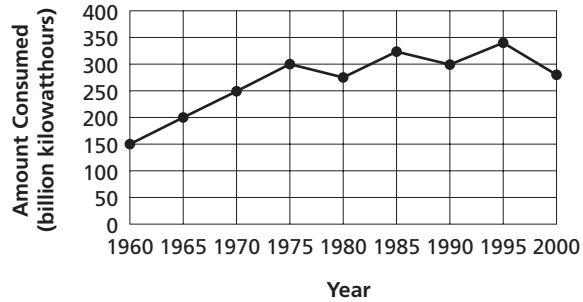

1. What was the U.S. consumption of hydroelectric power in 1990?
2. Which graph gives the impression that the use of hydroelectric power in the United States has experienced many dips as well as rises between 1975 and 2002?
3. What causes the graphs to differ in their appearance?

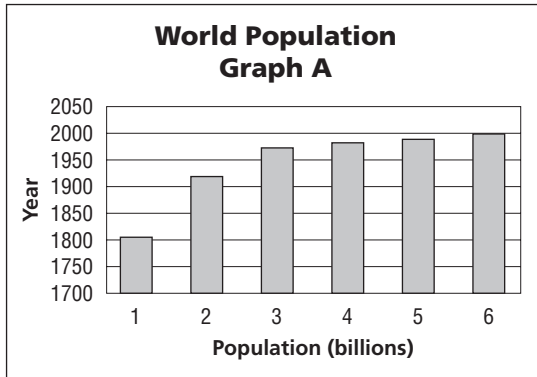

Source: www.pbs.org

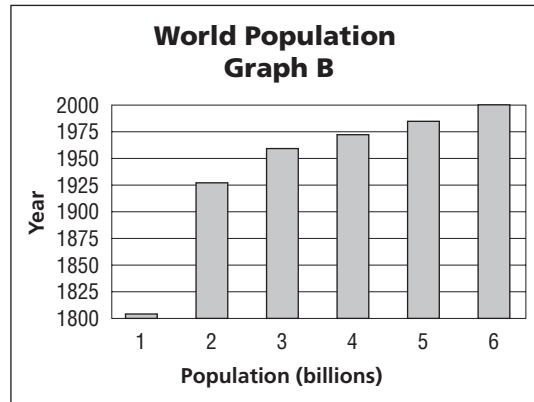

Source: www.pbs.org

For Exercises 4–6, refer to the graphs below.

4. What was the world's population in 1999?
5. Which graph gives the impression that the world's population skyrocketed between 1800 and 1925? Explain.
6. Are the vertical axis and the horizontal axis in either graph misleading? Explain.

# 12-7 Practice

## Simple Probability

A spinner like the one shown is used in a game. Determine the probability of each outcome if the spinner is equally likely to land on each section. Express each probability as a fraction and as a percent.

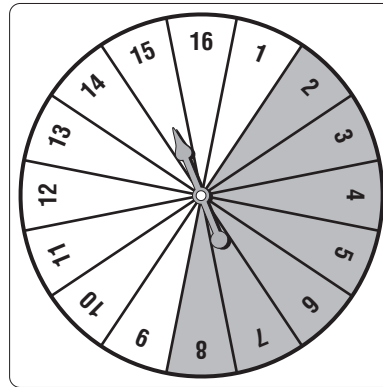

- |                                 |                               |                         |
|---------------------------------|-------------------------------|-------------------------|
| 1. $P(15)$                      | 2. $P(\text{even})$           |                         |
| 3. $P(\text{greater than } 10)$ | 4. $P(\text{perfect square})$ | 5. $P(1 \text{ or } 2)$ |
| 6. $P(\text{less than } 9)$     | 7. $P(\text{not shaded})$     | 8. $P(\text{shaded})$   |

There are 8 red marbles, 5 blue marbles, 11 green marbles, and 1 yellow marble in a bag. Suppose one marble is selected at random. Find the probability of each outcome. Express each probability as a fraction and as a percent.

- |                             |                       |                                     |
|-----------------------------|-----------------------|-------------------------------------|
| 9. $P(\text{red})$          | 10. $P(\text{blue})$  | 11. $P(\text{yellow})$              |
| 12. $P(\text{red or blue})$ | 13. $P(\text{black})$ | 14. $P(\text{red, blue, or green})$ |

Suppose two 1–6 number cubes are rolled. Find the probability of each outcome. Express each probability as a fraction and as a percent. (*Hint: Make a table to show the sample space as in Example 2.*) Round to the nearest tenth if necessary.

- |                                  |                                |                                 |
|----------------------------------|--------------------------------|---------------------------------|
| 15. $P(1 \text{ or } 5)$         | 16. $P(\text{both odd})$       | 17. $P(\text{even product})$    |
| 18. $P(\text{sum more than } 8)$ | 19. $P(\text{both different})$ | 20. $P(\text{sum is a square})$ |

21. To the nearest tenth of a percent, what is the probability that today is a weekday?



**12-8 Practice****Counting Outcomes**

**Find the number of possible outcomes for each situation.**

- Joan randomly dials a seven-digit phone number.
- First-year students at a school must choose one each of 5 English classes, 4 history classes, 5 math classes, and 3 physical education classes.
- One card each is drawn from four different standard decks of cards.
- A store offers running shoes with either extra stability or extra cushioning from four different manufacturers.
- A winter sweater comes in wool or fleece, with a zipper or a crew neck, and in three colors.
- One spinner can land on red, green, blue, or yellow and another can land on right foot, left foot, right hand, or left hand. Each spinner is spun once.

**Find the probability of each event.**

- A number cube is rolled. What is the probability of rolling a 4 or lower?
- A number cube is rolled. What is the probability of getting a five or higher?
- An eight-sided die is rolled and a coin is tossed. What is the probability of landing on an even number and getting heads?
- A coin is tossed and a card is drawn from a standard deck of cards. What is the probability of landing on heads and choosing a heart?
- REFRESHMENTS** How many fruit smoothies are possible from 6 choices of fruit, 4 choices of milk, and 3 sizes?
- MONOGRAMS** A school's class rings can include a student's initials in an engraved monogram on the ring. How many different monograms are possible from 2 sizes, 5 type styles, and 3 border styles?
- MOBILE PHONES** The table shows the features you can choose for a pay-as-you go phone plan.
  - How many phone plans have national long distance?
  - How many customized phone plans include 100 minutes per month talkingtime and paging capabilities?

Phone	Features	Calling Area	Monthly Talk Time
Brand A; Brand B	e-mail only; paging only; deluxe: paging and e-mail	local only; local and regional; national long distance	30 min; 60 min; 100 min

**12-9 Practice*****Permutations and Combinations***

Tell whether each situation is a *permutation* or *combination*. Then solve.

1. How many ways can you make a sandwich by choosing 4 of 10 ingredients?
2. How many ways can 11 photographs be arranged horizontally?
3. How many ways can you buy 2 software titles from a choice of 12?
4. How many ways can a baseball manager make a 9-player batting order from a group of 16 players?
5. How many ways can 30 students be arranged in a 4-student line?
6. How many ways can 3 cookie batches be chosen out of 6 prize-winning batches?
7. **SCHOOL TRIPS** Students are chosen in groups of 6 to tour a local business. How many ways can 6 students be selected from 3 classes totaling 53 students?
8. **CONTESTS** In a raffle, 5 winners get to choose from 5 prizes, starting with the first name drawn. If 87 people entered the raffle, how many ways can the winners be arranged?
9. **RESTAURANTS** A local restaurant specializes in simple and tasty meals.
  - a. How many sandwiches are possible if the restaurant lets you build a sandwich by choosing any 4 of 10 sandwich ingredients?
  - b. If there are 6 soups to choose from, how many soup-and-build-a-sandwich specials are possible?
10. **SPORTS** An inline skate has 4 wheels. How many ways could 4 replacement wheels be chosen from a pack of 10 wheels and fitted to a skate?

**GIFT WRAPPING** For Exercises 11–14, use the following information.

**An upscale department offers its customers free gift wrapping on any day that they spend at least \$100. The store offers 5 box sizes (XS, S, M, L, XL), 6 wrapping themes (birthday, wedding, baby girl, baby boy, anniversary, and all-occasion), and 3 styles of bow (classic, modern, and jazzy).**

11. How many ways can packages be gift-wrapped at the store?
12. What is the probability that any wrapped package will be in a large box?
13. What is the probability that any wrapped package will *not* have a jazzy bow?
14. What is the probability that a customer will request wrapping for a baby-boy gift?

# 12-10 Practice

## Probability of Composite Events

An eight-sided die is rolled and the spinner is spun. Find each probability.

- $P(4 \text{ and yellow fruit or vegetable})$
- $P(\text{an odd number and a pumpkin})$
- $P(\text{a prime number and a red fruit or vegetable})$
- $P(\text{a number less than 4 and a blue fruit or vegetable})$

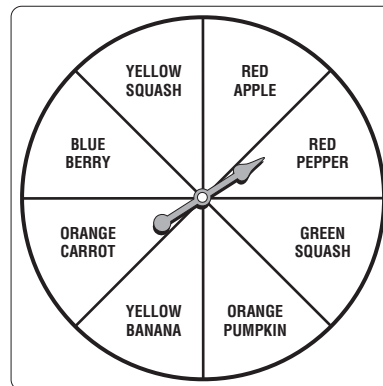

There are 6 orange marbles, 2 red marbles, 3 white marbles, and 4 green marbles in a bag. Once a marble is drawn, it is replaced. Find the probability of each outcome.

- a red then a white marble
- a white then a green marble
- two orange marbles in a row
- two marbles in a row that are *not* white
- a green then a *not* green marble
- a red then an orange then a green marble

There are 2 green marbles, 7 blue marbles, 3 white marbles, and 4 purple marbles in a bag. Once a marble is drawn, it is *not* replaced. Find the probability of each outcome.

- a green then a white marble
- a blue then a purple marble
- two blue marbles in a row
- two marbles in a row that are *not* purple
- a white then a purple marble
- three purple marbles in a row

The chart shows the letter-number combinations for bingo. The balls are randomly drawn one at a time. Balls are *not* replaced after they are drawn. Find the probability of each outcome.

- a B-1
- a G
- an N or a B-2
- an I or an O
- not* a G
- a B-6, then a G, then another G

B	I	N	G	O
1	13	25	37	49
2	14	26	38	50
3	15	27	39	51
4	16	28	40	52
5	17	29	41	53
6	18	30	42	54
7	19	31	43	55
8	20	32	44	56
9	21	33	45	57
10	22	34	46	58
11	23	35	47	59
12	24	36	48	60

**13-1 Practice*****Polynomials***

Determine whether each expression is a polynomial. If it is, classify it as a *monomial*, *binomial*, or *trinomial*.

1.  $-3n^2$

2.  $v^2 - 9v$

3.  $g + 2h + jk$

4.  $6b + 2 + \frac{8}{b}$

5.  $m + 10$

6.  $a^2b^2 + 9$

7.  $1 + \sqrt{s}$

8.  $q$

9.  $h + h^2 + 1$

10.  $m + n - p$

11.  $y^4 + 5y - 2$

12.  $x - \sqrt{x}$

13.  $-5w^7t$

14.  $41 - qr^4$

15.  $p^4 + p^2 + p$

16.  $\frac{2x^2}{7} + \frac{5x}{7} + \frac{3}{7}$

17.  $\frac{v}{5} + \frac{1}{2}$

18.  $10k - \sqrt{6}$

19. 4

20.  $\frac{3}{c^2} - \frac{5}{c} - \frac{1}{2}$

21.  $7g^2h^7$

Find the degree of each polynomial.

22.  $-52$

23.  $xy$

24.  $c$

25.  $2c^5 - c^3 - c - 9$

26.  $ab^3$

27.  $2xy^4z^3 + 7$

28.  $r - 25$

29.  $\frac{-4}{9}$

30. 12.4

31.  $12 + 9t - t^2$

32.  $5a^3 - a + 8$

33.  $1 - c^2 + c^4$

34.  $xy^2 - 3x^2y + xy$

35.  $b^5 + b - 1.5$

36.  $15k + 2$

37.  $cde^8 + c^4 + 2e$

38.  $wxyz - 2wx - 5y - yz + 4$

39.  $-6g^2h^8 + gh^5 + 3$

40. **METEOROLOGY** *Summer simmer index* measures the discomfort level due to temperature and humidity. Meteorologists calculate this value by using a polynomial similar to  $1.98x^2 - 115.93x + 0.01xy - 0.63y + 6.33$ . The variable  $x$  is the temperature in °F and  $y$  is the relative humidity expressed as a whole number. What is the degree of the polynomial?

**13-2 Practice****Adding Polynomials**

Find each sum.

$$\begin{array}{r} 1. \quad 8q + 3 \\ (+) 4q - 2 \\ \hline \end{array}$$

$$\begin{array}{r} 2. \quad 9f - 3 \\ (+) -f - 15 \\ \hline \end{array}$$

$$\begin{array}{r} 3. \quad 4r^2 + 11r \\ (+) 5r^2 - 3r - 7 \\ \hline \end{array}$$

$$\begin{array}{r} 4. \quad n^2 - 3n \\ (+) \quad 3n - 10 \\ \hline \end{array}$$

$$\begin{array}{r} 5. \quad 6w^2 + 2w + 7 \\ (+) 8w^2 + 3w - 9 \\ \hline \end{array}$$

$$\begin{array}{r} 6. \quad 8c^2 - 3c + 15 \\ (+) 3c^2 + 3c - 11 \\ \hline \end{array}$$

$$\begin{array}{r} 7. \quad -5p^2 - 2p + 4 \\ (+) 5p^2 + 2p - 4 \\ \hline \end{array}$$

$$\begin{array}{r} 8. \quad 7v^2 - 2v \\ (+) 7v^2 - v + 5 \\ \hline \end{array}$$

$$\begin{array}{r} 9. \quad 5m^2 + 6m - 3 \\ (+) 8m^2 + 9m - 2 \\ \hline \end{array}$$

$$\begin{array}{r} 10. \quad 7d^2 + 8d - 3 \\ (+) d^2 + d + 3 \\ \hline \end{array}$$

$$11. (r^2 + 9) + (-4r^2 + 6r + 10)$$

$$12. (g^2 + 3g - 6) + (6g^2 - 6g + 1)$$

$$13. (-2m + 10) + (5m - 3)$$

$$14. (4x^2 - 7x) + (8x + 5)$$

$$15. (3k^2 + 9k) + (k^2 - 2k - 4)$$

$$16. (2a^2 - 3ab) + (4ab - 8b^2)$$

$$17. (c + 4) + (c^2 - c + 6)$$

$$18. (5x^2 - 3xy) + (2xy + 9y^2)$$

$$19. (2y^3 + y^2 + 5) + (2y^2 + 3y)$$

$$20. (-5p^2 + 6p - 7) + (p^2 - 2)$$

$$21. (3ab^2 - 2a - 1) + (a^2 + ab + 3)$$

$$22. (6rs^3 + 4r) + (5rs^3 + 7)$$

**23. GEOMETRY** The lengths of the sides of a triangle are  $(x^2 - 5)$ ,  $(7x - 1)$ , and  $x$ . Find the perimeter of the triangle.

**13-3 Practice****Subtracting Polynomials**

Find each difference.

1. 
$$\begin{array}{r} 4y + 1 \\ (-) 3y + 8 \\ \hline \end{array}$$

2. 
$$\begin{array}{r} 2k + 3 \\ (-) 7k - 6 \\ \hline \end{array}$$

3. 
$$\begin{array}{r} 5j^2 + 2j - 2 \\ (-) j^2 + 9j + 2 \\ \hline \end{array}$$

4. 
$$\begin{array}{r} c^2 + 5c - 3 \\ (-) -c^2 - 5c - 1 \\ \hline \end{array}$$

5. 
$$\begin{array}{r} d^2 - 4d + 6 \\ (-) d^2 + 3d - 8 \\ \hline \end{array}$$

6. 
$$\begin{array}{r} 2n^2 - 3n - 10 \\ (-) -n^2 - 3n + 8 \\ \hline \end{array}$$

7. 
$$\begin{array}{r} 9m^2 - 4m + 13 \\ (-) 7m^2 - 2m - 3 \\ \hline \end{array}$$

8. 
$$\begin{array}{r} d^2 + 3d - 6 \\ (-) d^2 + 3d + 6 \\ \hline \end{array}$$

9. 
$$\begin{array}{r} -6q^2 - 3q + 2 \\ (-) 3q^2 + 4q + 4 \\ \hline \end{array}$$

10. 
$$\begin{array}{r} v^2 - v \\ (-) 2v^2 - 9v - 3 \\ \hline \end{array}$$

11.  $(4n^2 - n - 6) - (-2n^2 - 3n - 14)$

12.  $(3k^2 + 9k) - (8k^2 - 12)$

13.  $(k^2 - 7) - (k - 11)$

14.  $(9x^2 - x - 2) - (3x^2 - x - 4)$

15.  $(k^2 - 12) - (k^2 + 6k - 9)$

16.  $(k^2 + 4kb) - (5kb + 2b^2)$

17.  $(3u^2 - 9) - (u^2 + 21u + 2)$

18.  $(5m^2 - 4mn) - (4mn + 8n^2)$

19.  $(h^2 + 8h + 5) - (h^2 - 3h - 7)$

20.  $(2x^2 - 4x - 8) - (2x - 8x^2)$

21.  $(6g^2 + 3g + 2) - (g^2 + g - 4)$

22.  $(b^3 + b^2 - ab) - (b^3 + 3b^2 + 5)$

**23. POOLS** A swimming pool is  $(4w^2 - 16)$  feet long and  $(w - 16)$  feet wide. How much longer is the length than the width?

**13-4 Practice*****Multiplying a Polynomial by a Monomial*****Find each product.**

1.  $5(3k + 8)$

2.  $(3h + 6)2$

3.  $-2(q - 4)$

4.  $(3v - 5)(-7)$

5.  $11(4d - 7)$

6.  $-8(12c - 6)$

7.  $(5g - 10)(-5)$

8.  $2(5p - 10)$

9.  $-9(3f^2 - 2f - 1)$

10.  $2.5(8w + 5)$

11.  $(4r^3 - 3r)(-8)$

12.  $-6(3x^2 - 2x + 7)$

13.  $n(7n + 3)$

14.  $(6u - 15)(-u)$

15.  $-h(8h + 2)$

16.  $(8y + 3)(-y)$

17.  $a(4a - 4)$

18.  $(5p + 15)(-p)$

19.  $-d(-5d + 1)$

20.  $-g(1.8g + 10)$

21.  $m(0.9m^2 - 0.5)$

22.  $(2q^3 - 5q^2 - 2q)(-q)$

23.  $k^3(7k^4 - 2k^2 + 6)$

24.  $ab(10a^2b + 3a)$

25.  $y^2(5x - 2xy + y)$

26.  $n(8 - m - 12mn^2)$

27.  $(4gh^2 - 2g^2 - h)(-g^2)$

28.  $(20q - 4)(-2q)$

29.  $14k(2k + 5)$

30.  $(9p - 7)(-3p^2)$

31.  $(0.2c - 1)(-1.5c^2)$

32.  $-6.5n(4n^2 - 8)$

33.  $-6x^2(4x^2 - 10x)$

34.  $5h^2(2h^3 - h^2 - 7h + 8)$

35.  $(4y^2 - 3y + 9)(-2y)$

36.  $6gh(8g^2 + 4gh + 3h^2)$

37.  $10a(2a^2 - 5ab + 4a)$

38.  $(8x^2 - 3xy - xy^2)(-7x)$

39.  $-5c^2(2cd - d^2 + 1)$

40. Find the area of a porch that is  $3x$  feet wide and  $4x + 9$  feet long.

# 13-5 Practice

## Linear and Nonlinear Functions

Determine whether each graph, equation, or table represents a *linear* or *nonlinear* function. Explain.

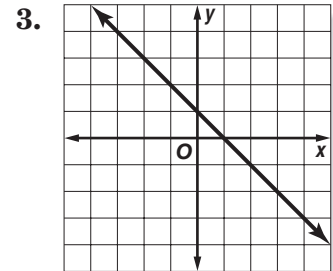
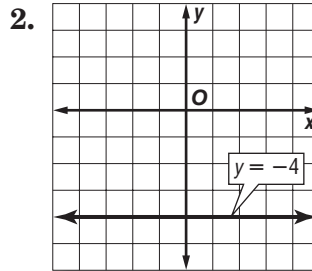
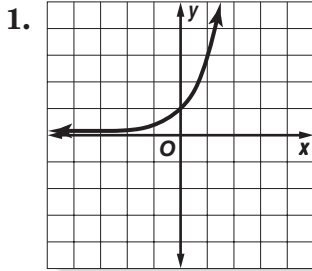

4.  $5x - y = 15$

5.  $3y + 12x^2 = 0$

6.  $5y - x + 3 = 0$

7.  $y = 6\sqrt{x} + 10$

8.  $y = \frac{8}{x}$

9.  $y = -x^2 + 2$

10.

x	y
1	1.0
2	0.8
3	0.6
4	0.4

11.

x	y
44	0
48	2.5
52	5.0
56	7.5

12.

x	y
3	1
6	-2
9	-5
12	-14

13. **GEOMETRY** The graph shows how the area of a square increases as the perimeter increases. Is this relationship linear or nonlinear? Explain.

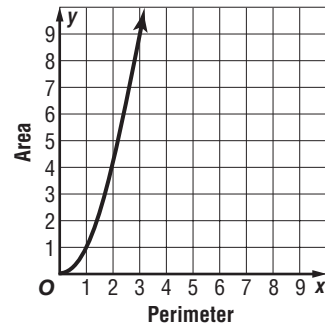



# 13-6 Practice

## Graphing Quadratic and Cubic Functions

Graph each function.

1.  $y = 0.4x^2$

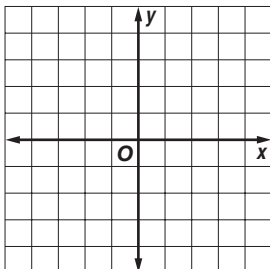

2.  $y = 0.4x^3$

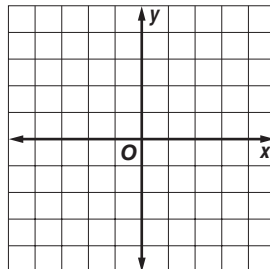

3.  $y = -2x^2 - 1$

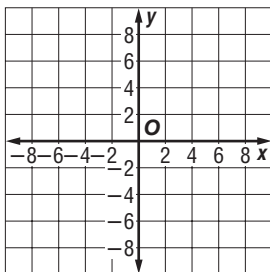

4.  $y = -2x^3 - 1$

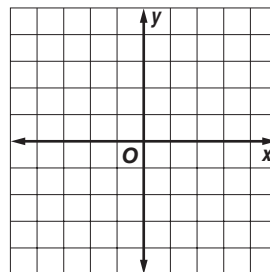

5. **WINDOWS** A window maker has 25 feet of wire to frame a window. One side of the window is  $x$  feet and the other side is  $9 - x$  feet.

a. Write an equation to represent the area  $A$  of the window.

b. Graph the equation you wrote in part a.

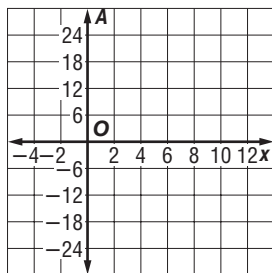

c. If the area of the window is 18 square feet, what are the two possible values of  $x$ ?

